

Ultra High Definition LED

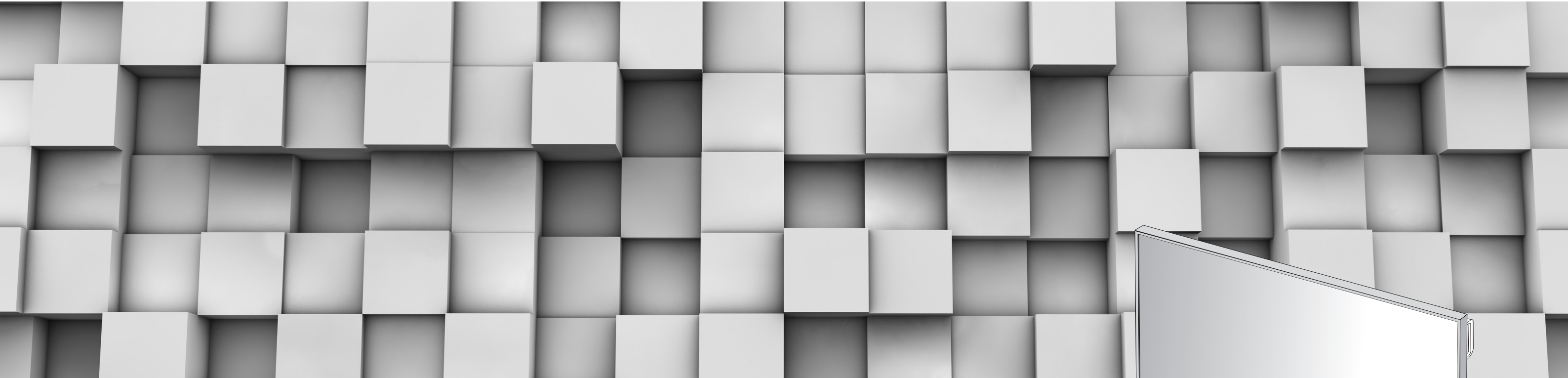

ORION CO.,LTD.
www.oriondisplay.net

Address: 257-6, Gongdan-dong, Gumi-si, Gyeongsangbuk-do, Korea
Tel : +82-2-6678-8533, Fax: +82-2-6678-8599



User's Manual

Thank you for purchasing this product.
Please read this manual thoroughly prior to install the product for your safety.

Features

- ▶ Enjoy a wide flat screen with high brightness and high quality.
- ▶ Easy to install and move due to its thin design
- ▶ Enjoy your favorite programs with various split-screen features simultaneously presenting several programs.

Thank you for purchasing this product.

This manual describes how to use the product and notes in use.
Please read the manual carefully before using it.
After reading this manual, please retain for future reference.
If you have any questions or a problem occurs, please contact either the company you purchased this product from or an authorized service center.

- ※ **Displaying static picture for an extended period of time may cause a burn-in effect.**
- ※ **Burn-in effect and the faults in brightness and picture elements caused by fixed images are not subject to the warranty coverage.**

 **Warning** If you fail to comply with the regulations for safety and proper use, fire or injury may be caused.

 **Warning** To prevent electric shock, Do not remove cover.
No user serviceable part inside
Refer servicing to qualified service personnel.

Supplied Accessories

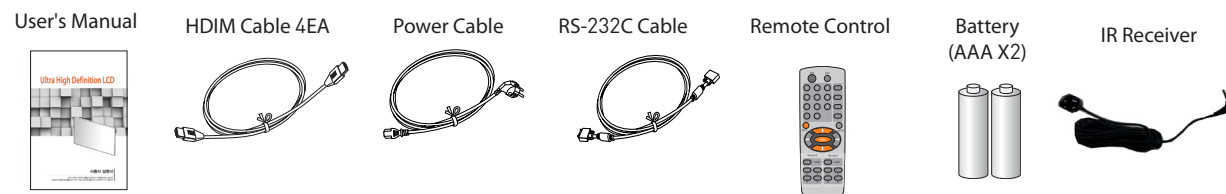

Options

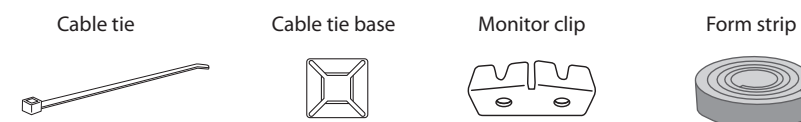



Notice to users

Class A digital device

It is a device designed for business purpose with a safety certificate for electromagnetic interference, which user should be mindful of.

" Important Safety Instructions"

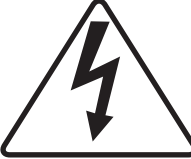
- 1) Read these instructions.
- 2) Keep these instructions.
- 3) Heed all warnings.
- 4) Follow all instructions.
- 5) Do not use this apparatus near water.
- 6) Clean only with dry cloth.
- 7) Do not block any ventilation openings. Install in accordance with the manufacturer's instructions.
- 8) Do not install near any heat sources such as radiators, heat registers, stoves, or other apparatus (including amplifiers) that produce heat.
- 9) Do not defeat the safety purpose of the polarized or grounding-type plug. A polarized plug has two blades with one wider than the other. A grounding type plug has two blades and a third grounding prong. The wide blade or the third prong are provided for your safety. If the provided plug does not fit into your outlet, consult an electrician for replacement of the obsolete outlet.
- 10) Protect the power cord from being walked on or pinched particularly at plugs, convenience receptacles, and the point where they exit from the apparatus.
- 11) Only use attachments/accessories specified by the manufacturer.
- 12) Use only with the cart, stand, tripod, bracket, or table specified by the manufacturer, or sold with the apparatus. When a cart is used, use caution when moving the cart/apparatus combination to avoid injury from tip-over. 
- 13) Unplug this apparatus during lightning storms or when unused for long periods of time.
- 14) Refer all servicing to qualified service personnel. Servicing is required when the apparatus has been damaged in any way, such as power-supply cord or plug is damaged, liquid has been spilled or objects have fallen into the apparatus, the apparatus has been exposed to rain or moisture, does not operate normally, or has been dropped.
The symbol in figure 21 shall be shown adjacent to the text of item 12 above.

	CAUTION RISK OF ELECTRIC SHOCK DO NOT OPEN	
CAUTION : TO REDUCE THE RISK OF ELECTRIC SHOCK, DO NOT REMOVE COVER (OR BACK). NO USER-SERVICEABLE PARTS INSIDE. REFER SERVICING TO QUALIFIED SERVICE PERSONNEL.		



This symbol is intended to alert the user to the presence of uninsulated "dangerous voltage" within the product's enclosure that may be of sufficient magnitude to constitute a risk of electric shock to persons.



This symbol is intended to alert the user to the presence of important operating and maintenance(servicing) instructions in the literature accompanying the appliance.

NOTICE

1. To disconnect the apparatus from the mains, the plug must be pulled out from the mains socket, therefore the mains plug shall be readily operable
2. WARNING - To Reduce The Risk Of Fire Or Electric Shock, Do Not Expose This Appliance To Rain Or Moisture.
3. Apparatus shall not be exposed to dripping or splashing and no objects filled with liquids, such as vases, shall be placed on the apparatus.
4. Use only a properly grounded plug and receptacle
5. "Warning" CAUTION – These servicing instructions are for use by qualified service personnel only. To reduce the risk of electric shock, do not perform any servicing other than that contained in the operating instructions unless you are qualified to do so.
6. "Warning" CAUTION – These servicing instructions are for use by qualified service personnel only. To reduce the risk of electric shock, do not perform any servicing other than that contained in the operating instructions unless you are qualified to do so.

Content

01. Cautions	4
▶ Cautions for System installation.....	4
▶ Application information.....	5
▶ Clearance for Ventilation.....	6
▶ Do not cover the vent hole for the fan.....	7
▶ Cleaning and Maintenance	7
02. Safety Precautions	8
03. Names	10
▶ Front	10
▶ Rear	10
▶ Input Ports.....	11
▶ KEY PAD	12
▶ Remote Controller	13
04. Cable Connection	14
05. How to use Remote Controller	16
06. Configuration	18
▶ BRIGHTNESS ADJUSTMENT	19
▶ CONTRAST ADJUSTMENT	19
▶ TINT ADJUSTMENT	20
▶ COLOR ADJUSTMENT	20
▶ VIDEO MODE SELECTION	21
▶ PICTURE RESET	22
▶ H POSITION	24
▶ V POSITION	24
▶ ASPECT RATIO Configuration.....	25
▶ VIDEO MUTE	26
▶ SCREEN RESET Adjustment.....	27
▶ AUTO POWER Configuration.....	29
▶ DISPLAY MODEL Configuration.....	29
▶ FIRMWARE Configuration.....	30
▶ LAN Configuration.....	30
▶ BAUD RATE Configuration	31
▶ OSD Configuration.....	32
▶ SETUP A RESET Configuration	36
▶ POWER ON SOURCE Configuration.....	38
▶ KEY LOCK Configuration.....	39
▶ SETUP B RESET Configuration	40
▶ FACTORY RESET Configuration	41
07. User guide for UHD Graphic	42
08. PROTOCOL	64
09. Before calling for service	80
10. Applicable signals	81
11. Specification	82
12. Dimension	84

01. Cautions

▶ Cautions for System installation

▶ Environmental condition for installation

- Since product panel is very sensitive for physical impact, installation requires considerable caution.
- Minimum clearance(20cm) must be secured for smooth ventilation. (See page 6p~7p 참조), nstallation must avoid air tight or near air tight places. Improper ventilation causes malfunction and shortens product lifetime by rapid internal temperature rise. If product has to installed at the improper ventilation, additional ventilation openings or fans must be provided to keep the internal temperature between 0 ~ 35°C.
- For ground of product and application devices, it should be connected as frame ground.
- Considering product Max power consumption, check the main electric specification.

▶ Recommended Operating Condition

- Temperature: 5~35°C, Humidity: 35~75%, Suitable operating time : under 12 hours a day.
- Do not install the set at the air-tight condition.
- It is recommended to install the set with good ventilation.
- Do not install the set at the place of direct sunlight or excessive exposure to lightings.
- ※ Blackening, stains or burning effect on the screen can be occurred by improper installation or use against the above recommended conditions.

▶ Consideration for easier service

- When you design the exterior design for product system, consider easier disassembly for possible service occasion in the future.
- The sliding Universal Unit of ORION is recommended for easier service.
- If service people can step into the backside of product system, it can greatly reduce time and effort for service.
- In case of higher locations, consider the installation location and exterior design for easier service.

▶ Application information

If static images are displayed on the screen for a long time, it causes burn-in image. Please keep the following instruction to optimize the lifetime and functions of the product.

1. Operating condition

- Temperature: 20 ± 15°C
- Humidity: 55 ± 20 %
- Display pattern: moving picture or regular switchover display
- Environmental condition : Well ventilated place is recommended.
- Power off and screen saver : Periodical power-off or screen saver is needed after long-term static display.

※ **Note : Moving picture or black pattern is strongly recommended for screen saver.**

2. Operating methods to minimize burn-in image due to long-term static information display

- Suitable operating time : under 12 hours a day.
- Periodical display contents change from static image to moving picture.
- Periodical background color and character (image) color change

DEPARTURE			DEPARTURE		
Flight No.	Time	Gate	Flight No.	Time	Gate
UA 012	11:20	A02	UA 012	11:20	A02
KE 732	12:10	K17	KE 732	12:10	K17
AN 291	12:45	F11	AN 291	12:45	F11

- Change the images of little luminance difference between the background and characters, periodically.

DEPARTURE			DEPARTURE			DEPARTURE			DEPARTURE		
Flight No.	Time	Gate	Flight No.	Time	Gate	Flight No.	Time	Gate	Flight No.	Time	Gate
UA 012	11:20	A02	UA 012	11:20	A02	UA 012	11:20	A02	UA 012	11:20	A02

- It is not recommended to display the images of huge luminance difference between the background and characters or the images of grey tone.

ARRIVAL				ARRIVAL			
Flight No.	Time	Gate	Delay	Flight No.	Time	Embark	Delay
AA 213	9:20	K11	On time	AA 213	9:20	New York	On time
OZ 621	11:25	G21	10 min.	OZ 621	11:25	Seoul	10 min.
JA 032	12:05	A19	On time	JA 032	12:05	Beijing	On time

- Scroll the characters periodically.

DEPARTURE			DEPARTURE			DEPARTURE		
Flight No.	Time	Gate	Flight No.	Time	Gate	Flight No.	Time	Gate
UA 012	11:20	A02	UA 012	11:20	A02	UA 012	11:20	A02
KE 732	12:10	K17	KE 732	12:10	K17	KE 732	12:10	K17
AN 291	12:45	F11	AN 291	12:45	F11	AN 291	12:45	F11

(Whole Screen Scroll)

► Clearance for Ventilation



-When you install product, make sure there is at least 20cm clearance for effective ventilation and do not seal off MLCD sets. If MLCD sets are installed at the locations of bad ventilation, the inner temperature can be raised rapidly and it can cause frequent malfunctions and rapid reduction of the product life.

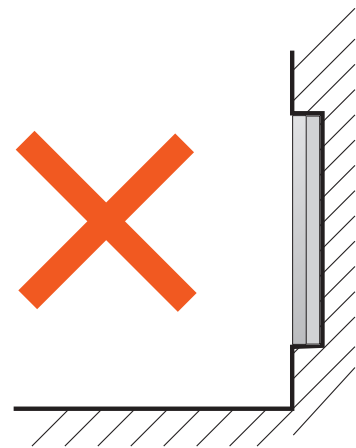
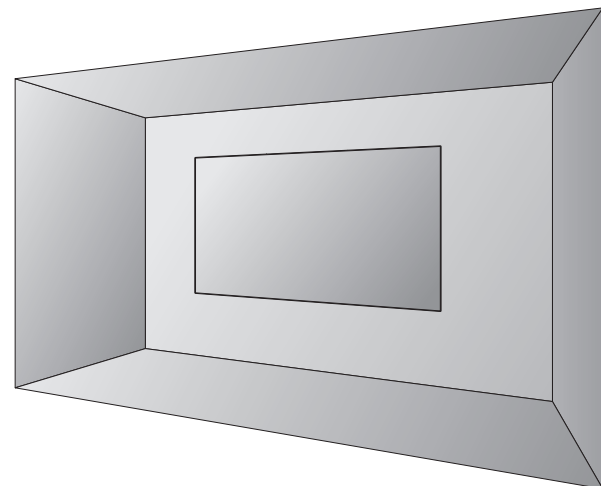
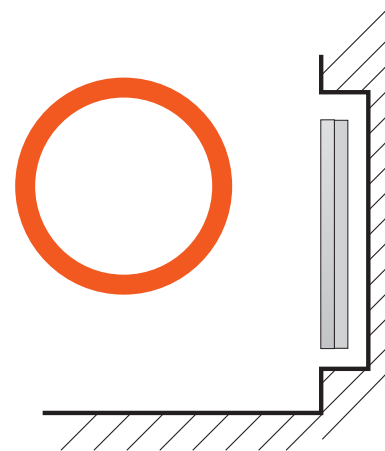
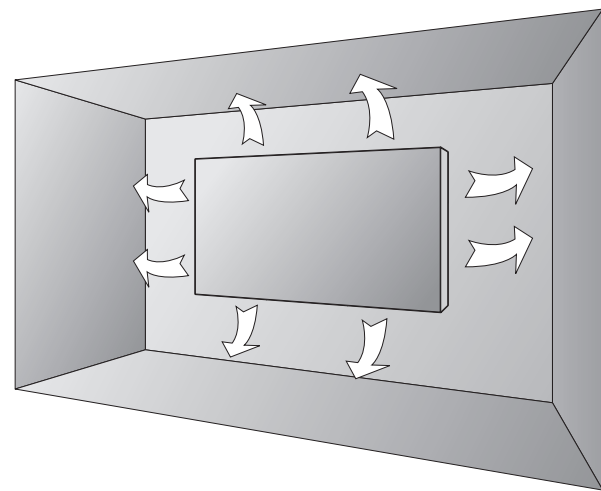

※ Ventilation space in front of product must be furnished for heat dispersion. If the front space of MLCD has to be sealed, there must be consideration for the heat dispersion in the rear side of MLCD.

► Do not cover the vent hole for the fan



-Carefully install product not to cover the fan air holes with any structural object. If the holes are covered with anything, the inner temperature can be raised rapidly and it can cause malfunctions.

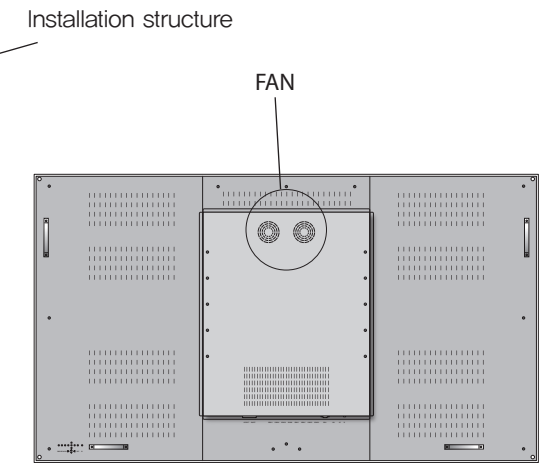
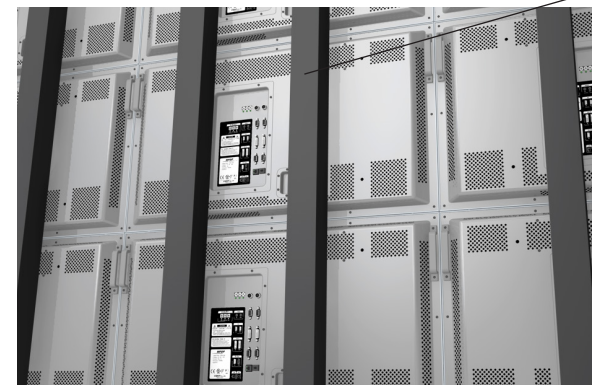

► Cleaning and Maintenance



-Regularly clean off the vent holes in the back of product sets. If the vent holes and the fan air holes are clogged with dust, it prevents the air flow inside of product sets. It can cause rapid increase of the inner temperature and may cause malfunctions. Clean off the vent holes and the fan air holes with a vacuum cleaner regularly.

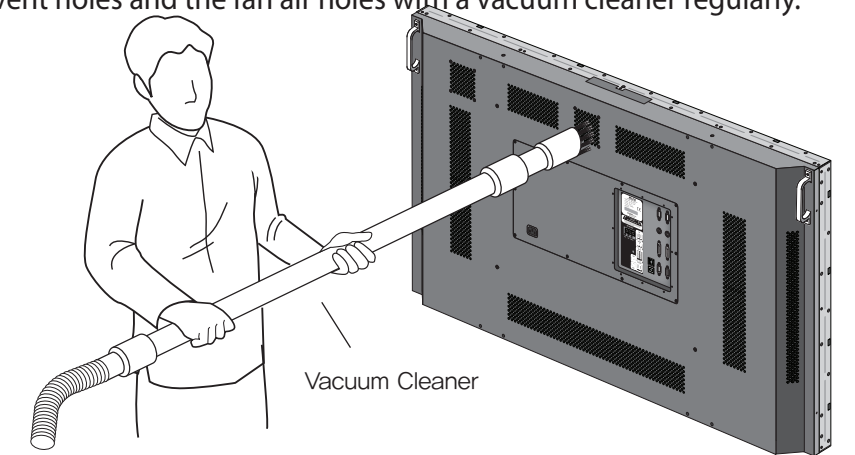

02. Safety Precautions

- If it operates abnormally, stop using it immediately.

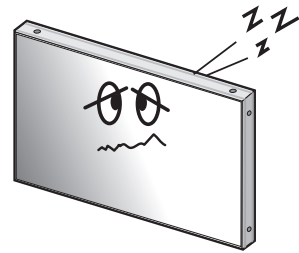

- Do not place any liquid-containing container on it. If the inside is wet, it may cause electric shock or fire.

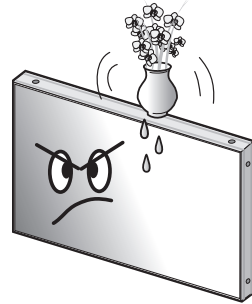

- Do not put any foreign material into the product. It may cause a failure or shorten the life span.

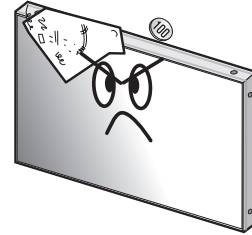

- Please refer to a specialized construction company for installing stand or wall mount unit. Otherwise, damage or injury may be caused.



- Do not touch the device when lightning strikes.

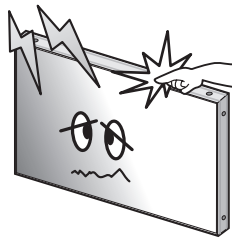

- Do not install in an unstable location. It may cause injury.

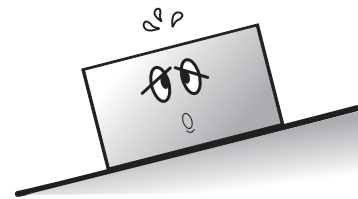

- Avoid any action to damage the power cord or power plug. It may cause fire or electric shock.

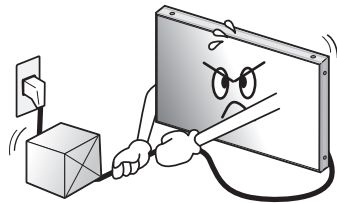

- Do not pull out the power plug with a wet hand. It may cause electric shock.

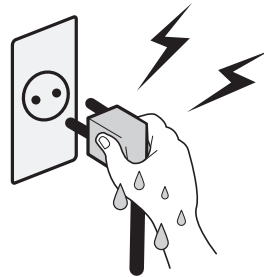

- Do not exceed ratings of AC outlet or extension cords. It may cause failure.

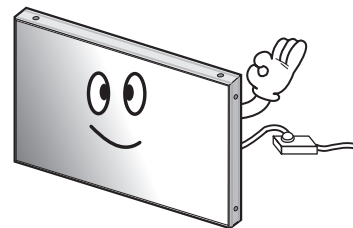

- Do not alter (or disassemble) the product. It may cause electric shock since high voltage is flowing inside.

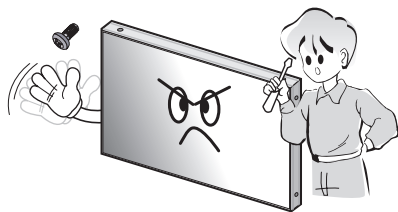

- Do not install the product where it may be exposed to direct sunlight or near any heating device. It may shorten the product's life span or cause failure.

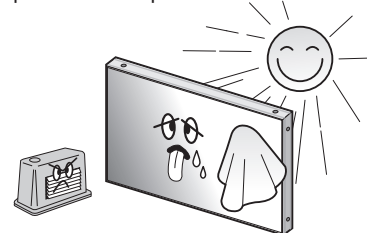

- Make sure the product is not covered with any object. If the ventilation hole is blocked, the inside temperature may rise to cause overheating resulting in fire.

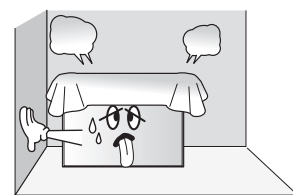

- Do not pull out or hang down the connection cable. It may damage the cord to cause fire or electric shock.

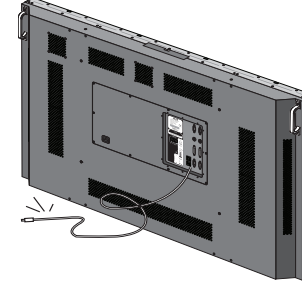

- Do not lean against the product or keep it leaned. It may cause injury or failure.

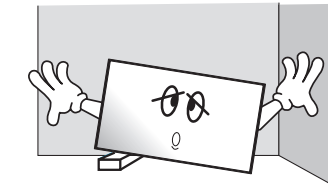

- Do not put it at any place with much humidity, dust, oil, smoke or steam. It may cause failure.

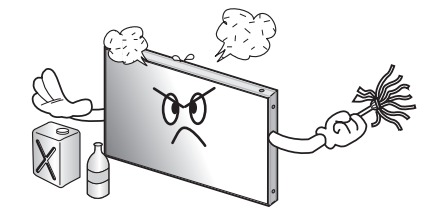

- Pull out the power plug by holding the plug. Otherwise, it may damage the power cord to cause fire or electric shock.

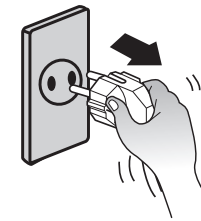

- If you do not want to use the product for a long time, keep the power plug unplugged to save electricity.
- The socket-outlet should be installed near the equipment and be easily accessible.

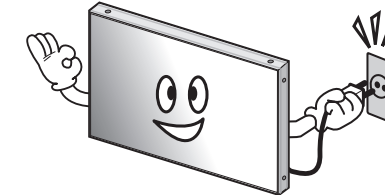

- Do not put any heavy object on it. It may cause failure.

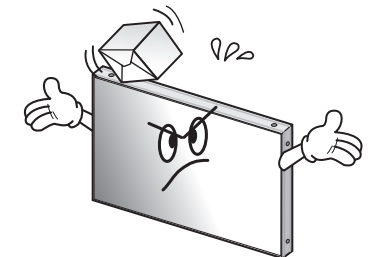

- Install the product on safe and flat surface.

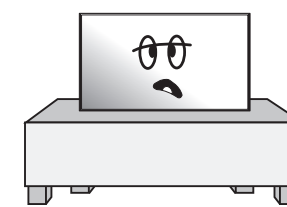

- Do not ride or step on the product. It may cause breakage when fallen down.

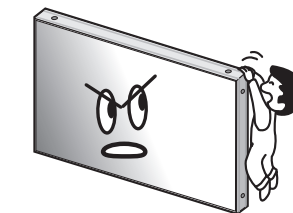

- When moving it, disconnect the connecting cable. Otherwise, it may damage the cable to cause fire or electric shock.

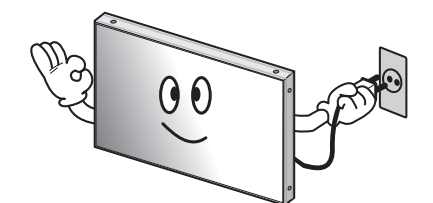

- Do not put candles on the product. If the liquid flows inside the product. It may cause electric shock or fire.

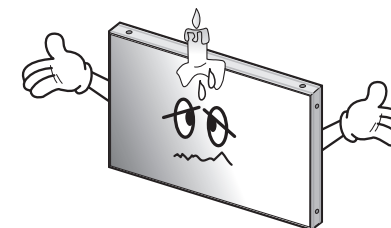

- Do not touch product's front surface with hand. Otherwise, the image quality can be lowered.

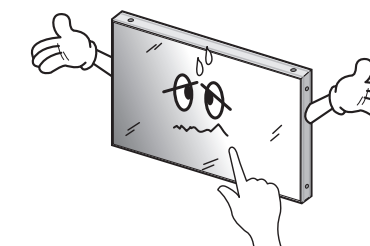

- Do not poke the front screen with sharp material. It may damage the screen and may cause malfunction of the product.

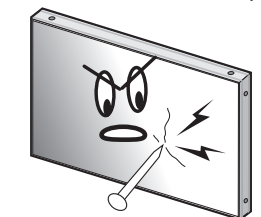

03. Names

▶ Front



▶ Rear

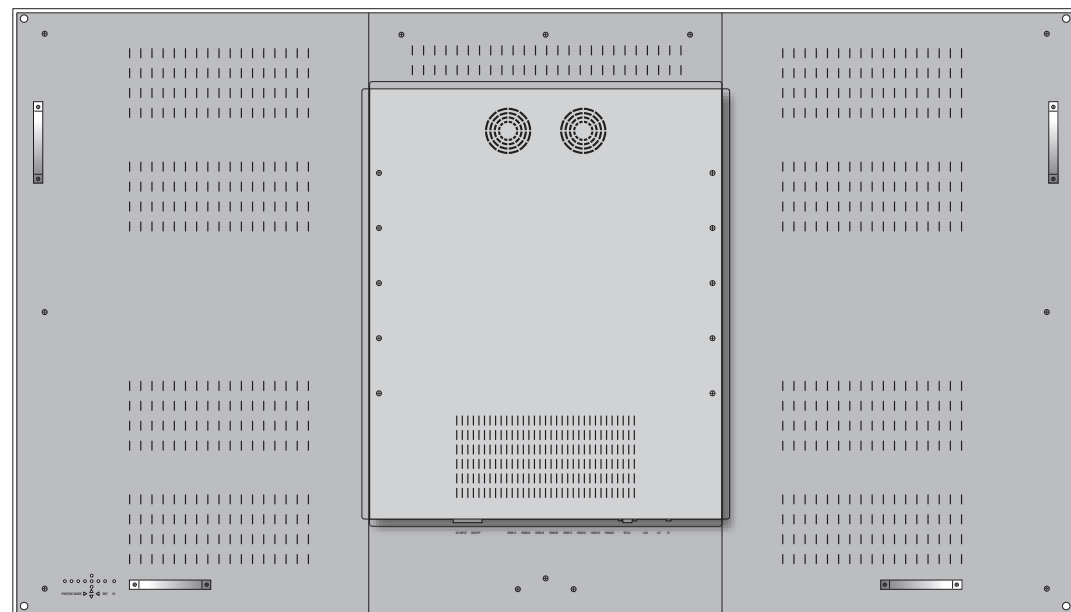

▶ Input Ports

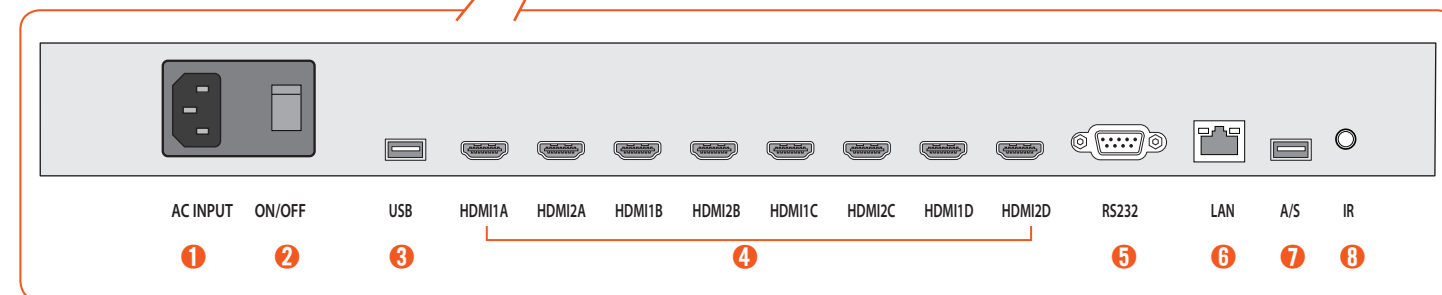
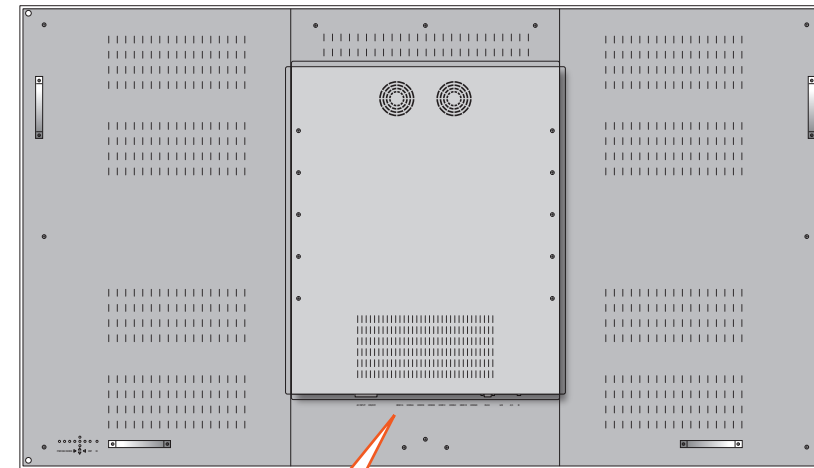

1. AC Input

AC 100V ~ 240V, 50/60Hz

2. ON/OFF Switch

Turn on or off the display.

3. USB

For touch sensor(Only Touch Model)

4. HDMI

Group 1(1A, 1B, 1C, 1D)
Group 2(2A, 2B, 2C, 2D)

5. RS-232C

Display control via COM port or firmware upgrade (D-Sub 9pin)

6. LAN

Display control via Ethernet (RJ45)

7. A/S

Service port for firmware upgrade

8. IR

Remote controller input port

▶ KEY PAD

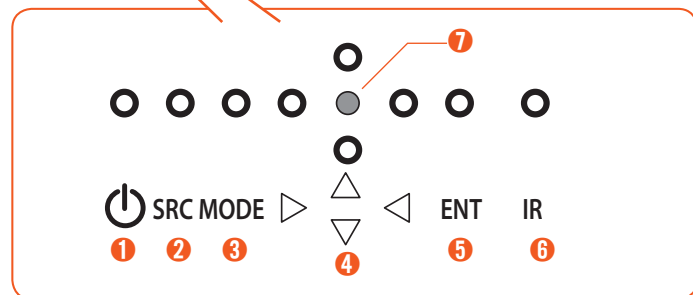
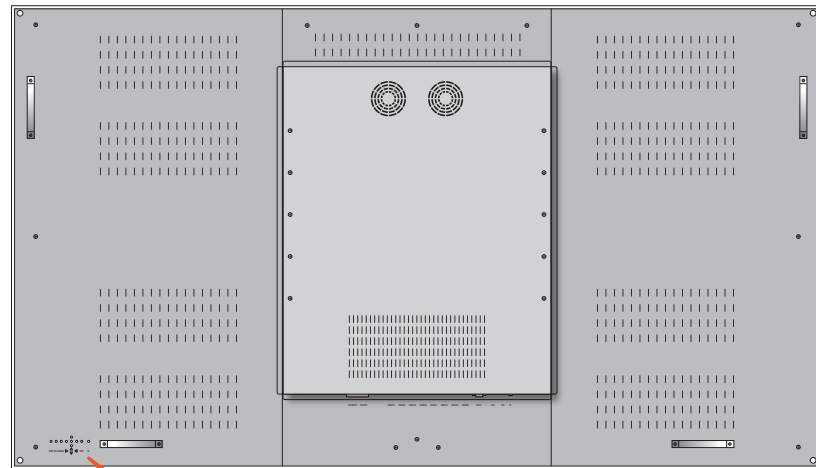

1. PWR (Power)

Turn on or off the display.

2. SRC (Input source selection)

Select HDMI input.

3. MODE (MENU)

Turn on or off the menu or select adjust menu.

4. Direction (up, down, left and right)

Move up, down, left or right direction on the menu screen.

5. ENT (Enter)

Select adjustment.

6. IR (IR Reception)

Receive the IR signal from remote controller

7. Power Indication Lamp

Indicate the power status.

▶ Remote Controller

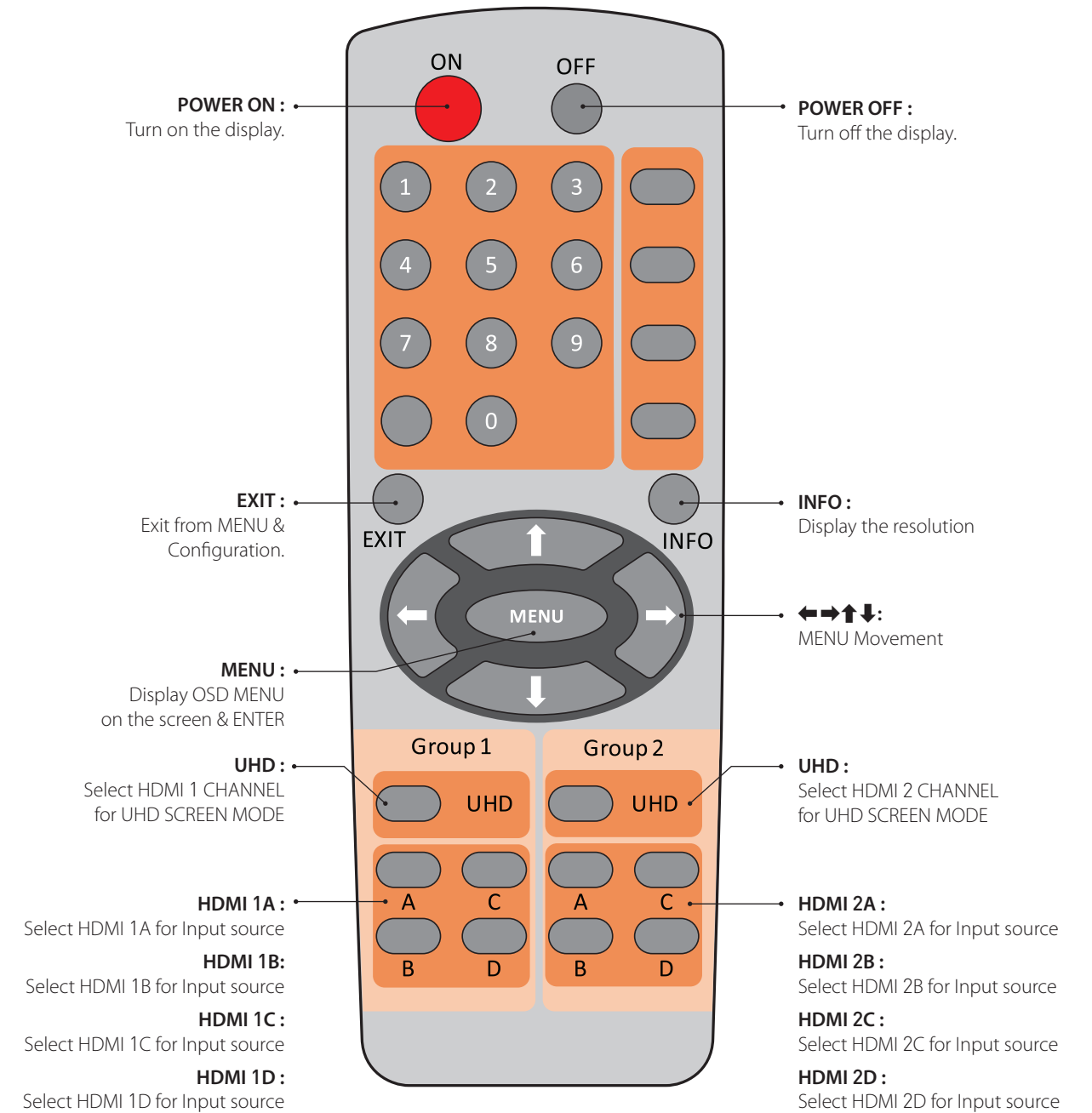

04. Cable Connection

- Do not connect or disconnect the signal cables while the display and the peripheral devices are turned on.
- The power must be turned off before connecting the signal cables or the peripheral devices.
- The power cord must be firmly inserted to prevent unexpected disconnection.

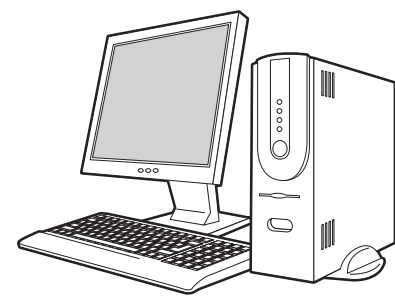

Ethernet Control PC

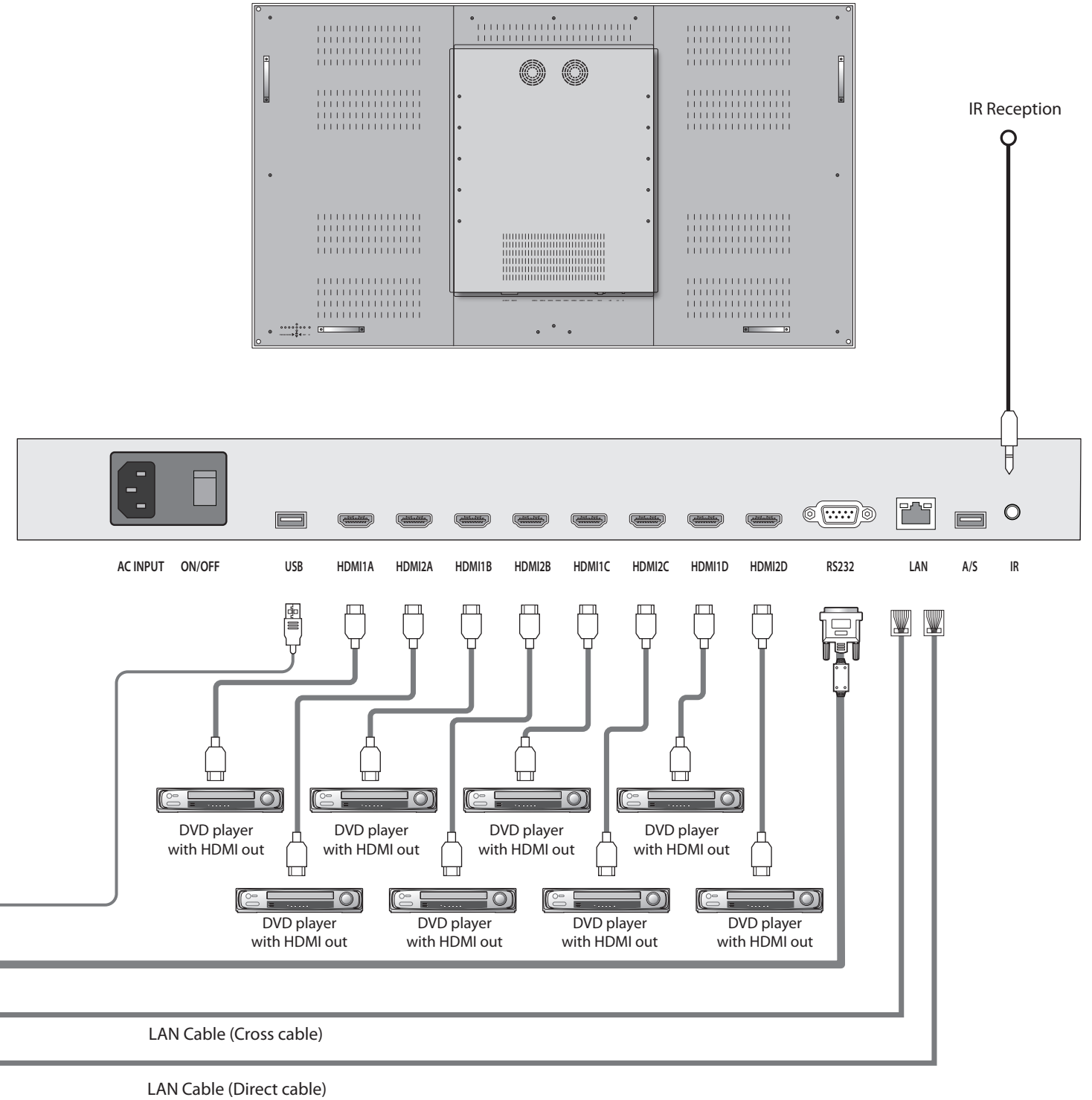
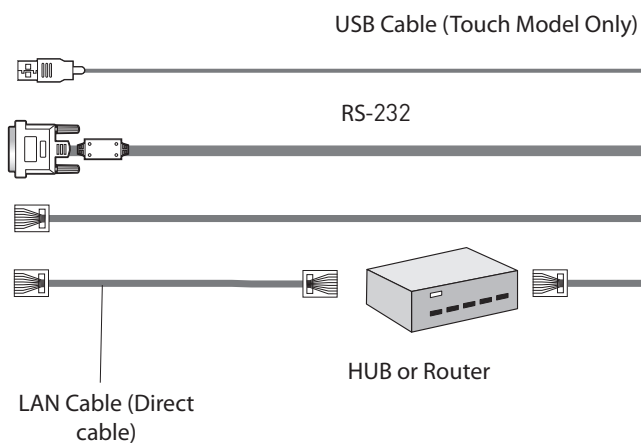

05. How to use Remote Controller

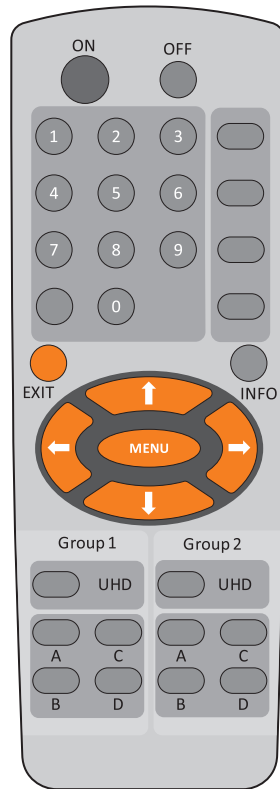

1. MENU button

- OSD MENU will be displayed by pressing MENU button.

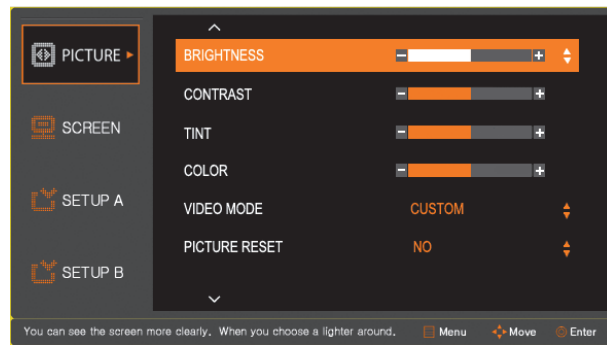

2. Direction buttons for movement

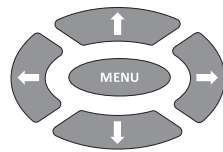

- Use ←→ buttons or MENU button to adjust menu items.
- Use ↓↑ buttons to move to adjust sub-menu items.

3. EXIT button

- Press EXIT button to exit from the MENU after adjustment.

4. INFO button

- The display information for the screen at the moment is displayed at the upper left corner of the screen.
- ex) Input HDMI 1A - Ex) UHD

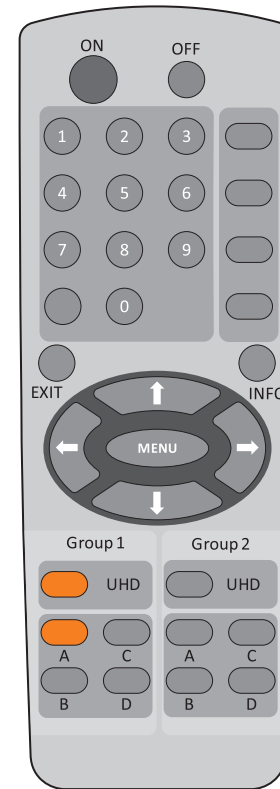
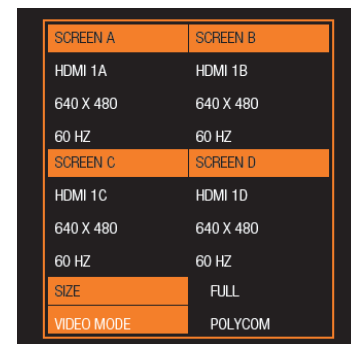
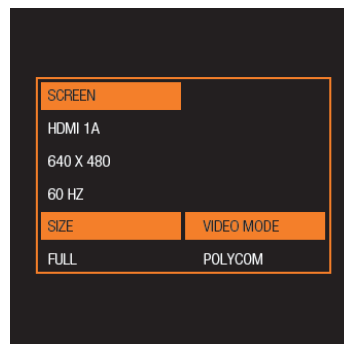

5. UHD button

- Input A, Input B, Input C and Input D will be displayed on the screen simultaneously.

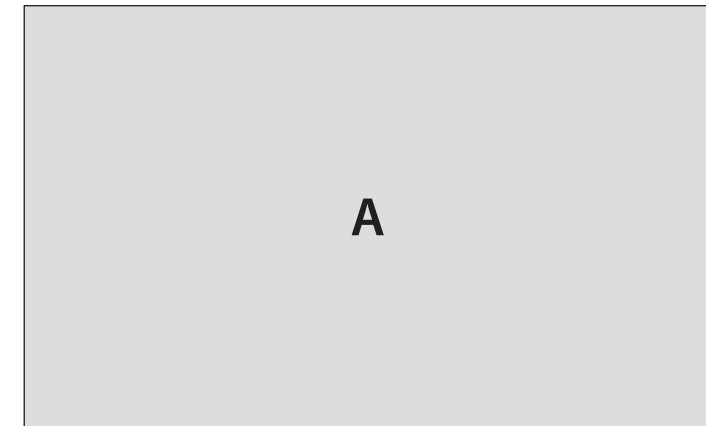

6. A, B, C, D button

- Selected input will be displayed on the whole screen.

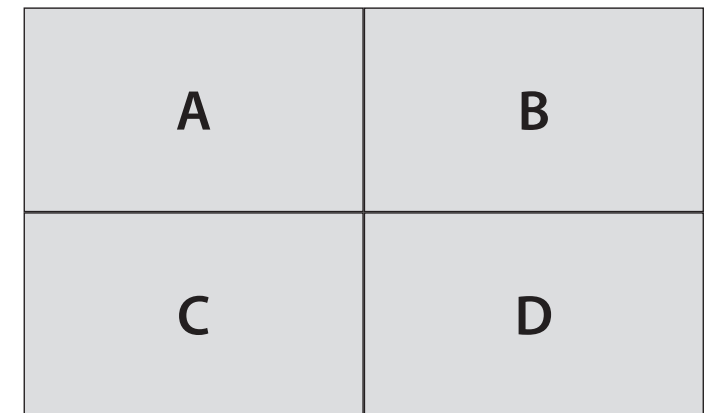

06. Configuration

PICTURE Adjustment

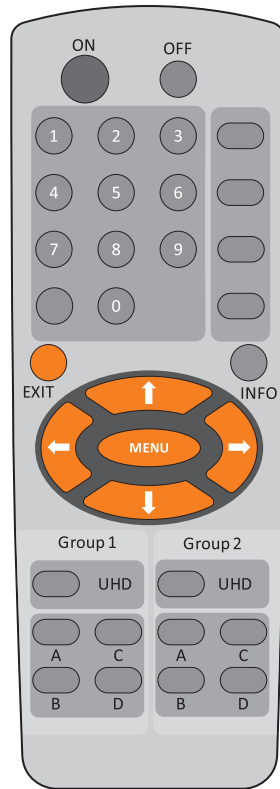

- BRIGHTNESS, CONTRAST, TINT, COROR, VIDEO MODE, and PICTURE RESET can be adjusted in the PICTURE MENU.

1. Press MENU button.

- Press MENU button to display OSD MENU on the screen.

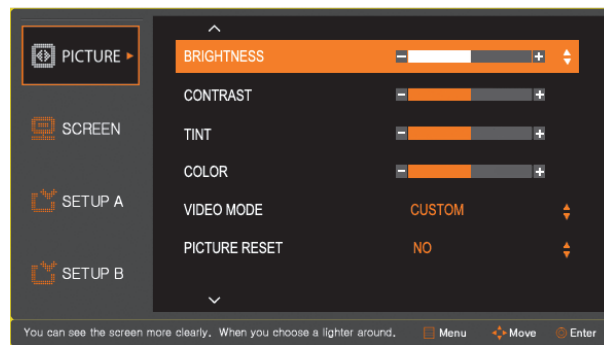

2. Select MENU.

- Use ↓ ↑ buttons to move to PICTURE MENU.
- When PICTURE item is selected, press MENU button to move into the sub-menu.

3. Adjust the value.

- BRIGHTNESS, CONTRAST, TINT, COLOR and VIDEO MODE can be adjusted.
- Each of the value can be adjusted by pressing ← → buttons.

4. Exit from the MENU

- Press EXIT button to getting out of OSD MENU.

▶ BRIGHTNESS ADJUSTMENT

- Screen brightness can be adjusted.
- The brightness of black color at the dark side of the screen can be adjusted.

1. Select BRIGHTNESS from PICTURE Menu.

- Select BRIGHTNESS and move ← → buttons to adjust the value.

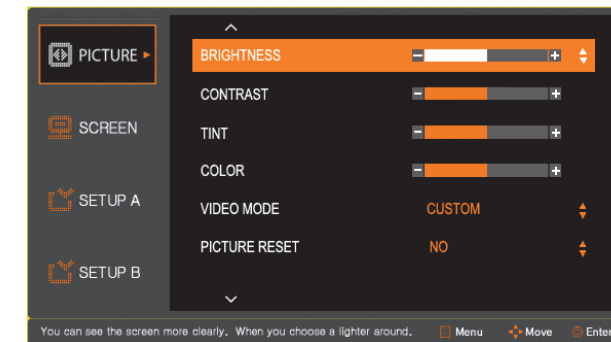

2. EXIT MENU

- Press Exit button to exit from the menu after adjusting the value.

▶ CONTRAST ADJUSTMENT

- The brightness of white color at the bright side of the screen can be adjusted.

1. Select CONTRAST from PICTURE menu.

- Select CONTRAST and move ← → buttons to adjust the value.

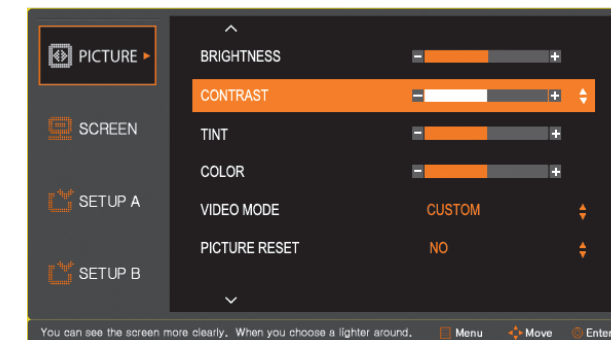

2. EXIT MENU

- Press Exit button to exit from the menu after adjusting the value.

▶ TINT ADJUSTMENT

- Adjust Red and Green color of the screen.

1. Select TINT from PICTURE Menu.

- Select TINT and move ◀ ▶ buttons to adjust the value.

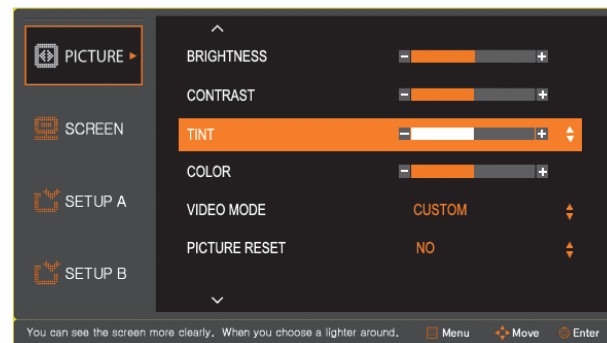

2. EXIT MENU

- Press Exit button to exit from the menu after adjusting the value.

▶ COLOR ADJUSTMENT

- Adjust the depth of the screen color.
- The depth of color will be thicker as the value goes higher.
- As the value goes lower, the depth of color will be getting thinner and go to black and white.

1. Select COLOR from PICTURE Menu.

- Select COLOR and move ◀ ▶ buttons to adjust the value.

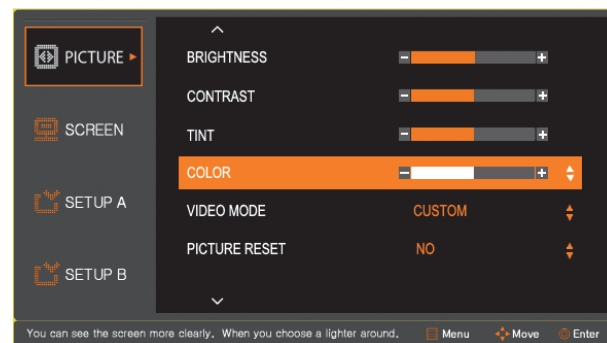

2. EXIT MENU

- Press Exit button to exit from the menu after adjusting the value.

▶ VIDEO MODE SELECTION

- Adjust the color temperature of the screen.

1. Select VIDEO MODE from PICTURE Menu.

- Select VIDEO MODE and move ↓ ↑ buttons to select a VIDEO MODE of your choice among POLYCOM, COOL, NATURAL, WARM and CUSTOM.



» CUSTOM configuration

1. Select CUSTOM from VIDEO MODE.

- Detailed values for RGB can be controlled by pressing MENU button after selecting CUSTOM.

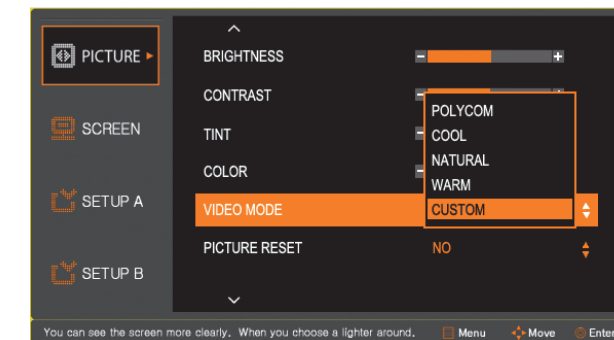

2. Adjust values

- USER-R O, USER-G O, and USER-B O mean OFFSET RED, OFFSET GREEN, and OFFSET BLUE, respectively. USER-R, USER-G and USER-B are GAIN RED, GAIN GREEN, and GAIN BLUE.
- Each value can be adjusted by ◀ ▶ buttons.

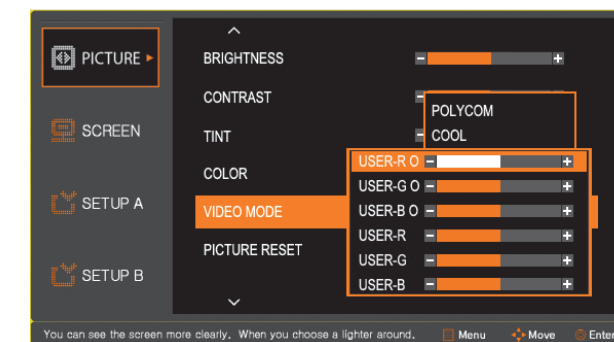

▶ PICTURE RESET

- Initialize the values of PICTURE MENU.

1. Select PICTURE RESET from PICTURE menu.

- Press MENU button to display OSD.
- Use ↓ ↑ buttons to move to PICTURE RESET and press MENU button.

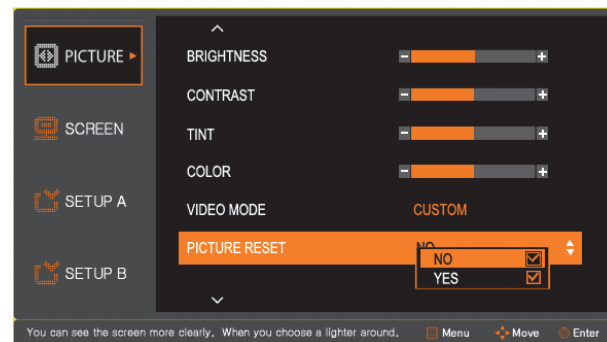

2. Initialize the values

- Select YES or NO for initializing PICTURE RESET menu.
- Use ↓ ↑ buttons to move to YES and press MENU button to initialize the value.

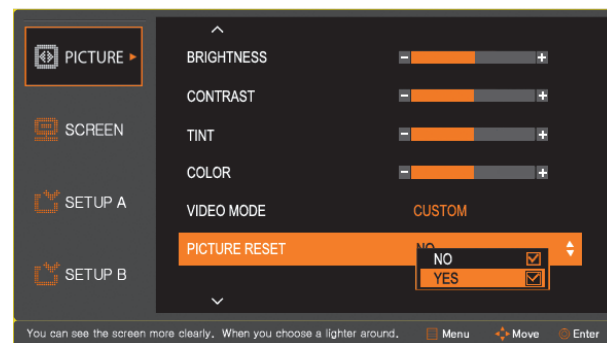

3. EXIT MENU

- Press Exit button to exit from the menu after reset.

■ SCREEN ADJUSTMENT

- H POSITION, V POSITION, ASPECT RATIO, VIDEO MUTE, SCREEN MODE, and SCREEN RESET can be adjusted in the SCREEN MENU.

1. Press MENU button.

- Press MENU button to display OSD MENU on the screen.

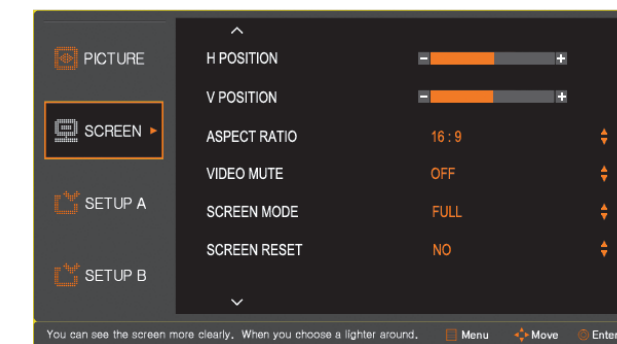

2. Select SCREEN menu

- Use ↓ ↑ buttons to move SCREEN menu.
- When SCREEN is selected, press MENU button to move to the sub-menu.
- H POSITION, V POSITION, ASPECT RATIO, VIDEO MUTE, and SCREEN MODE can be adjusted.

3. EXIT MENU

- Press Exit button to exit from the menu.

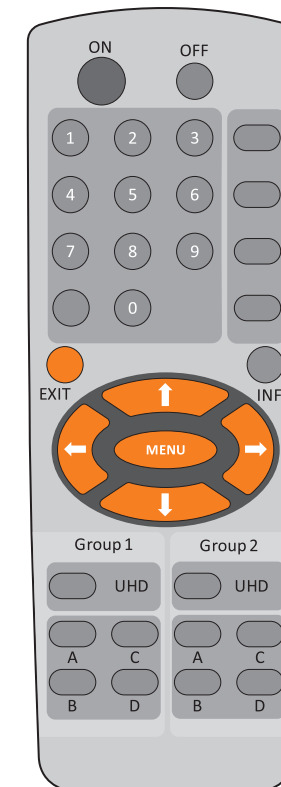

▶ H POSITION

- Adjust the horizontal position of the display image on the screen.

1. Select H POSITION from SCREEN menu.

- Adjust H POSITION values with ◀ ▶ buttons after selecting H POSITION.

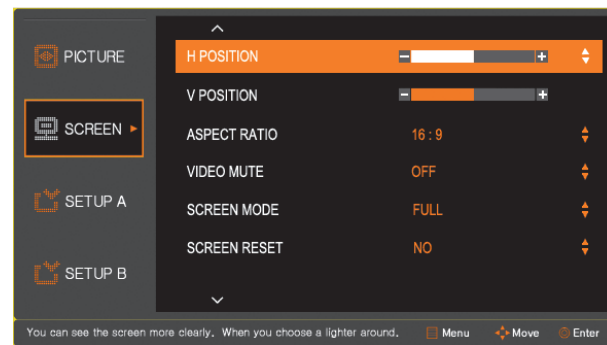

2. EXIT MENU

- Press Exit button to exit from the menu.

▶ V POSITION

- Adjust the vertical position of the display image on the screen.

1. Select V POSITION from SCREEN menu.

- Adjust V POSITION values with ◀ ▶ buttons after selecting V POSITION.

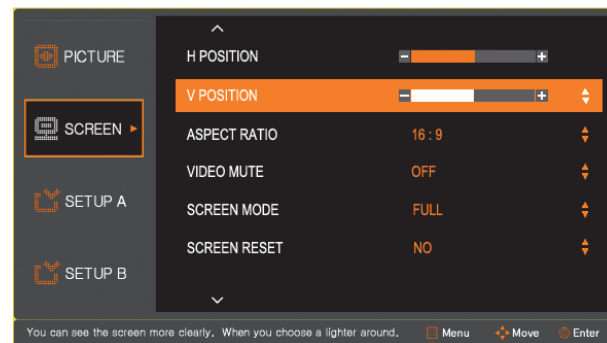

2. EXIT MENU

- Press Exit button to exit from the menu.

▶ ASPECT RATIO Configuration

- Adjust screen ratio.
- FULL – All the input will be displayed with the screen ratio of 16:9.
- ASPECT – All the input will be displayed with their original screen ratio.

1. Select ASPECT RATIO from SCREEN menu.

- Move to the sub-menu by pressing MENU button after selecting ASPECT RATIO.

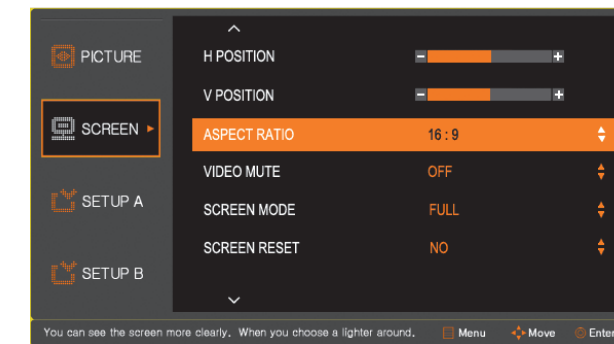

2. Select ASPECT RATIO value.

- 16:9 or 4:3 screen ration can be selected.
- Use ↓ ↑ buttons to move into the sub-menu and press MENU button again to select the screen ratio.

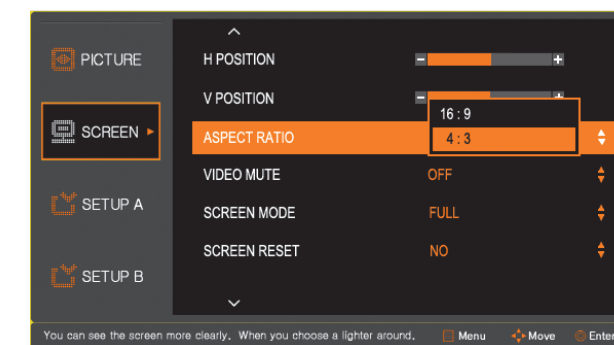

3. EXIT MENU

- Press Exit button to exit from the menu.

▶ VIDEO MUTE

- Display the input image on the screen.
- ON- Display on the screen
- OFF- No screen display (Black screen)

1. Select VIDEO MUTE from SCREEN menu.

- Configure VIDEO MUTE value by pressing MENU button after selecting VIDEO MUTE.

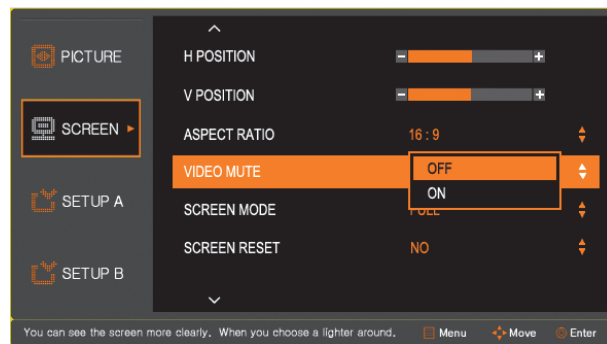

2. Select VIDEO MUTE value.

- Use ↓ ↑ buttons to move to ON or OFF.
- To select VIDEO MUTE, move to ON and press MENU button.
- Move to OFF and press MENU button to deselect VIDEO MUTE.

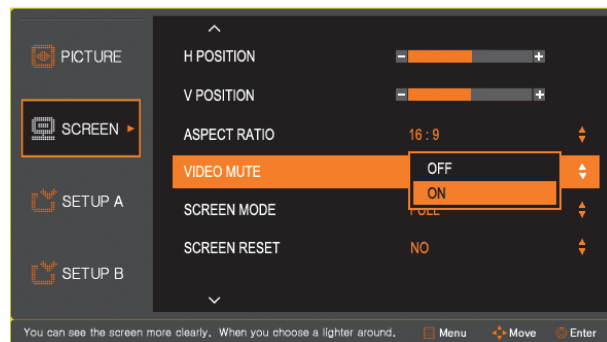

3. EXIT MENU

- Press Exit button to exit from the menu.

▶ SCREEN RESET Adjustment

- Initialize the values of SCREEN MENU.

1. Select SCREEN RESET from SCREEN menu .

- Press MENU button to display OSD.
- Use ↓ ↑ buttons to move to SCREEN RESET and press MENU button..

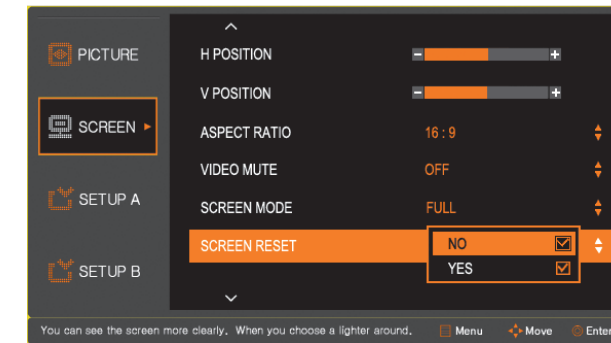

2. Initialize the previously adjusted values.

- Select YES or NO for initializing SCREEN menu.
- Use ↓ ↑ buttons to move to YES and press MENU button to initialize the value.

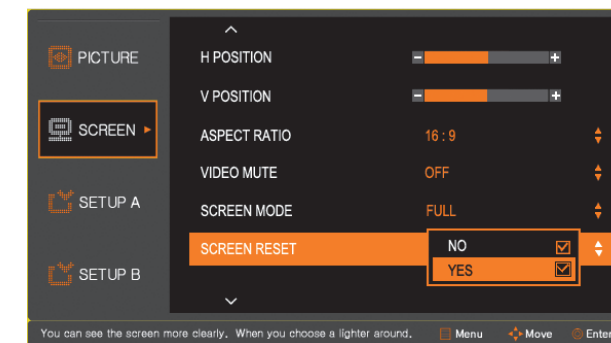

3. EXIT MENU

- Press Exit button to exit from the menu.

■ SETUP A Configuration

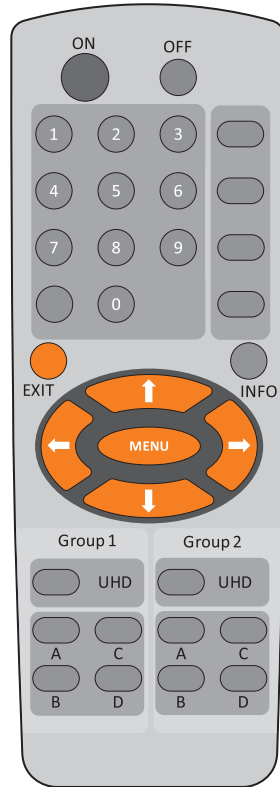

- **AUTO POWER, DISPLAY MODEL, FIRMWARE VERSION, LAN SETTING, SERIAL SETTING, OSD, and SETUP A RESET can be adjusted in SETUP A MENU.**

1. Press MENU button.

- Press MENU button to display OSD MENU on the screen.

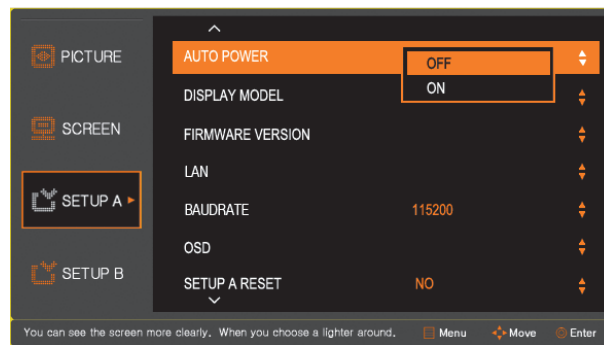

2. Select SETUP A.

- Use ↓↑ buttons to move to SETUP A menu.
- Press MENU button to move into the sub-menu.
- AUTO POWER, LAN SETTING, SERIAL SETTING, and OSD menu can be adjusted.
- DISPLAY MODEL and FIRMWARE VERSION also can be checked.

3. Each sub-menu can be configured.

- Use ↓↑ buttons to move to the sub-menus you want to adjust.
- To configure the sub-menu, move to the sub-menu and press MENU button to enter.

4. EXIT MENU

- Press Exit button to exit from the menu.

▶ AUTO POWER Configuration

- **The display set can be turned on automatically as the power is on.**
- **ON – Select the function for automatic turn on.**
- **OFF -Deselect the function.**

1. Select AUTO POWER from SETUP A menu.

- Use ↓↑ buttons to select ON or OFF.
- Move to ON and press MENU button to select and move to OFF and press MENU button to deselect.



2. EXIT MENU

- Press Exit button to exit from the menu.

▶ DISPLAY MODEL Configuration

- **It displays the model information.**

1. Select DISPLAY MODEL from SETUP A menu.

- Move to DISPLAY MODEL and press MENU button to check current model name.

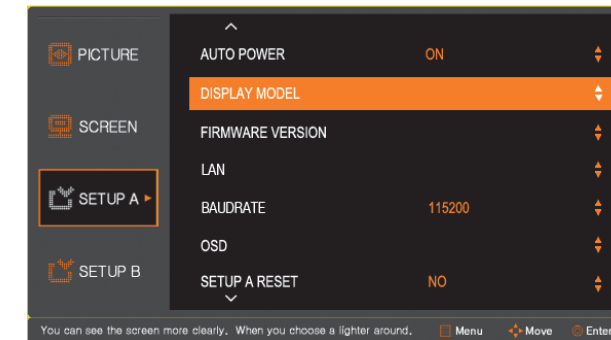

2. EXIT MENU

- Press Exit button to exit from the menu.

► FIRMWARE Configuration

- It displays the firmware version information.

1. Select FIRMWARE from SETUP A menu.

- Move to FIRMWARE and press MENU button to check current firmware version.

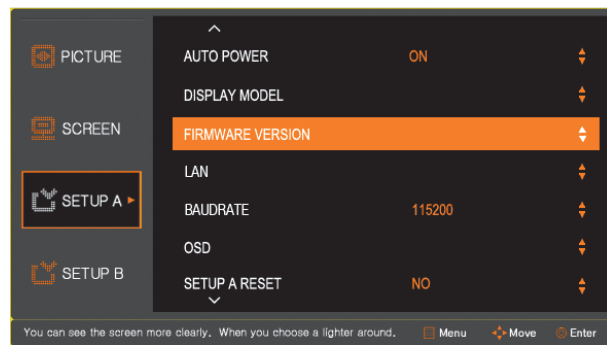

2. EXIT MENU

- Press Exit button to exit from the menu.

► LAN Configuration

- It configures the IP address of the set to control via Ethernet.

1. Select LAN from SETUP A menu.

- Move to LAN and press MENU button to check current LAN configuration.
- Configurations for DHCP ENABLE or DISABLE, IP ADDRESS, SUBNET MASK, DEFAULT GATEWAY, DNS PRIMARY & SECONDARY, and PORT can be checked.

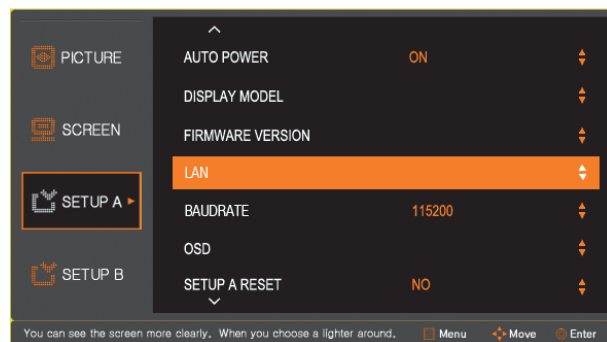

2. EXIT MENU

- Press Exit button to exit from the menu.

► BAUD RATE Configuration

- It adjusts the communication rate to control the set via RS-232C.

1. Select BAUD RATE from SETUP A menu.

- Move to BAUD RATE and press MENU button.

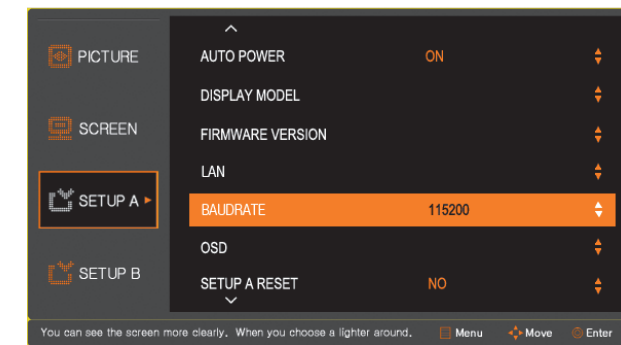

2. Press MENU button to move into the sub-menu of BAUD RATE.

- Use ↓ ↑ buttons to adjust values.
- Press MENU button to select a value.

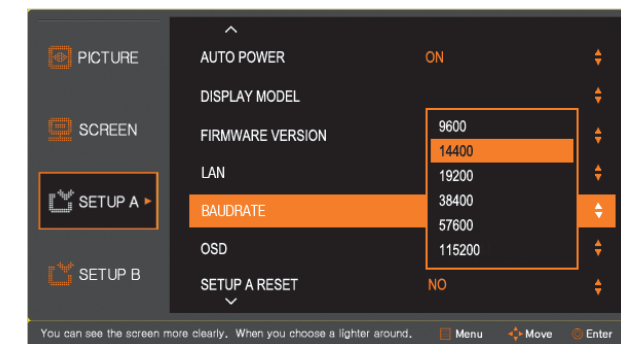

3. EXIT MENU

- Press Exit button to exit from the menu.

▶ OSD Configuration

- It configures OSD menu.

1. Select OSD from SETUP A menu.

- Move to OSD and press MENU button.

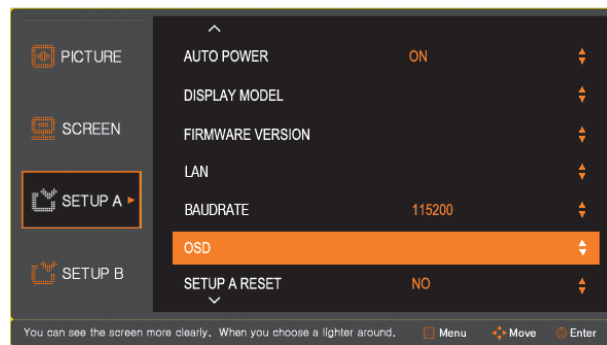

» TURN OFF Configuration

- TURN OFF – Select the duration time of OSD on the screen.

1. Select TURN OFF.

- Move to TURN OFF and press MENU button.

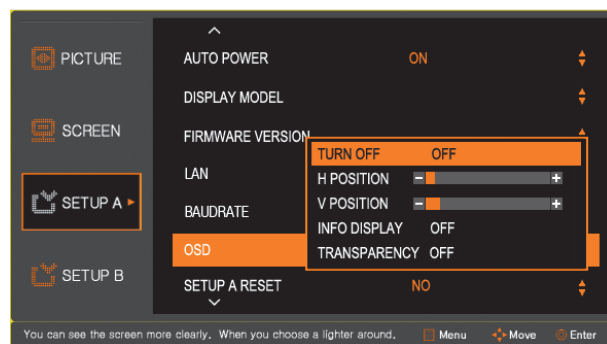

2. Select the sub-items of TURN OFF

- Select the duration time for OSD CONTRON MENU or TURN OFF

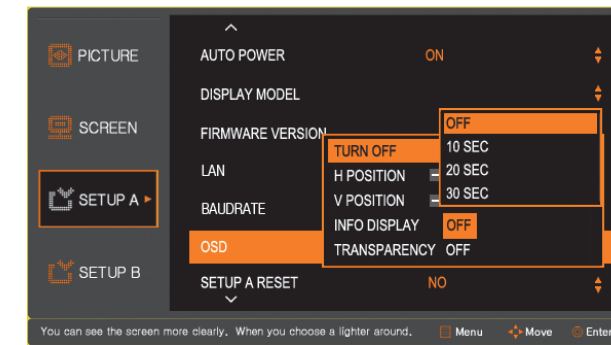

3. EXIT MENU

- Press Exit button to exit from the menu.

» OSD POSITION Configuration

- **H POSITION** – Select the horizontal position of OSD.
- **V POSITION** - Select the vertical position of OSD.

1. Select OSD H POSITIION

- Use ← → buttons to adjust OSD H POSITION value.

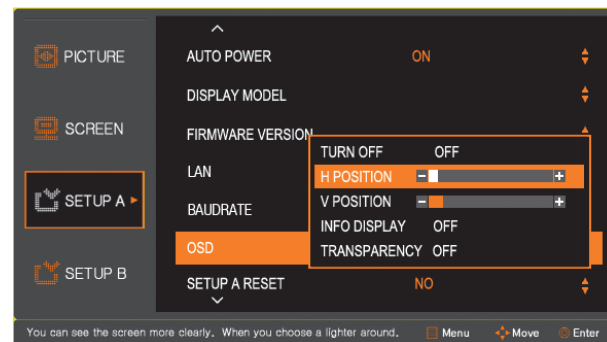

2. Select OSD V POSITIION

- Use ← → buttons to adjust OSD V POSITION value.

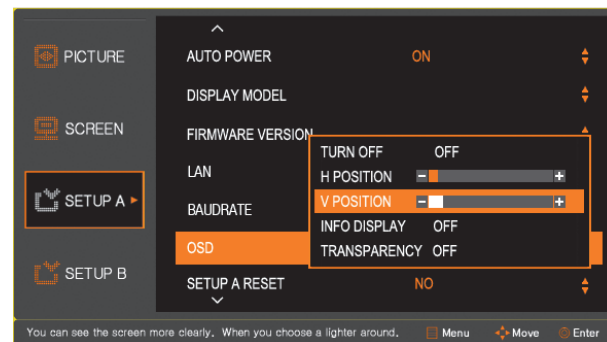

3. EXIT MENU

- Press Exit button to exit from the menu.

» INFO DISPLAY Configuration

- **INFO DISPLAY** - Select the duration time of INFO OSD.

1. Select INFO DISPLAY

- Turn on or off INFO DISPLAY OSD and select display duration time.
- Use ↓ ↑ buttons to select ON or OFF.
- Press MENU button after selecting ON or OFF.

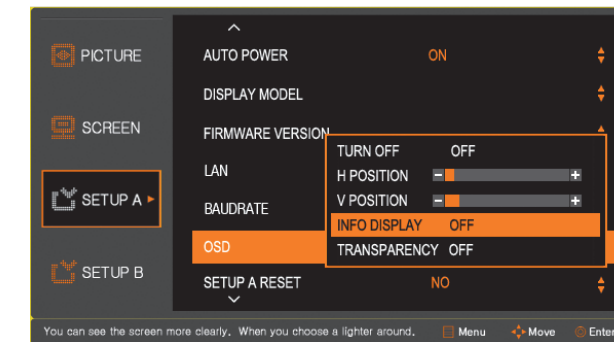

2. EXIT MENU

- Press Exit button to exit from the menu.

» TRANSPARENCY Configuration

- **TRANSPARENCY** – Select the transparent percentage of OSD.

1. Select TRANSPARENCY

- The transparency of OSD can be adjusted.
- Use ↓ ↑ buttons to select ON or OFF.
- Press MENU button after selecting ON or OFF.

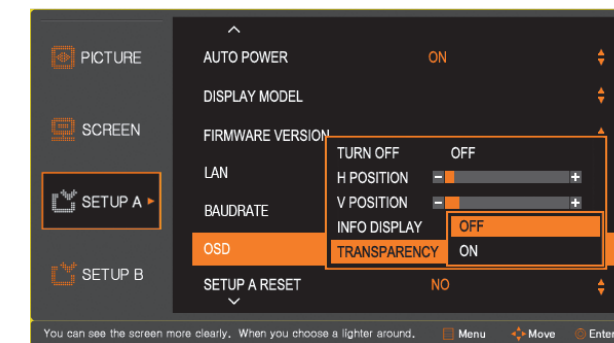

2. EXIT MENU

- Press Exit button to exit from the menu.

▶ SETUP A RESET Configuration

- Initialize the previously adjusted values of SETUP A RESET MENU.

1. Select SETUP A RESET from SETUP A menu.

- Press MENU button to display OSD.
- Use ↓ ↑ buttons to move to SETUP A RESET and press MENU button.

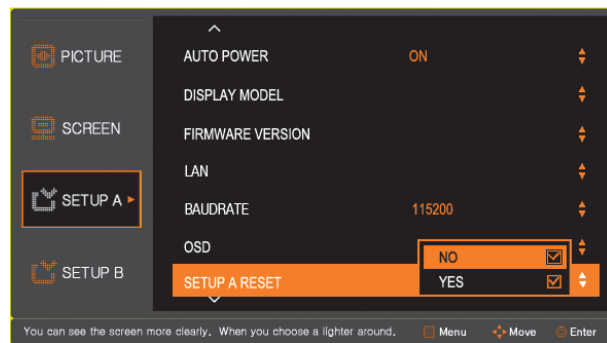

2. Initialize the previously adjusted values.

- Select YES or NO for initializing SETUP A menu.
- Use ↓ ↑ buttons to move to YES and press MENU button to initialize the value.

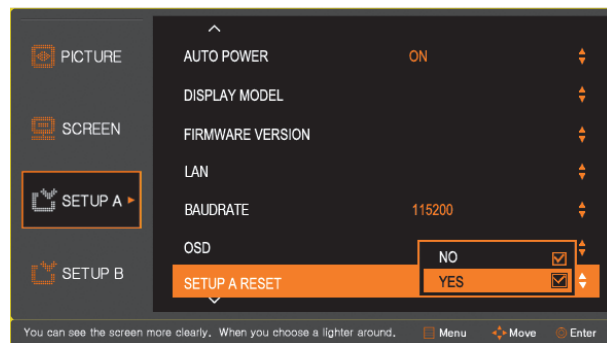

3. EXIT MENU

- Press Exit button to exit from the menu.

■ SETUP B Adjustment

- INFORMATION, POWER ON SOURCE, SETUP B RESET, and FACTORY RESET can be adjusted in SETUP B MENU.

1. Press MENU button.

- Press MENU button to display OSD MENU on the screen.

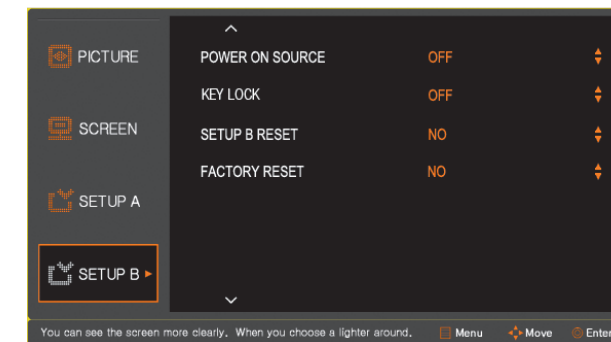

2. Select SETUP B menu.

- Use ↓ ↑ buttons to move to SETUP B.
- Press MENU button to move into the sub-menu.
- POWER ON SOURCE, SET UP B RESET, and FACTORY RESET can be adjusted.
- Current display configuration can be displayed by INFORMATION function.

3. Sub-menus can be configured.

- Use ↓ ↑ buttons to move to the menus you want to adjust.
- To configure the sub-menu, move to the sub-menu and press MENU button to enter.

4. EXIT MENU

- Press Exit button to exit from the menu.

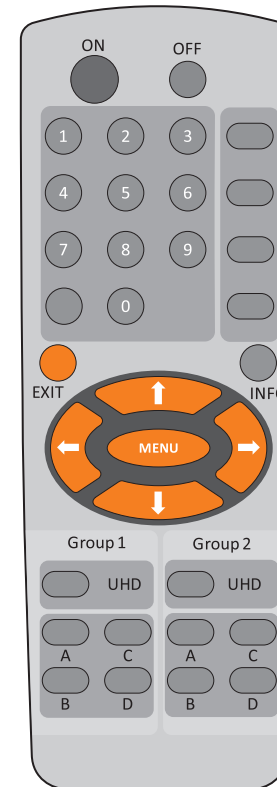

▶ POWER ON SOURCE Configuration

- Select the default input source for power on. (Default: HDMI 1A)
- OFF – Display the input source right before power off.

1. Select POWER ON SOURCE from SETUP B menu

- Use ↓ ↑ buttons to move to POWER ON SOURCE



2. Press MENU button to move into the sub-menu.

- Select the input source mode to detect at the time of power on.
- Use ↓ ↑ buttons to move to the item you want to select and press MENU button.

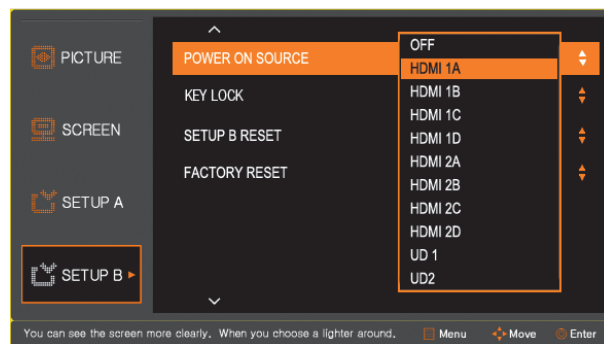

3. EXIT MENU

- Press Exit button to exit from the menu.

▶ KEY LOCK Configuration

- It restricts key strokes to prevent any of expected set activities.
- ON – Key buttons will not work.
- OFF – Key buttons will work.

1. Select KEY LOCK from SETUP B menu.

- Use ↓ ↑ buttons to move to KEY LOCK and press MENU button.

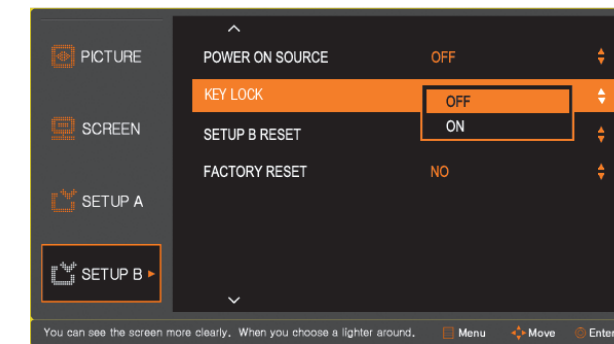

2. Adjust KEY LOCK.

- Use ↓ ↑ buttons to move to ON or OFF.
- Move to ON and press MENU button to activate KEY LOCK.
- To deactivate KEY LOCK, move to OFF and press MENU button.

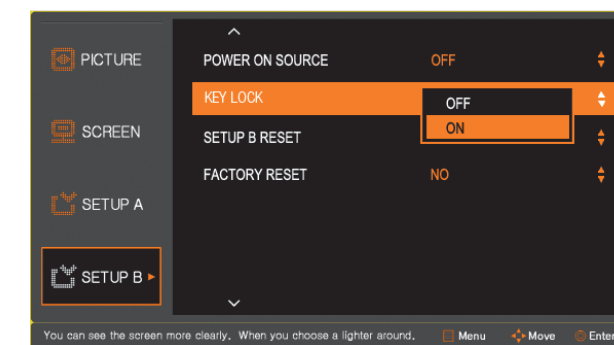

3. EXIT MENU

- Press Exit button to exit from the menu.

▶ SETUP B RESET Configuration

- Initialize the previously adjusted values of SCREEN B MENU.

1. Select SETUP B RESET from SETUP B menu.

- Press MENU button to display OSD.
- Use ↓ ↑ buttons to move to SETUP B RESET and press MENU button.

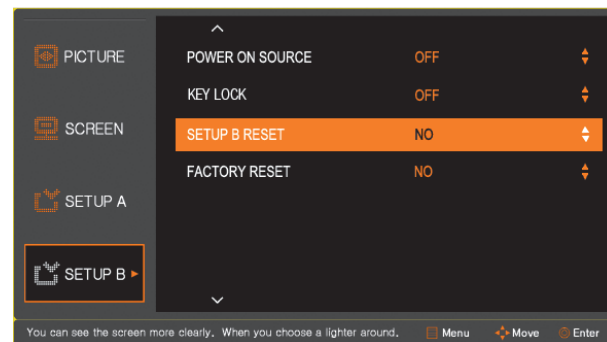

2. Initialize the previously adjusted values.

- Select YES or NO for initializing SETUP B menu.
- Use ↓ ↑ buttons to move to YES and press MENU button to initialize the value.

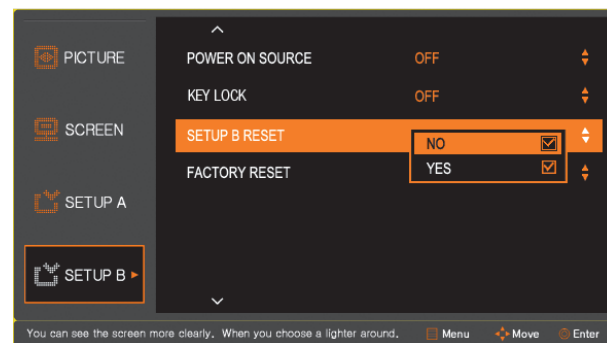

3. EXIT MENU

- Press Exit button to exit from the menu.

▶ FACTORY RESET Configuration

- Initialize the previously adjusted values of the set to the factory level. Every configuration will be initialized.

1. Select FACTORY RESET from SETUP B menu.

- Press MENU button to display OSD.
- Use ↓ ↑ buttons to move to FACTORY RESET and press MENU button.

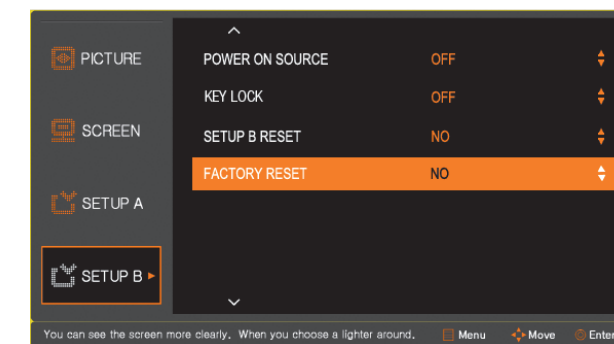

2. Initialize the previously adjusted values.

- PICTURE, SCREEN, SETUP A and SETUP B menus can be initialized to the factory level.
- Select YES or NO for initialization.
- Use ↓ ↑ buttons to move to YES and press MENU button to initialize the value.

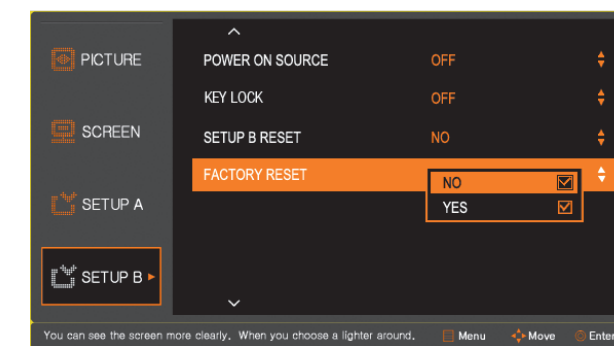

3. EXIT MENU

- Press Exit button to exit from the menu.

07. User guide for UHD Graphic

- This display supports UHD (Ultra High Definition; Resolution 3840 X 2160) resolution.
- This display unit can display UHD images by collecting 4 different FHD (Full High Definition; Resolution 1920 X 1080) input simultaneously from a PC that can make 4 separate FHD output.
- So, it requires a graphic card that has at least 4 FHD output ports and capable to compose one screen image with the 4 separate input. (e.g. AMD Eyefinity)
- You may use any graphic card that satisfies above mentioned condition besides the recommended MSI 7970. However, all the output ports must be the same interface. (e.g. 4 HDMI ports, 4 DVI ports, or 4 DP ports, etc)
- Even though the output ports are not same, it still can display UHD image but the screen image may not be displayed properly. (e.g. 2 DVI ports & 2 DP ports)

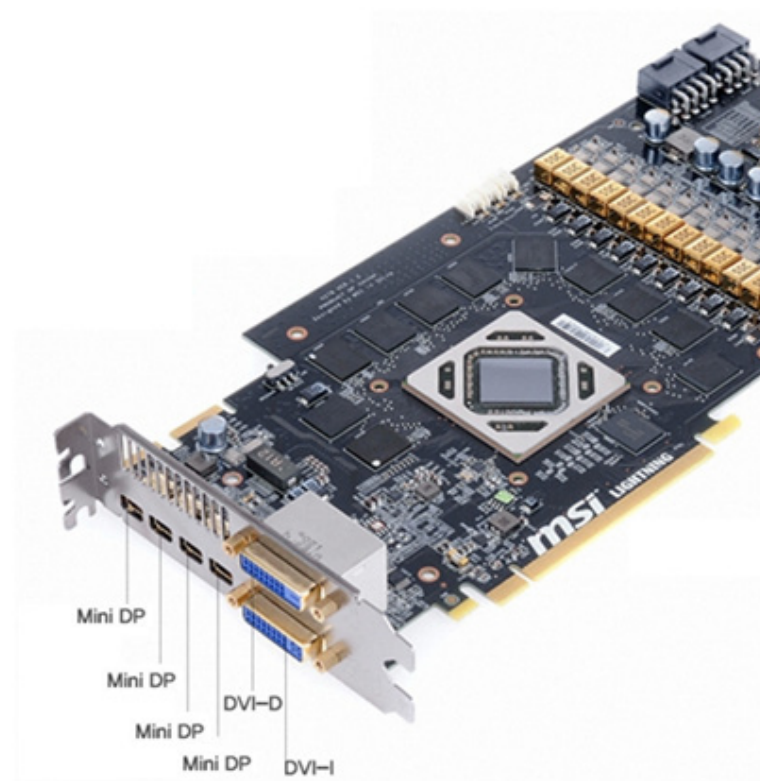

< MSI Radeon HD 7970 R7970 Lightning D5 3GB >

■ Cable connection

- Connect the output ports of the graphic card and the input ports of the display using the input port UHD group 1 (HDMI1A, HDMI1B, HDMI1C, HDMI1D) or UHD group 2 (HDMI2A, HDMI2B, HDMI2C, HDMI2D) as shown below. Simply, 4 outputs from the graphic card should be connected to the input ports in a same group, UHD group 1 or UHD group 2.

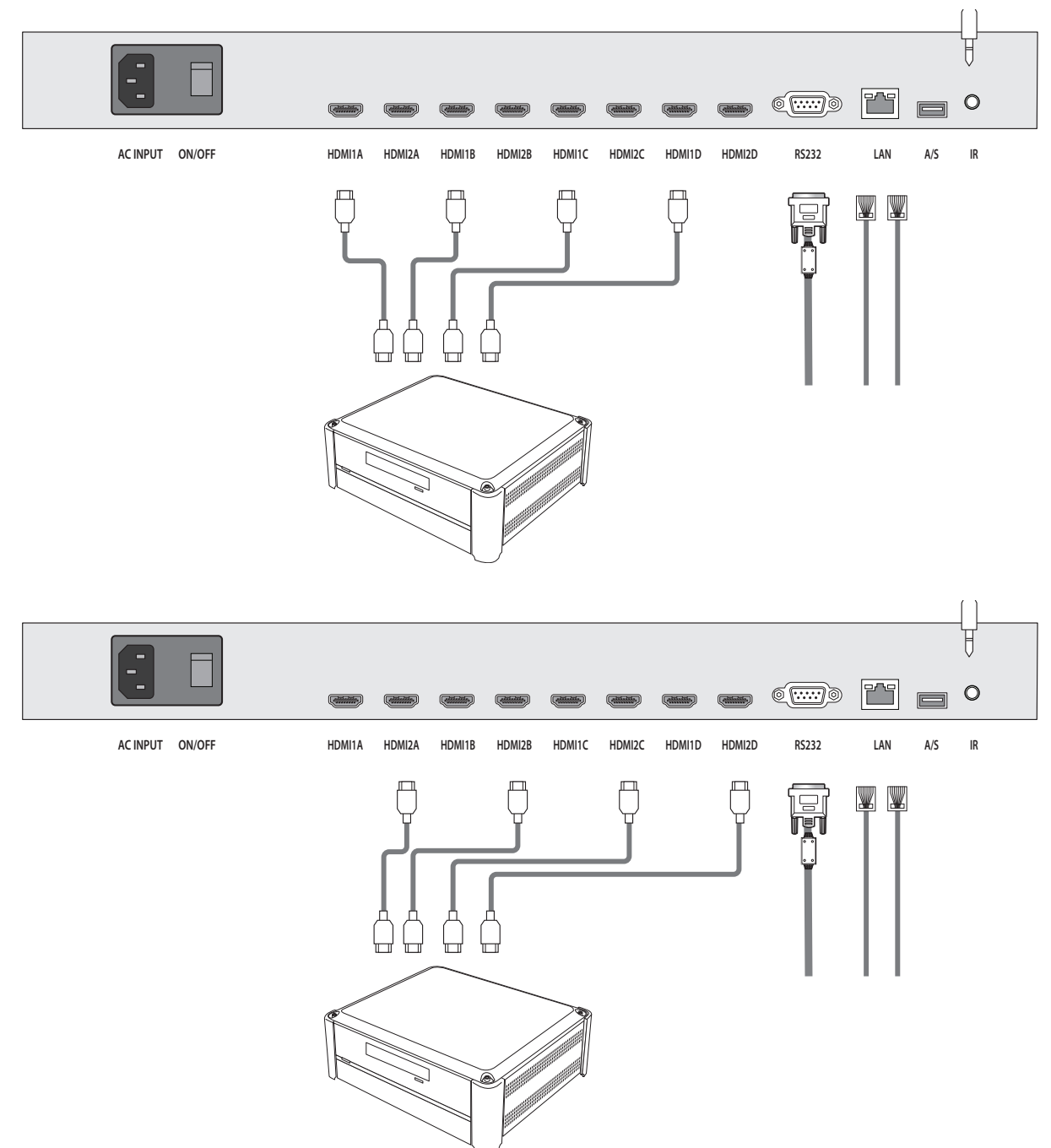

■ Display input selection

- The input mode of the display unit should be configured as described below.
- If the cable connection was made with the input group 1 (HDMI1A, HDMI1B, HDMI1C, HDMI1D), then press “Group 1-UHD” button in the remote controller. Press “Group 2-UHD” button for the input group 2 (HDMI2A, HDMI2B, HDMI2C, HDMI2D).

■ Graphic card configuration

- Compose one full screen image with 4 separate screens with the graphic configuration software provided by the graphic card makers.

• Please refer to the user guide of each graphic card maker or contact to the company for detailed usage of the graphic card.

- The configuration for the optional ORION PC is as follows.
- As you connect the output ports of the PC to the input ports in the display, you will see the following screen. However, the screen image may be different due to various cable connection or PC settings.

• In case you do not have the same screen image like following screen image, you still configure the display as described below.



- Click the right button of your mouse on the desktop to pop up the menu and select “Catalyst Control Center” (CCC).

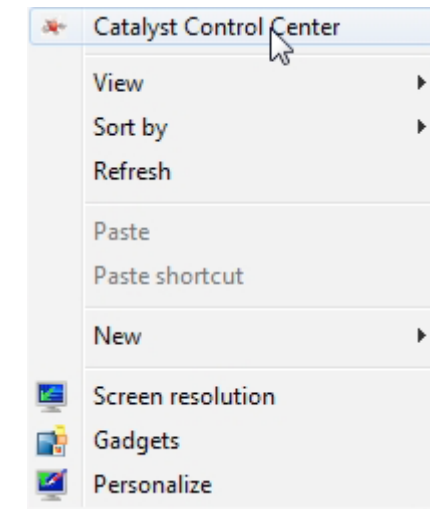

1. Duplicating Display

- Select “Creating and Arranging Desktops” from the menu bar on the left after executing CCC.
- The upper part of the “Creating and Arranging Desktops” window is “Desktop layout part” and the lower part is “Display selection Part.” The basic display No. 1, 2, 3 and 4 will be displayed as shown below. But, the layout may vary due to the cable connection.

• Following process is duplicating the display No. 2, 3, and 4 as the display No. 1. In case you do not have the same display layout like following screen image, you still duplicate the displays as described below.

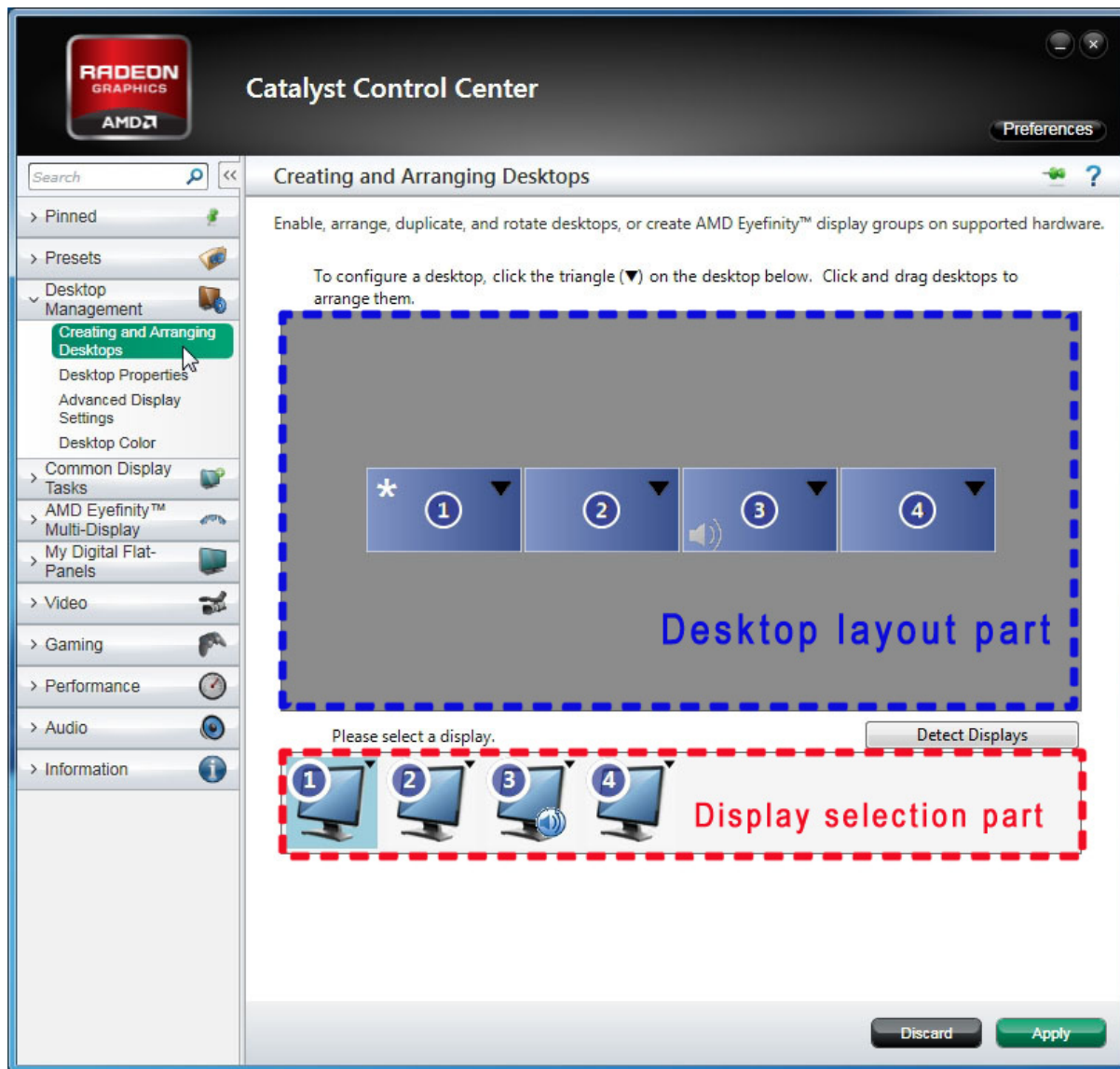

- Click the display No. 2 in the “Display selection part” with the right button of your mouse to popup the window and select “Duplicate.”



- When you see the message “Please select a desktop to duplicate” on the screen as shown below, select the display No. 1 in the “Desktop layout part.”

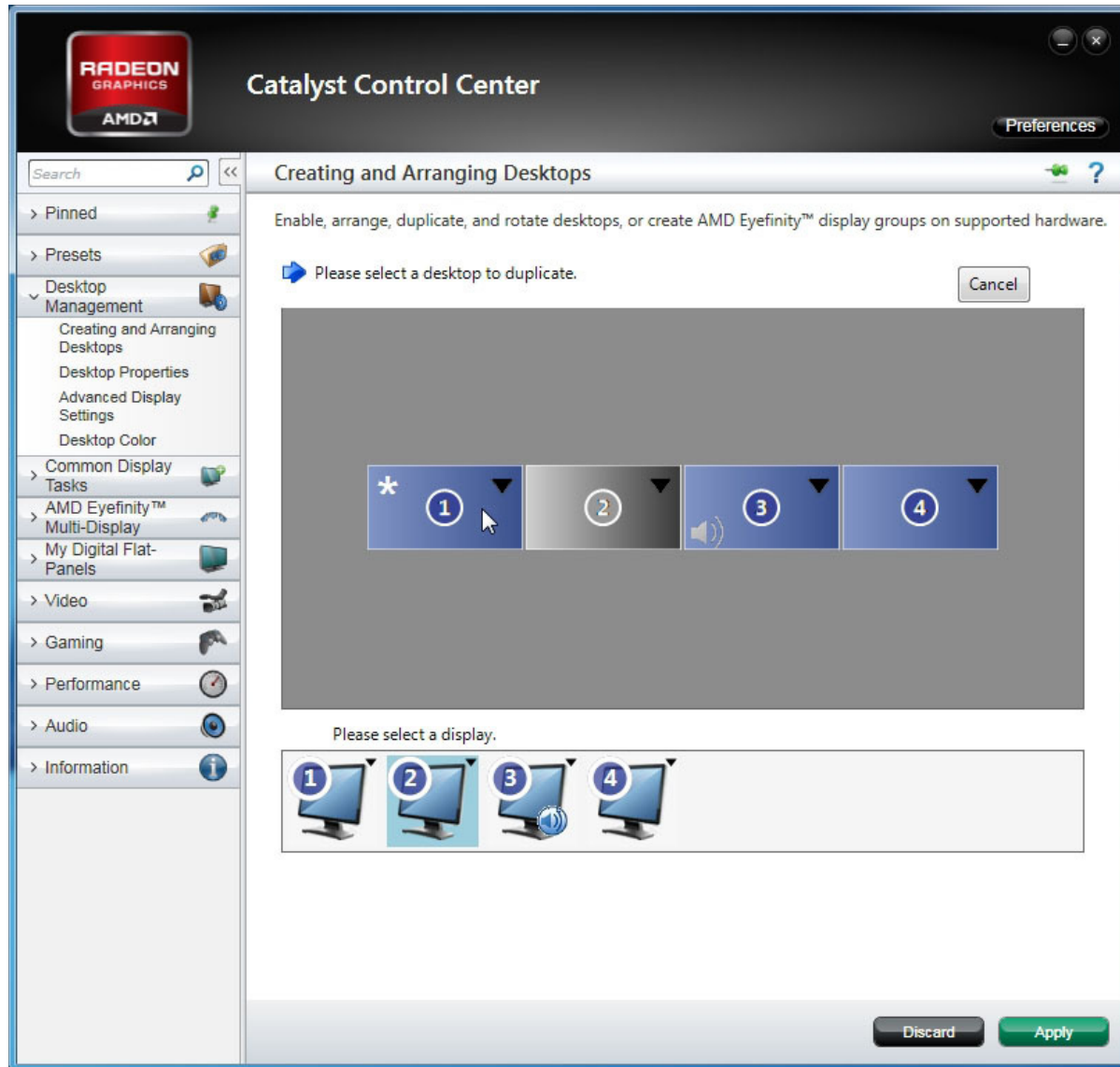

- Then you will see the following window for caution. Select “Continue”.

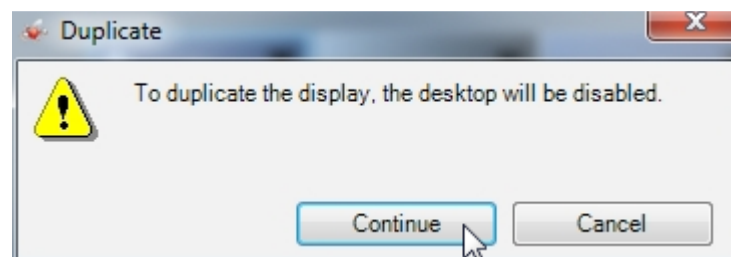

- The screen will be turned off for a moment and turned on.
- After the screen is turned on, the following caution window will be displayed. Then select “Yes”.

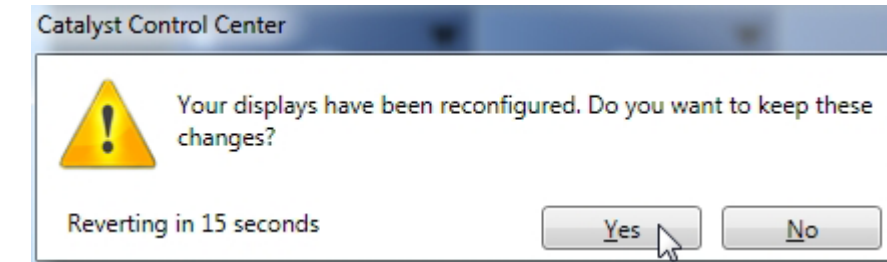

- Click the display No. 3 in the “Display selection part” with the right button of your mouse to popup the window and select “Duplicate.”

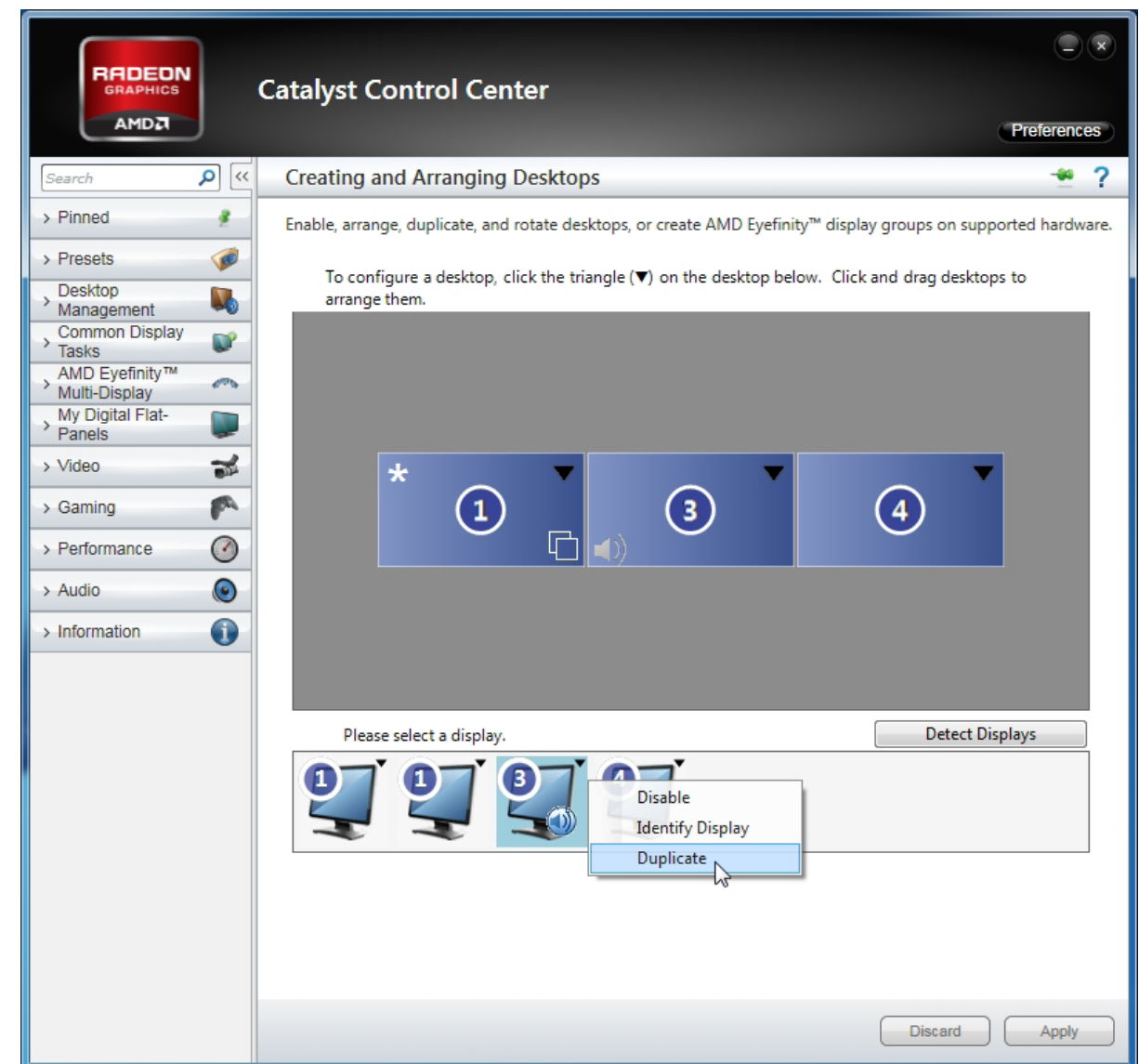

- When you see the message “Please select a desktop to duplicate” on the screen as shown below, select the display No. 1 in the “Desktop layout part.”

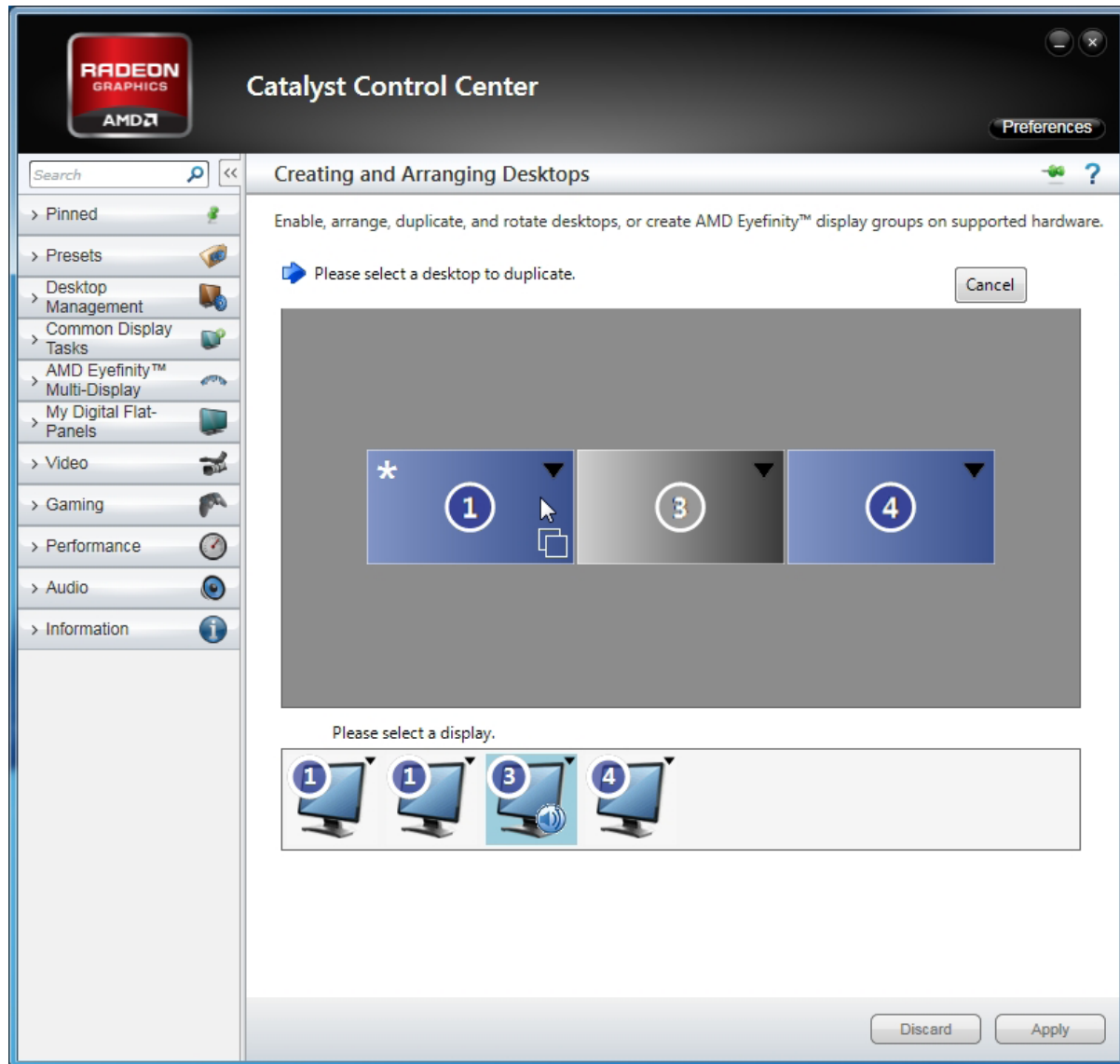

- Then you will see the following window for caution. Select “Continue”.

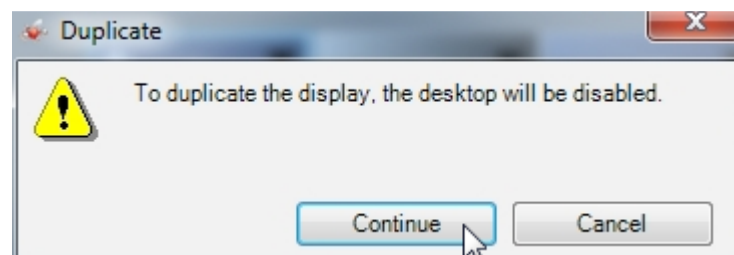

- The screen will be turned off for a moment and turned on.
- After the screen is turned on, the following caution window will be displayed. Then select “Yes”.

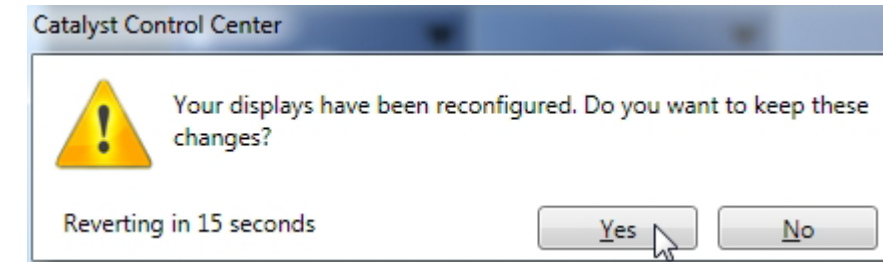

- Click the display No. 4 in the “Display selection part” with the right button of your mouse to popup the window and select “Duplicate.”



- Since the display No. 1 is left to duplicate, the window for selecting the display for duplication will not be popped up and the following caution window will be displayed. Then select "Continue"

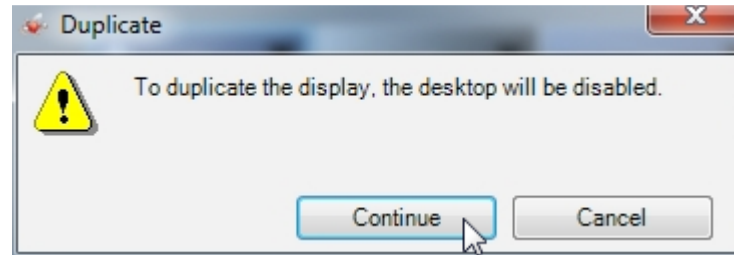

- The screen will be turned off for a moment and turned on.
- After the screen is turned on, the following caution window will be displayed. Then select "Yes".

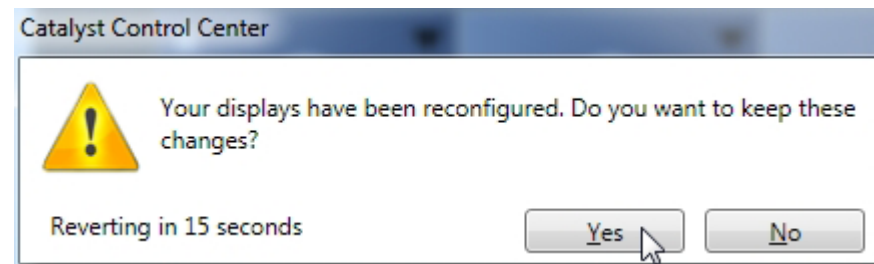

- All the displays are duplicated as the display No. 1.

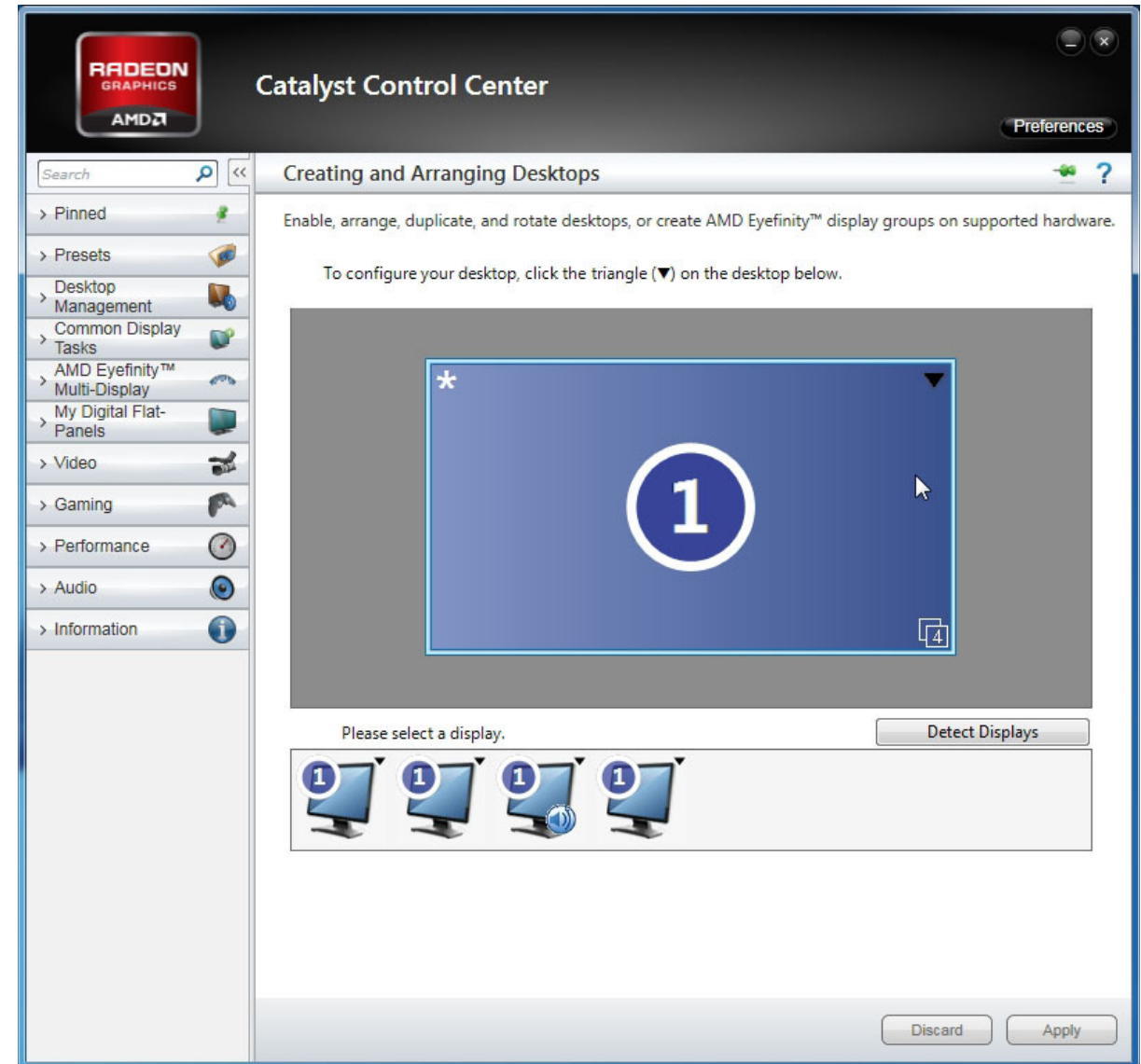

2. Eyefinity Configuration

- This is the Eyefinity configuration for combining the desktop as one screen.
- Click the right button of the mouse on the display No. 1 in the “Desktop layout part” for the popup menus and select “Display Group” - “Create Group”.

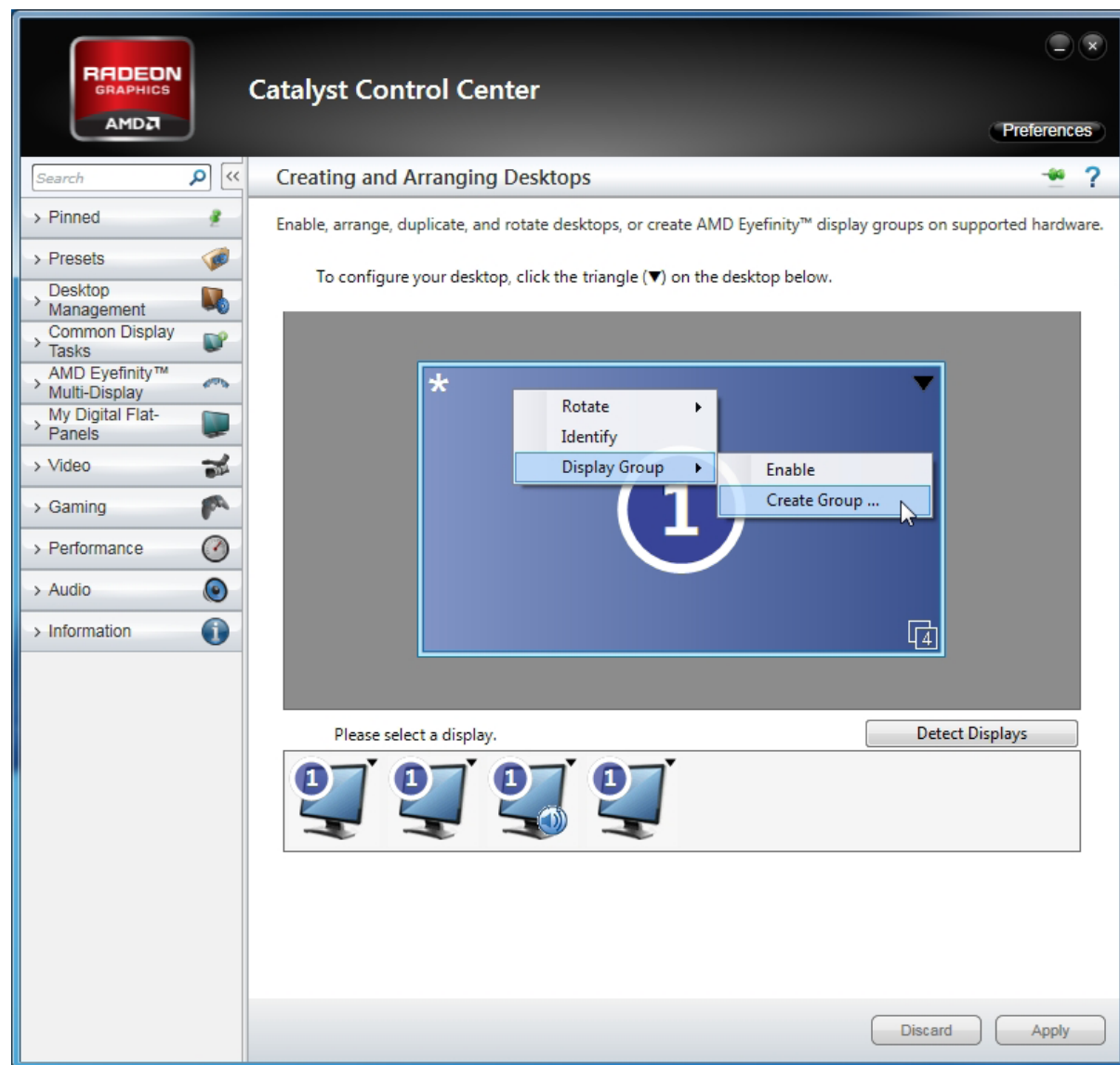

- Then you will have the window for selecting layout as shown below.
- You can select “4displays (4X1)” or “4displays (2X2).” Select “4displays (2X2)” and click “Accept.”

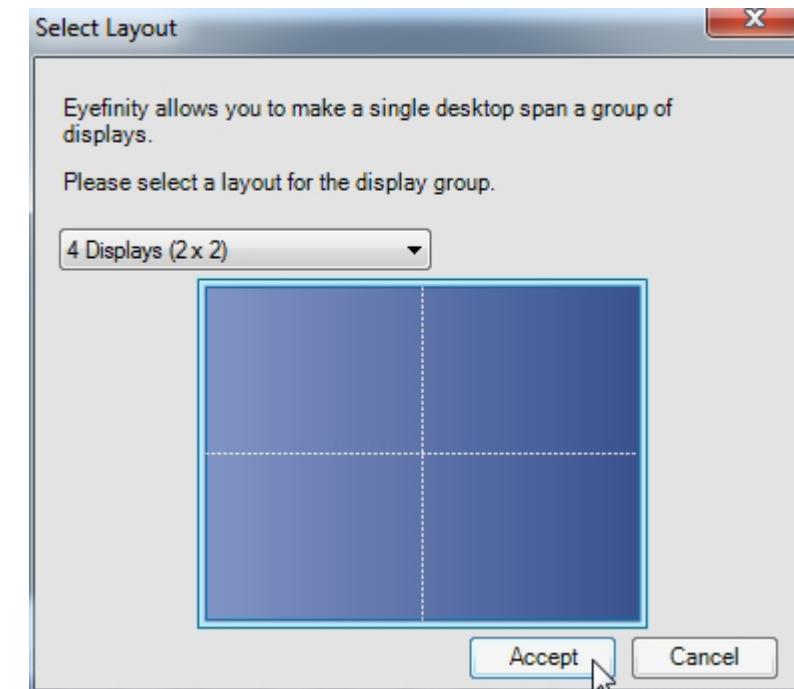

- The desktop is combined after the screen is turned off and on again. Check the arrangement whether the screens are arranged in an orderly manner.
- If it is correct, the desktop will be the following screen image.



- If it is not correct, the screen can be arranged in disorder as shown below. The following screen image is an example and the incorrect arrangement can be vary.



- Concurrently, CCC window will be displayed as shown below.
- If the arrangement is correct, select "Yes."
- Select "No" for incorrect.



- In case you select “No,” follow the display arrangement procedure as shown below.

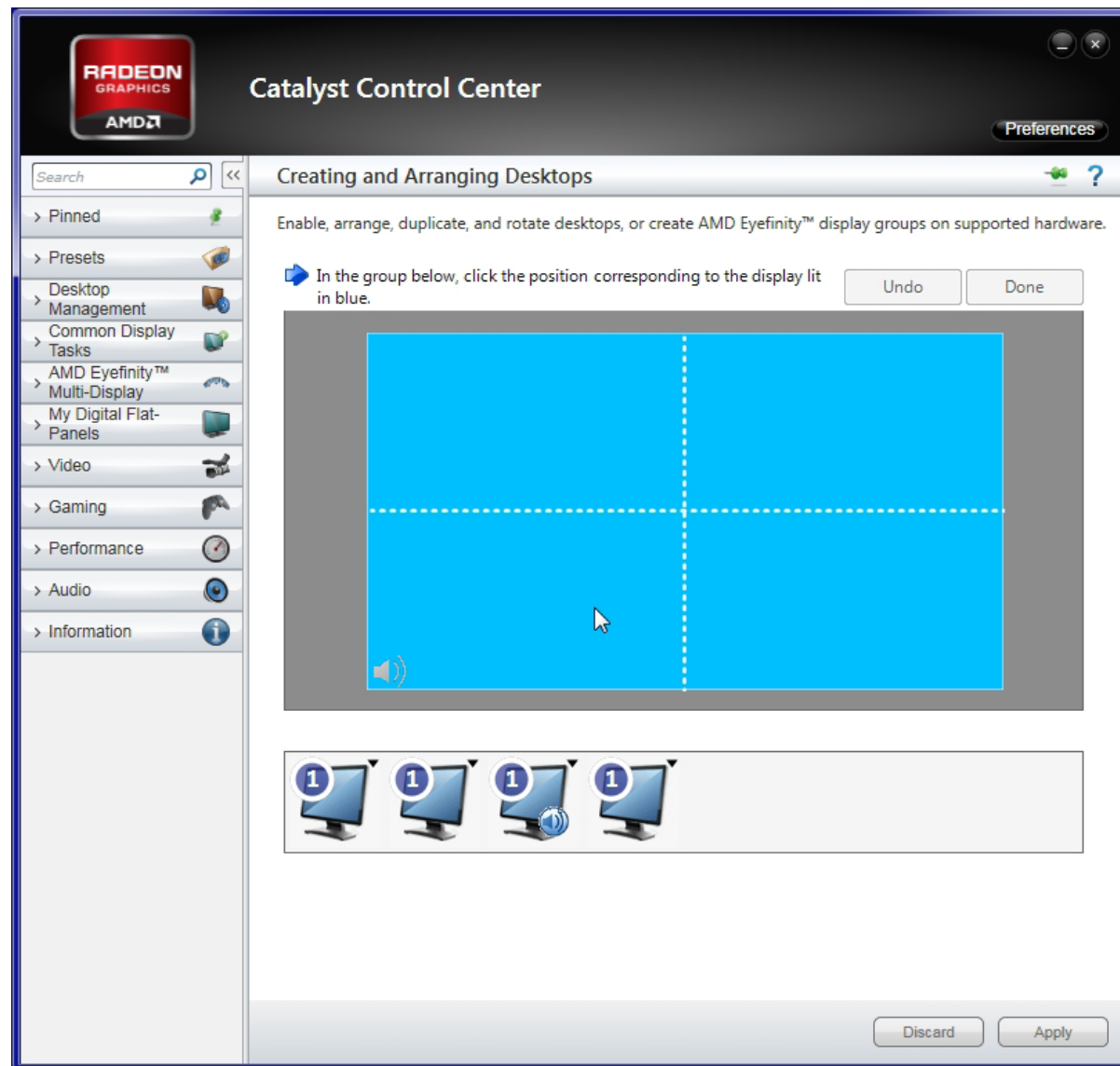

- Simultaneously, one of 4 displays is turned on with blue color.

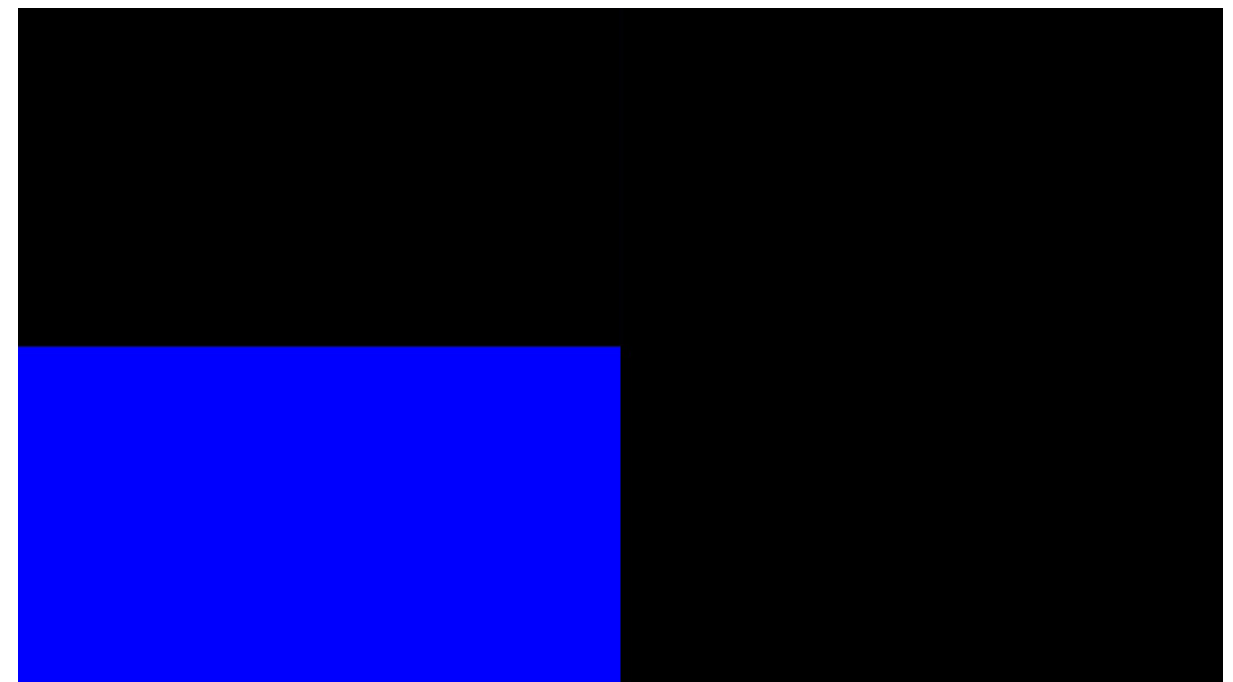

- Click the position of the display of blue color in the “Desktop layout part” in CCC.

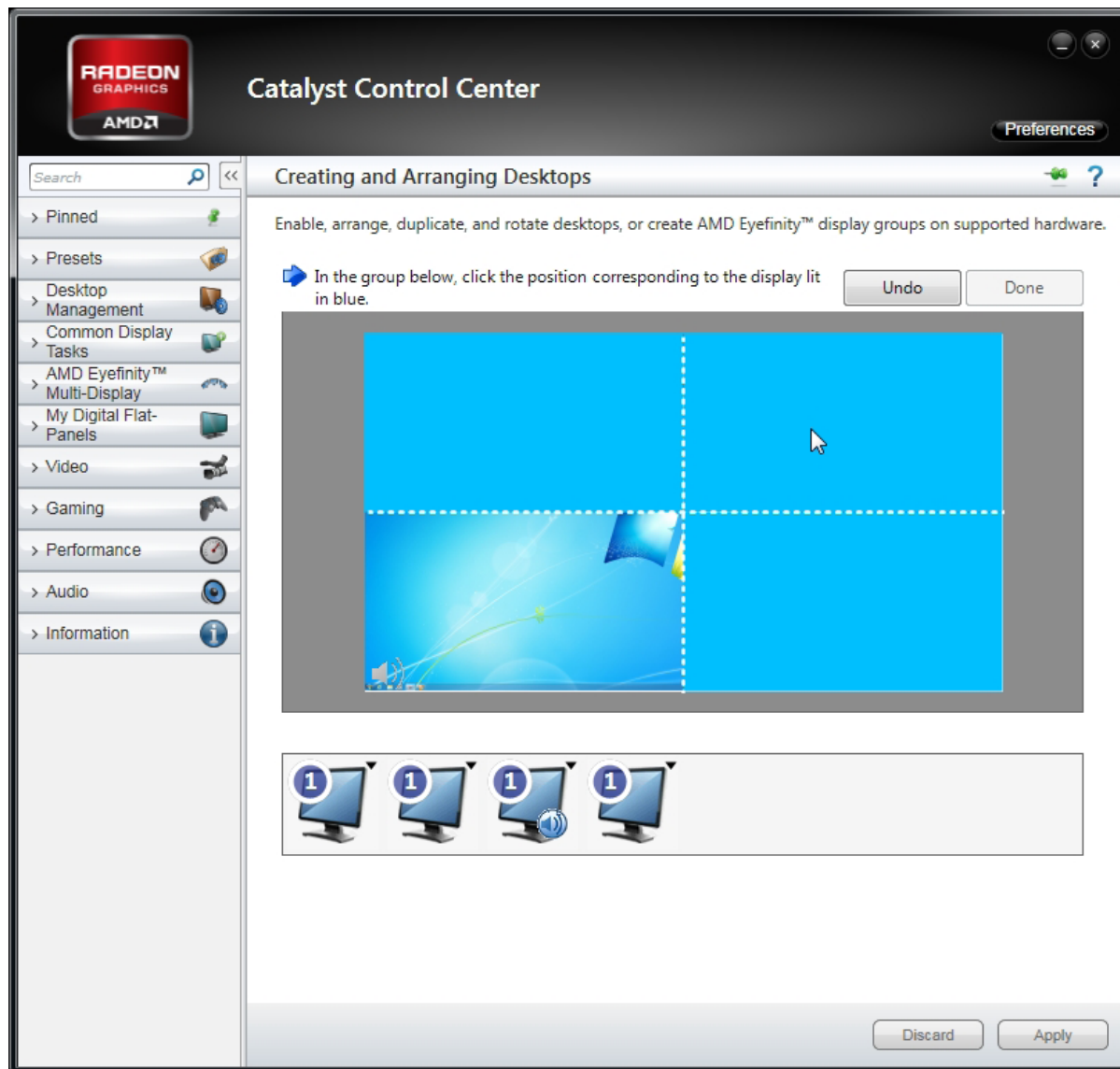

- When the display arrangement is completed and the screen is correctly displayed, click “Done.”



- Then the other one of 4 displays is turned on with blue color again. In the same manner, click the position of the display of blue color in the “Desktop layout part” in CCC again.

- The next procedure is “Bezel Compensation.” Since it is not a necessary procedure, click “No.”

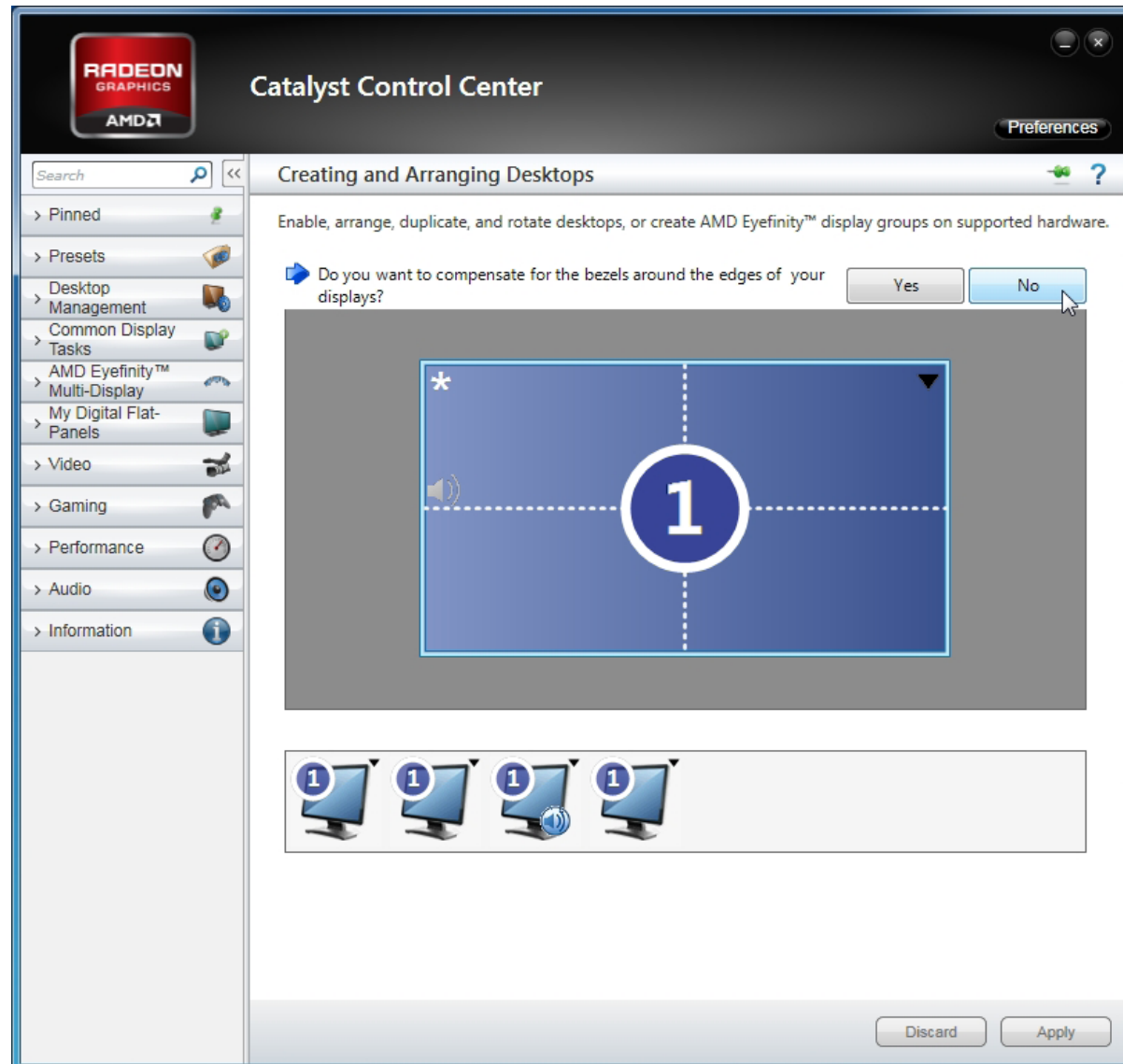

- Then all configurations for CCC are completed. The desktop with UHD resolution will be displayed as shown below.



08. PROTOCOL

Introduction

- This document contains the communication PROTOCOL between LCD and its control devices for better use.
- It focuses on the brief functional explanation and communication protocol without detailed technical matters.

1. Communication Setting

- Transmission type: Asynchronous Serial Communication
- Baud Rate: Select one rate among 9600bps, 14400bps, 19200bps, 38400bps, 57600bps, or 115200 bps
- Parity bit: None
- Stop bits: 1

2. Protocol Format

2.1. Send To LCD

STX	CMD	Ex CMD	Length	Data	ETX
1 byte	1 byte	1 byte	1 byte	Variable	1 byte

Group ID	Multi ID	Other Data
1 byte	1 byte	N byte

- It is a commanding format to LCD. The command will be effective only for the set of the designated ID.
- STX (0x02) : Code for initiation. It means the beginning of Protocol. (Fixed value)
- CMD: Code for actual command. (Variable)
- Ex CMD: Code for expanded code. (Fixed value 0x01)
- Length: The length of "Data" area. (Variable: 0~255)
- Data: The areas for "ID" and the other Data (Variable)
- Group / Multi ID: Code for distinguishing LCD sets. Group ID : 0x01 / Multi ID : 0x01 (Fixed).
- ETX(0x03) : Code for the end of Protocol (Fixed value)

2.2. Receive From LCD

STX	CMD	Ex CMD	Length	Data	Check Sum	ETX
1 byte	1 byte	1 byte	1 byte	Variable	1 byte	1 byte

Group ID	Multi ID	Other Data
1 byte	1 byte	N byte

- Response format to a certain command from the designated set among LCD sets. The difference from "Send to LCD" is "Check sum".
- STX(0x02) : Code for initiation. It means the beginning of Protocol. (Fixed value)
- CMD: Code for actual command. (Variable)
- Ex CMD: Code for expanded code. (Fixed value 0x01)
- Length: The length of "Data" area. (Variable: 0~255)
- Data: The areas for "ID" and the other Data (Variable)
- ID: Code for distinguishing LCD sets. Group ID : 0x01 / Multi ID : 0x01 (Fixed).
- Check sum: Execute "Not" operation after adding all the values in "STX~Data" area.
- ETX(0x03): The end of the code. (Fixed value)

Communication Sequence

- Wait for 50msec for response after sending the command. If there is no response, it is recommended to resend the command.
- Do not send the other command or change input resolution during command transmission.



3. Basic Command

3.1. Status

- This is the command for checking the current status of LCD.
- It is available only during Power On status.
- CMD : 0x87
- Send To LCD

Value	STX	CMD	Ex CMD	Length	Data			ETX
	0x02	0x87	0x01	0x03	Group ID	Multi ID	Mode	
	0x02	0x87	0x01	0x03	Variable	Variable	Variable	0x03

*Group ID/Multi ID Range (Program) : Group ID : 0x01 / Multi ID : 0x01 Fixed
 *Mode : Read(Get) - 0x00(0)

Receive From LCD

Value	STX	CMD	Ex CMD	Length	Data				Check Sum	ETX
	0x02	0x87	0x01	0x1C	Group ID	Multi ID	Mode	Status		
	0x02	0x87	0x01	0x1C	Variable	Variable	Variable	Variable	0x03

*Group ID/Multi ID Range (Program) : Group ID : 0x01 / Multi ID : 0x01 Fixed
 *Mode : Read(Get) - 0x00(0)

*Check Sum: Execute "Not" operation after adding all the values in "STX~Data" area.

Status (25 Byte)

No.	Data	Length	Explanation
1	Display Model	10 Byte	Ex) OLS-8410NL 0x4F 0x4C 0x53 0x2D 0x38 0x34 0x31 0x30 0x4E 0x4C
2	Firmware Version	10 Byte	Ex) 0.80.01A.O 0x00 0x2E 0x38 0x30 0x2E 0x30 0x31 0x41 0x2E 0x4F
3	IP Address	4 Byte	Ex) 192.168.00.04 0xC0 0xA8 0x00 0x04
4	Input Source	1 Byte	0x11: HDMI 1A, 0x12: HDMI 1B, 0x13: HDMI 1C, 0x14: HDMI 1D, 0x15: HDMI 2A, 0x16: HDMI 2B, 0x17: HDMI 2C, 0x18: HDMI 2D, 0x31: UHD 1, 0x32: UHD 2

3.2. Power On/Off

- Power On/Off
- Power On command is available only during Power Off (Stand-by) status.
- Power Off command is available only during Power On (Operative) status.
- CMD : 0x10

- **Send To LCD**

	STX	CMD	Ex CMD	Length	Data				ETX
					Group ID	Multi ID	Mode	Control	
Value	0x02	0x10	0x01	0x04	Variable	Variable	Variable	Variable	0x03

*Group ID/Multi ID range(Program) : Group ID : 0x01 / Multi ID : 0x01 Fixed
 *Mode : Read(Get) – 0x00(0) , Write(Set) – 0x02(2)
 *Control : Power Off – 0x00(0) , Power On – 0x01(1)

- **Receive From LCD**

	STX	CMD	Ex CMD	Length	Data				Check Sum	ETX
					Group ID	Multi ID	Mode	Control		
Value	0x02	0x10	0x01	0x04	Variable	Variable	Variable	Variable	0x03	

*Group ID/Multi ID range(Program) : Group ID : 0x01 / Multi ID : 0x01 Fixed
 *Mode : Read(Get)Response – 0x00(0) , Write(Set)Response – 0x02(2)
 *Control : Power Off – 0x00(0) , Power On – 0x01(1)
 *Check Sum: Execute "Not" operation after adding all the values in "STX~Data" area.

3.3. Input Source

- This is the command for changing the input source.
- This command is available while power is on.
- CMD : 0xD1

- **Send To LCD**

	STX	CMD	Ex CMD	Length	Data				ETX
					Group ID	Multi ID	Mode	Input Source	
Value	0x02	0xD1	0x01	0x04	Variable	Variable	Variable	Variable	0x03

*Group ID/Multi ID range(Program) : Group ID : 0x01 / Multi ID : 0x01 Fixed
 *Mode : Read(Get) – 0x00(0) , Write(Set) – 0x02(2)
 *Input Source : 0x11(HDMI1A), 0x12(HDMI1B), 0x13(HDMI1C), 0x14(HDMI1D), 0x15(HDMI2A), 0x16(HDMI2B), 0x17(HDMI2C), 0x18(HDMI2D), 0x31(UHD 1), 0x32(UHD 2)

- **Receive From LCD**

	STX	CMD	Ex CMD	Length	Data				Check Sum	ETX
					Group ID	Multi ID	Mode	Control		
Value	0x02	0xD1	0x01	0x04	Variable	Variable	Variable	Variable	0x03	

*Group ID/Multi ID range(Program) : Group ID : 0x01 / Multi ID : 0x01 Fixed
 *Mode : Read(Get)Response – 0x00(0) , Write(Set)Response – 0x02(2)
 *Input Source : 0x11(HDMI1A), 0x12(HDMI1B), 0x13(HDMI1C), 0x14(HDMI1D), 0x15(HDMI2A), 0x16(HDMI2B), 0x17(HDMI2C), 0x18(HDMI2D), 0x31(UHD 1), 0x32(UHD 2)
 *Check Sum: Execute "Not" operation after adding all the values in "STX~Data" area.

3.4. Information

- It is the command for displaying the information of LCD set status.
- It is available only during Power On (Operative) status.
- CMD : 0x1A

- **Send To LCD**

	STX	CMD	Ex CMD	Length	Data			ETX
					Group ID	Multi ID	Mode	
Value	0x02	0x1A	0x01	0x03	Variable	Variable	Variable	0x03

*Group/Multi ID Range(Program) : Group ID : 0x01 / Multi ID : 0x01 Fixed
 *Mode : Write(Set) – 0x02

- **Receive From LCD**

	STX	CMD	Ex CMD	Length	Data			Check Sum	ETX
					Group ID	Multi ID	Mode		
Value	0x02	0x1A	0x01	0x03	Variable	Variable	Variable	0x03	

*Group ID/Multi ID range(Program) : Group ID : 0x01 / Multi ID : 0x01 Fixed
 *Mode : Write(Set)Response – 0x02(2)
 *Check Sum: Execute "Not" operation after adding all the values in "STX~Data" area.

4. Picture Control Command

4.1. Brightness Control

- This is the command to adjust the overall image and background brightness.
- It is available only on Power On (Operative) status.
- The adjusted value cannot be applied for Stand-By or No input status. So, it can be applied when LCD is in operating condition with the input signal.
- CMD : 0x20

- **Send To LCD**

	STX	CMD	Ex CMD	Length	Data				ETX
					Group ID	Multi ID	Mode	Control	
Value	0x02	0x20	0x01	0x04	Variable	Variable	Variable	Variable	0x03

*Group ID/Multi ID range(Program) : Group ID : 0x01 / Multi ID : 0x01 Fixed
 *Mode : Read(Get) – 0x00(0) , Write(Set) – 0x02(2)
 *Control : 0x00(0) ~ 0x64(100)

- **Receive From LCD**

	STX	CMD	Ex CMD	Length	Data				Check Sum	ETX
					Group ID	Multi ID	Mode	Control		
Value	0x02	0x20	0x01	0x04	Variable	Variable	Variable	Variable	0x03	

*Group ID/Multi ID range(Program) : Group ID : 0x01 / Multi ID : 0x01 Fixed
 *Mode : Read(Get)Response – 0x00(0) , Write(Set)Response – 0x02(2)
 *Control : 0x00(0)~0x64(100)
 *Check Sum: Execute "Not" operation after adding all the values in "STX~Data" area.

4.2. Contrast Control

- This is the command to adjust the image brightness in relationship to the background.
- It is available only on Power On (Operative) status.
- The adjusted value cannot be applied for Stand-By or No input status. So, it can be applied when LCD is in operating condition with the input signal.
- CMD : 0x21

- **Send To LCD**

	STX	CMD	Ex CMD	Length	Data				ETX
					Group ID	Multi ID	Mode	Control	
Value	0x02	0x21	0x01	0x04	Variable	Variable	Variable	Variable	0x03

*Group ID/Multi ID range(Program) : Group ID : 0x01 / Multi ID : 0x01 Fixed
 *Mode : Read(Get) – 0x00(0) , Write(Set) – 0x02(2)
 *Control : 0x00(0) ~ 0x64(100)

- Receive From LCD

	STX	CMD	Ex CMD	Length	Data				Check Sum	ETX
					Group ID	Multi ID	Mode	Control		
Value	0x02	0x21	0x01	0x04	Variable	Variable	Variable	Variable	Variable	0x03

*Group ID/Multi ID range(Program) : Group ID : 0x01 / Multi ID : 0x01 Fixed
 *Mode : Read(Get)Response – 0x00(0), Write(Set)Response – 0x02(2)
 *Control : 0x00(0) ~ 0x64(100)
 *Check Sum: Execute "Not" operation after adding all the values in "STX~Data" area.

4.3. Color Control

- This is the command to adjust the color depth of the screen.
- It is available only on Power On (Operative) status.
- CMD : 0x25

- Send To LCD

	STX	CMD	Ex CMD	Length	Data				ETX
					Group ID	Multi ID	Mode	Control	
Value	0x02	0x25	0x01	0x04	Variable	Variable	Variable	Variable	0x03

*Group ID/Multi ID range(Program) : Group ID : 0x01 / Multi ID : 0x01 Fixed
 *Mode : Read(Get) – 0x00(0) , Write(Set) – 0x02(2)
 *Control : 0x00(0) ~ 0x64(100)

- Receive From LCD

	STX	CMD	Ex CMD	Length	Data				Check Sum	ETX
					Group ID	Multi ID	Mode	Control		
Value	0x02	0x25	0x01	0x04	Variable	Variable	Variable	Variable	Variable	0x03

*Group ID/Multi ID range(Program) : Group ID : 0x01 / Multi ID : 0x01 Fixed
 *Mode : Read(Get)Response – 0x00(0), Write(Set)Response – 0x02(2)
 *Control : 0x00(0) ~ 0x64(100)
 *Check Sum: Execute "Not" operation after adding all the values in "STX~Data" area.

4.4. Tint Control

- This is the command to adjust the tint of the screen.
- It is available only on Power On (Operative) status.
- The adjusted value cannot be applied for Stand-By or No input status. So, it can be applied when LCD is in operating condition with the input signal.
- CMD : 0x24

- Send To LCD

	STX	CMD	Ex CMD	Length	Data				ETX
					Group ID	Multi ID	Mode	Control	
Value	0x02	0x24	0x01	0x04	Variable	Variable	Variable	Variable	0x03

*Group ID/Multi ID range(Program) : Group ID : 0x01 / Multi ID : 0x01 Fixed
 *Mode : Read(Get) – 0x00(0) , Write(Set) – 0x02(2)
 *Control : 0x00(0) ~ 0x64(100)

- Receive From LCD

	STX	CMD	Ex CMD	Length	Data				Check Sum	ETX
					Group ID	Multi ID	Mode	Control		
Value	0x02	0x24	0x01	0x04	Variable	Variable	Variable	Variable	Variable	0x03

*Group ID/Multi ID range(Program) : Group ID : 0x01 / Multi ID : 0x01 Fixed

*Mode : Read(Get)Response – 0x00(0), Write(Set)Response – 0x02(2)
 *Control : 0x00(0) ~ 0x64(100)
 *Check Sum: Execute "Not" operation after adding all the values in "STX~Data" area.

4.5. Video Mode(Color Temperature Mode)

- This is command to adjust the color temperature of the entire screen. A WARM(6500K) will make the screen reddish. A COOL(1000K) will make the screen bluish. A Natural is the color temperature of the typical panel without any adjustment. A Polycom is the requested color temperature of buyer. If COLOR TEMPERATURE needs further adjustment, CUSTOM must be showing as the Video Mode selection.
- Color temperature is 8000K for Polycom mode, 10000K for Cool mode and 6500K for Warm mode. Natural Mode is the color temperature of the typical panel without any adjustment. User can control the color temperature with Custom mode.
- It is available only on Power On (Operative) status.
- The adjusted value cannot be applied for Stand-By or No input status. So, it can be applied when LCD is in operating condition with the input signal.
- CMD : 0x26

- Send To LCD

	STX	CMD	Ex CMD	Length	Data				ETX
					Group ID	Multi ID	Mode	Control	
Value	0x02	0x26	0x01	0x04	Variable	Variable	Variable	Variable	0x03

*Group ID/Multi ID range(Program) : Group ID : 0x01 / Multi ID : 0x01 Fixed
 *Mode : Read(Get) – 0x00(0) , Write(Set) – 0x02(2)
 *Control : Polycom(0x01), Cool(0x02), Normal(0x03), Warm(0x04), Custom(0x05)

- Receive From LCD

	STX	CMD	Ex CMD	Length	Data				Check Sum	ETX
					Group ID	Multi ID	Mode	Control		
Value	0x02	0x26	0x01	0x04	Variable	Variable	Variable	Variable	Variable	0x03

*Group ID/Multi ID range(Program) : Group ID : 0x01 / Multi ID : 0x01 Fixed
 *Mode : Read(Get)Response – 0x00(0), Write(Set)Response – 0x02(2)
 *Control : TBD
 *Check Sum: Execute "Not" operation after adding all the values in "STX~Data" area.

5. Screen Adjustment Command

5.1. H Position

- This is the command to control the horizontal position of the image within the Display area of the LCD.
- CMD : 0x36

- Send To LCD

	STX	CMD	Ex CMD	Length	Data				ETX
					Group ID	Multi ID	Mode	Control	
Value	0x02	0x36	0x01	0x04	Variable	Variable	Variable	Variable	0x03

*Group ID/Multi ID range(Program) : Group ID : 0x01 / Multi ID : 0x01 Fixed
 *Mode : Read(Get) – 0x00(0), Write(Set) – 0x02(2)
 *Control Value : 0x00(0)~0x64(100)

- Receive From LCD

	STX	CMD	Ex CMD	Length	Data				Check Sum	ETX
					Group ID	Multi ID	Mode	Control		
Value	0x02	0x36	0x01	0x04	Variable	Variable	Variable	Variable	Variable	0x03

*Group ID/Multi ID range(Program) : Group ID : 0x01 / Multi ID : 0x01 Fixed
 *Mode : Read(Get)Response – 0x00(0), Write(Set)Response – 0x02(2)

*Control Value : 0x00(0)~0x64(100)

*Check Sum: Execute "Not" operation after adding all the values in "STX~Data" area.

5.2. V Position

- This is the command to control the vertical position of the image within the Display area of the LCD.

- CMD : 0x37

- Send To LCD

	STX	CMD	Ex CMD	Length	Data				ETX
					Group ID	Multi ID	Mode	Control	
Value	0x02	0x37	0x01	0x04	Variable	Variable	Variable	Variable	0x03

*Group ID/Multi ID range(Program) : Group ID : 0x01 / Multi ID : 0x01 Fixed

*Mode : Read(Get) – 0x00(0), Write(Set) – 0x02(2)

*Control Value : 0x00(0)~0x64(100)

- Receive From LCD

	STX	CMD	Ex CMD	Length	Data				Check Sum	ETX
					Group ID	Multi ID	Mode	Control		
Value	0x02	0x37	0x01	0x04	Variable	Variable	Variable	Variable	0x03	

*Group ID/Multi ID range(Program) : Group ID : 0x01 / Multi ID : 0x01 Fixed

*Mode : Read(Get)Response – 0x00(0), Write(Set)Response – 0x02(2)

*Control Value : 0x00(0)~0x64(100)

*Check Sum: Execute "Not" operation after adding all the values in "STX~Data" area.

5.3. Aspect Ratio

- Aspect ratio can be selected or changed to 16:9 or 4:3.

- CMD : 0xB6

- Send To LCD

	STX	CMD	Ex CMD	Length	Data				ETX
					Group ID	Multi ID	Mode	Control	
Value	0x02	0xB6	0x01	0x04	Variable	Variable	Variable	Variable	0x03

*Group ID/Multi ID range(Program) : Group ID : 0x01 / Multi ID : 0x01 Fixed

*Mode : Read(Get) – 0x00(0), Write(Set) – 0x02(2)

*Control Value: 0x01(1) for 16:9, 0x02(2) for 4:3.

- Receive From LCD

	STX	CMD	Ex CMD	Length	Data				Check Sum	ETX
					Group ID	Multi ID	Mode	Control		
Value	0x02	0xB6	0x01	0x04	Variable	Variable	Variable	Variable	0x03	

*Group ID/Multi ID range(Program) : Group ID : 0x01 / Multi ID : 0x01 Fixed

*Mode : Read(Get)Response – 0x00(0), Write(Set)Response – 0x02(2)

*Control Value: 0x01(1) for 16:9, 0x02(2) for 4:3.

*Check Sum: Execute "Not" operation after adding all the values in "STX~Data" area.

5.4. Video Mute

- It is the command for selecting Video Mute.

- User can select blank screen.

- CMD : 0xB7

- Send To LCD

	STX	CMD	Ex CMD	Length	Data				ETX
					Group ID	Multi ID	Mode	Control	
Value	0x02	0xB7	0x01	0x04	Variable	Variable	Variable	Variable	0x03

*Group ID/Multi ID range(Program) : Group ID : 0x01 / Multi ID : 0x01 Fixed

*Mode : Read(Get) – 0x00(0), Write(Set) – 0x02(2)

*Control : Blank – 0x00(0), Unblank – 0x01(1)

- Receive From LCD

	STX	CMD	Ex CMD	Length	Data				Check Sum	ETX
					Group ID	Multi ID	Mode	Control		
Value	0x02	0xB7	0x01	0x04	Variable	Variable	Variable	Variable	0x03	

*Group ID/Multi ID range(Program) : Group ID : 0x01 / Multi ID : 0x01 Fixed

*Mode : Read(Get)Response – 0x00(0), Write(Set)Response – 0x02(2)

*Control : Blank – 0x00(0), Unblank – 0x01(1)

*Check Sum: Execute "Not" operation after adding all the values in "STX~Data" area.

5.5. Get Screen Control Data

- Get the adjusted data for Horizontal and Vertical Position, Aspect Ratio, Video Mute(Blank, Unblank), and Panel Key Lock(Key Lock, Unlock)

- CMD : 0x93

- Send To LCD

	STX	CMD	Ex CMD	Length	Data			ETX
					Group ID	Multi ID	Mode	
Value	0x02	0x93	0x01	0x03	Variable	Variable	Variable	0x03

*Group ID/Multi ID range(Program) : Group ID : 0x01 / Multi ID : 0x01 Fixed

*Mode : Read(Get) – 0x00(0)

- Receive From LCD

	STX	CMD	Ex CMD	Length	Data				Check Sum	ETX
					Group ID	Multi ID	Mode	Control		
Value	0x02	0x93	0x01	0x08	Variable	Variable	Variable	Variable	Variable	0x03

	H Position (1Byte)	V Position (1Byte)	Aspect Ratio (1Byte)	Video Mute (1Byte)	Panel Key Lock (1Byte)
Value	Variable	Variable	Variable	Variable	Variable

*Group ID/Multi ID range(Program) : Group ID : 0x01 / Multi ID : 0x01 Fixed

*Mode : Read(Get)Response – 0x00(0)

*Control: each data is 1 Byte and the ranges of H Position is 0(0x00)~100(0x64), V Position is 0(0x00)~100(0x64).

For the Aspect Ratio, 1(0x01) is 16:9 and 2(0x02) is 4:3.

For the Video Mute, 0(0x00) is Blank and 1(0x01) is Unblank.

For the Panel Key Lock, 0(0x00) is Unlock, 1(0x01) is Key Lock

*Check Sum: Execute "Not" operation after adding all the values in "STX~Data" area.

6. SETUP A Command

6.1. Auto Power

- This is the command for selecting or deselecting Automatic Power On.

- CMD : 0x64

- **Send To LCD**

	STX	CMD	Ex CMD	Length	Data				ETX
					Group ID	Multi ID	Mode	Control	
Value	0x02	0x64	0x01	0x04	Variable	Variable	Variable	Variable	0x03

*Group/Multi ID Range(Program) : Group ID : 0x01 / Multi ID : 0x01 Fixed
 *Mode : Read(Get) – 0x00(0) , Write(Set) – 0x02(2)
 *Control : Deselect Auto Power On – 0x00(0), Select Auto Power On – 0x01(1)

- **Receive From LCD**

	STX	CMD	Ex CMD	Length	Data				Check Sum	ETX
					Group ID	Multi ID	Mode	Control		
Value	0x02	0x64	0x01	0x04	Variable	Variable	Variable	Variable	Variable	0x03

*Group ID/Multi ID range(Program) : Group ID : 0x01 / Multi ID : 0x01 Fixed
 *Mode : Read(Get)Response – 0x00(0), Write(Set)Response – 0x02(2)
 *Control : Deselect Auto Power On – 0x00(0), Select Auto Power On – 0x01(1)
 *Check Sum: Execute "Not" operation after adding all the values in "STX~Data" area.

6.2. Get Display Model

- This is the command for getting display information.
- It is available only during Power On (Operative) status.
- CMD : 0xB9

- **Send To LCD**

	STX	CMD	Ex CMD	Length	Data			ETX
					Group ID	Multi ID	Mode	
Value	0x02	0xB9	0x01	0x03	Variable	Variable	Variable	0x03

*Group ID/Multi ID range(Program) : Group ID : 0x01 / Multi ID : 0x01 Fixed
 *Mode : Read(Get) – 0x00(0)

- **Receive From LCD**

	STX	CMD	Ex CMD	Length	Data				Check Sum	ETX
					Group ID	Multi ID	Mode	Control (23Bytes)		
Value	0x02	0xB9	0x01	0x1A	Variable	Variable	Variable	Variable	0x03

*Group ID/Multi ID range(Program) : Group ID : 0x01 / Multi ID : 0x01 Fixed
 *Mode : Read(Get)Response – 0x00(0)
 *Control Value : <Model Name> 10 characters, It is displayed as ASCII value.
 Ex) OLS-8410NL : 0x4F 0x4C 0x53 0x2D 0x38 0x34 0x31 0x30 0x4E 0x4C ,
 <Serial Num> 13 Characters, The range of the each character is 0x00(0)~0x09(9).
 *Check Sum: Execute "Not" operation after adding all the values in "STX~Data" area.

6.3. Get Firmware Version

- This is the command for getting firmware version information.
- It is available only during Power On (Operative) status.
- CMD : 0xF9

- **Send To LCD**

	STX	CMD	Ex CMD	Length	Data			ETX
					Group ID	Multi ID	Mode	
Value	0x02	0xF9	0x01	0x03	Variable	Variable	Variable	0x03

*Group ID/Multi ID range(Program) : Group ID : 0x01 / Multi ID : 0x01 Fixed
 *Mode : Read(Get) – 0x00(0)

- **Receive From LCD**

	STX	CMD	Ex CMD	Length	Data				Check Sum	ETX
					Group ID	Multi ID	Mode	Version (20Bytes)		
Value	0x02	0xF9	0x01	0x17	Variable	Variable	Variable	Variable	0x03

*Group ID/Multi ID range(Program) : Group ID : 0x01 / Multi ID : 0x01 Fixed
 *Mode : Read(Get)Response – 0x00(0)
 *Version : e.g.) 0.80.01A.O20121116BT (20 Byte)

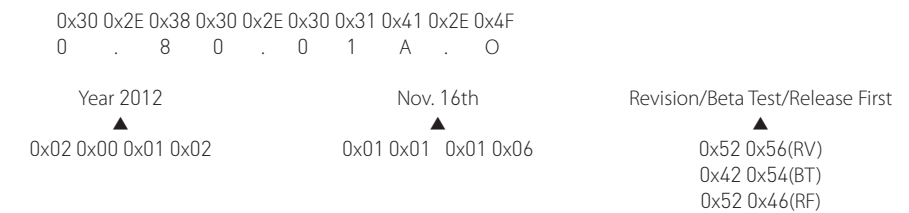

*Check Sum: Execute "Not" operation after adding all the values in "STX~Data" area.

6.4. DHCP

- This is the command for selecting or deselecting automatic Network IP configuration.
- CMD : 0x73

- **Send To LCD**

	STX	CMD	Ex CMD	Length	Data				ETX
					Group ID	Multi ID	Mode	Control	
Value	0x02	0x73	0x01	0x04	Variable	Variable	Variable	Variable	0x03

*Group/Multi ID Range(Program) : Group ID : 0x01 / Multi ID : 0x01 Fixed
 *Mode : Read(Get) – 0x00(0) , Write(Set) – 0x02(2)
 *Control : Deselect DHCP Disable – 0x00(0), Select DHCP Enable – 0x01(1)

- **Receive From LCD**

	STX	CMD	Ex CMD	Length	Data				Check Sum	ETX
					Group ID	Multi ID	Mode	Control		
Value	0x02	0x64	0x01	0x04	Variable	Variable	Variable	Variable	Variable	0x03

*Group ID/Multi ID range(Program) : Group ID : 0x01 / Multi ID : 0x01 Fixed
 *Mode : Read(Get)Response – 0x00(0), Write(Set)Response – 0x02(2)
 *Control : Deselect DHCP Disable – 0x00(0), Select DHCP Enable – 0x01(1)
 *Check Sum: Execute "Not" operation after adding all the values in "STX~Data" area.

6.5. LCD Network IP

- This is the command for configuring IP Address (DHCP Disable), Subnet Mask, Default Gateway, DNS Primary, and DNS Secondary to allocate the Network IP directly for LCD.

- **Send To LCD**

	STX	CMD	Ex CMD	Length	Data								ETX	
					Group ID	Multi ID	Mode	Control						
Value	0x02	0x74	0x01	0x17	Variable	Variable	Variable	Variable	Variable	Variable	Variable	Variable	Variable	0x03

Value	IP Address (4Byte)				Subnet Mask (4Byte)				Default Gateway (4Byte)				DNS Primary (4Byte)				DNS Secondary (4Byte)			
	Variable	Variable	Variable	Variable	Variable	Variable	Variable	Variable	Variable	Variable	Variable	Variable	Variable	Variable	Variable	Variable	Variable	Variable	Variable	Variable

*Group ID/Multi ID range(Program) : Group ID : 0x01 / Multi ID : 0x01 Fixed

*Mode : Write(Set) – 0x02(2)

*Control Value: The ranges of each 1Byte of IP Address, Subnet Mask, Default Gateway, DNS Primary, or DNS Secondary are from 0(0x00) to 255(0xFF)

- **Receive From LCD**

	STX	CMD	Ex CMD	Length	Data				Check Sum	ETX
					Group ID	Multi ID	Mode	Control		
Value	0x02	0x74	0x01	0x17	Variable	Variable	Variable	Variable	Variable	0x03

Value	IP Address (4Byte)				Subnet Mask (4Byte)				Default Gateway (4Byte)				DNS Primary (4Byte)				DNS Secondary (4Byte)			
	Variable	Variable	Variable	Variable	Variable	Variable	Variable	Variable	Variable	Variable	Variable	Variable	Variable	Variable	Variable	Variable	Variable	Variable	Variable	Variable
	Variable	Variable	Variable	Variable	Variable	Variable	Variable	Variable	Variable	Variable	Variable	Variable	Variable	Variable	Variable	Variable	Variable	Variable	Variable	Variable

*Group ID/Multi ID range(Program) : Group ID : 0x01 / Multi ID : 0x01 Fixed

*Mode : Write(Set)Response – 0x02(2)

*Control : The ranges of each 1Byte of IP Address, Subnet Mask, Default Gateway, DNS Primary, or DNS Secondary are from 0(0x00) to 255(0xFF)

*Check Sum: Execute "Not" operation after adding all the values in "STX~Data" area.

6.6. Get LCD Network IP

- This is the command for checking the configuration for LCD Network IP such as DHCP settings, IP Address, Subnet Mask, Default Gateway, DNS Primary, and DNS Secondary.

- CMD : 0x75

- **Send To LCD**

	STX	CMD	Ex CMD	Length	Data			ETX
					Group ID	Multi ID	Mode	
Value	0x02	0x75	0x01	0x03	Variable	Variable	Variable	0x03

*Group/Multi ID Range(Program) : Group ID : 0x01 / Multi ID : 0x01 Fixed

*Mode : Read(Get) – 0x00(0)

- **Receive From LCD**

	STX	CMD	Ex CMD	Length	Data				Check Sum	ETX
					Group ID	Multi ID	Mode	Control		
Value	0x02	0x75	0x01	0x18	Variable	Variable	Variable	Variable	Variable	0x03

Value	DHCP ON,OFF (1Byte)	IP Address (4Byte)				Subnet Mask (4Byte)				Default Gateway (4Byte)				DNS Primary (4Byte)				DNS Secondary (4Byte)			
	Variable	Variable	Variable	Variable	Variable	Variable	Variable	Variable	Variable	Variable	Variable	Variable	Variable	Variable	Variable	Variable	Variable	Variable	Variable	Variable	Variable
	Variable	Variable	Variable	Variable	Variable	Variable	Variable	Variable	Variable	Variable	Variable	Variable	Variable	Variable	Variable	Variable	Variable	Variable	Variable	Variable	Variable

*Group ID/Multi ID range(Program) : Group ID : 0x01 / Multi ID : 0x01 Fixed

*Mode : Read(Get) – 0x00(0)

*Control: If DHCP configuration is deselected, it is 0(0x00). If it is selected, it is 1(0x01). The length of IP Address, Subnet Mask, Default Gateway, DNS Primary, and DNS Secondary is 4Bytes, respectively.

*Check Sum: Execute "Not" operation after adding all the values in "STX~Data" area.

6.7. Get MAC Address

- This is the command for checking MAC Address.

- CMD : 0x76

- **Send To LCD**

	STX	CMD	Ex CMD	Length	Data			ETX
					Group ID	Multi ID	Mode	
Value	0x02	0x76	0x01	0x03	Variable	Variable	Variable	0x03

*Group/Multi ID Range(Program) : Group ID : 0x01 / Multi ID : 0x01 Fixed

*Mode : Read(Get) – 0x00(0)

- **Receive From LCD**

	STX	CMD	Ex CMD	Length	Data				Check Sum	ETX
					Group ID	Multi ID	Mode	Control		
Value	0x02	0x76	0x01	0x09	Variable	Variable	Variable	Variable	Variable	0x03

Value	Mac Address (1Byte)	Mac Address (1Byte)	Mac Address (1Byte)	Mac Address (1Byte)	Mac Address (1Byte)	Mac Address (1Byte)
		Variable	Variable	Variable	Variable	Variable

*Group ID/Multi ID range(Program) : Group ID : 0x01 / Multi ID : 0x01 Fixed

*Mode : Read(Get) – 0x00(0)

*Control Value: The range of each value is from 0(0x00) to 255(0xFF).

*Check Sum: Execute "Not" operation after adding all the values in "STX~Data" area.

6.8. Baud Rate

- This is the command for configuring the Baud Rate for LCD communication.

- It is available only during Power On (Operative) status.

- CMD : 0x78

- **Send To LCD**

	STX	CMD	Ex CMD	Length	Data				ETX
					Group ID	Multi ID	Mode	Control	
Value	0x02	0x78	0x01	0x04	Variable	Variable	Variable	Variable	0x03

*Group ID/Multi ID range(Program) : Group ID : 0x01 / Multi ID : 0x01 Fixed

*Mode : Write(Set) – 0x02(2)

*Control : 9600 – 1(0x01), 14400 – 2(0x02), 19200 – 3(0x03), 38400 – 4(0x04), 57600 – 5(0x05), 115200 – 6(0x06)

- **Receive From LCD**

	STX	CMD	Ex CMD	Length	Data				Check Sum	ETX
					Group ID	Multi ID	Mode	Control		
Value	0x02	0x78	0x01	0x04	Variable	Variable	Variable	Variable	Variable	0x03

*Group ID/Multi ID range(Program) : Group ID : 0x01 / Multi ID : 0x01 Fixed

*Mode : Write(Set)Response – 0x02(2)

*Control : 9600 – 1(0x01), 14400 – 2(0x02), 19200 – 3(0x03), 38400 – 4(0x04), 57600 – 5(0x05), 115200 – 6(0x06)

*Check Sum: Execute "Not" operation after adding all the values in "STX~Data" area.

6.9. Get Baud Rate Data

- This is the command for checking the configuration of the Baud Rate for LCD communication.

- It is available only during Power On (Operative) status.

- CMD : 0x79

- **Send To LCD**

	STX	CMD	Ex CMD	Length	Data			ETX
					Group ID	Multi ID	Mode	
Value	0x02	0x79	0x01	0x03	Variable	Variable	Variable	0x03

*Group/Multi ID Range(Program) : Group ID : 0x01 / Multi ID : 0x01 Fixed
 *Mode : Read(Get) – 0x00(0)

- **Receive From LCD**

	STX	CMD	Ex CMD	Length	Data				Check Sum	ETX
					Group ID	Multi ID	Mode	Control		
Value	0x02	0x79	0x01	0x04	Variable	Variable	Variable	Variable	Variable	0x03

*Group ID/Multi ID range(Program) : Group ID : 0x01 / Multi ID : 0x01 Fixed
 *Mode : Read(Get) – 0x00(0)
 *Control : 9600 – 1(0x01), 14400 – 2(0x02), 19200 – 3(0x03), 38400 – 4(0x04), 57600 – 5(0x05), 115200 – 6(0x06)
 *Check Sum: Execute "Not" operation after adding all the values in "STX~Data" area.

6.10. OSD Turn Off

- This is the command for configuring the duration time for OSD Menu.
- It is available only during Power On (Operative) status.
- CMD : 0x7D

- **Send To LCD**

	STX	CMD	Ex CMD	Length	Data				ETX
					Group ID	Multi ID	Mode	Control	
Value	0x02	0x7D	0x01	0x04	Variable	Variable	Variable	Variable	0x03

*Group/Multi ID Range(Program) : Group ID : 0x01 / Multi ID : 0x01 Fixed
 *Mode : Write(Set) – 0x02(2)
 *Control: The value for Turn OFF is 0(0x00), 10 seconds is 1(0x01), 20 seconds is 2(0x02), and 30 seconds is 3(0x03).

- **Receive From LCD**

	STX	CMD	Ex CMD	Length	Data				Check Sum	ETX
					Group ID	Multi ID	Mode	Control		
Value	0x02	0x7D	0x01	0x04	Variable	Variable	Variable	Variable	Variable	0x03

*Group/Multi ID Range(Program) : Group ID : 0x01 / Multi ID : 0x01 Fixed
 *Mode : Write(Set)Response – 0x02(2)
 *Control: The value for Turn OFF is 0(0x00), 10 seconds is 1(0x01), 20 seconds is 2(0x02), and 30 seconds is 3(0x03).
 *Check Sum: Execute "Not" operation after adding all the values in "STX~Data" area.

6.11. OSD Info Display Time

- This is the command for selecting Info OSD display on the screen and configuring the duration.
- It is available only during Power On (Operative) status.
- CMD : 0x80

- **Send To LCD**

	STX	CMD	Ex CMD	Length	Data				ETX
					Group ID	Multi ID	Mode	Control	
Value	0x02	0x80	0x01	0x04	Variable	Variable	Variable	Variable	0x03

*Group/Multi ID Range(Program) : Group ID : 0x01 / Multi ID : 0x01 Fixed
 *Mode : Read(Get) – 0x00(0), Write(Set) – 0x02(2)
 *Control Value: The value for OFF is 0(0x00) and the duration can be selected between 3(0x03) and 10(0x0A).

- **Receive From LCD**

	STX	CMD	Ex CMD	Length	Data				Check Sum	ETX
					Group ID	Multi ID	Mode	Control		
Value	0x02	0x80	0x01	0x04	Variable	Variable	Variable	Variable	Variable	0x03

*Group/Multi ID Range(Program) : Group ID : 0x01 / Multi ID : 0x01 Fixed
 *Mode : Read(Get)Response – 0x00(0), Write(Set)Response – 0x02(2)
 *Control Value: The value for OFF is 0(0x00) and the duration can be selected between 3(0x03) and 10(0x0A).
 *Check Sum: Execute "Not" operation after adding all the values in "STX~Data" area.

6.12. Get OSD Control Data

- This is the command for checking the OSD related configuration such as OSD Turn Off Time, or OSD Info Display duration.
- It is available only during Power On (Operative) status.
- CMD : 0x82

- **Send To LCD**

	STX	CMD	Ex CMD	Length	Data			ETX
					Group ID	Multi ID	Mode	
Value	0x02	0x82	0x01	0x03	Variable	Variable	Variable	0x03

*Group ID/Multi ID range(Program) : Group ID : 0x01 / Multi ID : 0x01 Fixed
 *Mode : Read(Get) – 0x00(0)

- **Receive From LCD**

	STX	CMD	Ex CMD	Length	Data				Check Sum	ETX
					Group ID	Multi ID	Mode	Control		
Value	0x02	0x82	0x01	0x05	Variable	Variable	Variable	Variable	Variable	0x03

	OSD Turn Off Time (1Byte)	OSD Info Display Time (1Byte)
Value	Variable	Variable

*Group ID/Multi ID range(Program) : Group ID : 0x01 / Multi ID : 0x01 Fixed
 *Mode : Read(Get)Response – 0x00(0)
 *Control Value : The value for Turn OFF is 0(0x00), 10 seconds is 1(0x01), 20 seconds is 2(0x02), and 30 seconds is 3(0x03).
 The duration rages for OSD Info Display Time can be selected between 3(0x03) and 10(0x0A) and OFF is 0(0x00).
 *Check Sum: Execute "Not" operation after adding all the values in "STX~Data" area.

7. SETUP B Command

7.1. Power On Source

- This is the command for selecting and configuring the input source that should be detected with the first priority at the time of Power On.
- It is available only during Power On (Operative) status.
- CMD : 0x63

- **Send To LCD**

	STX	CMD	Ex CMD	Length	Data				ETX
					Group ID	Multi ID	Mode	Control	
Value	0x02	0x63	0x01	0x04	Variable	Variable	Variable	Variable	0x03

*Group/Multi ID Range(Program) : Group ID : 0x01 / Multi ID : 0x01 Fixed
 *Mode : Write(Set) – 0x02(2)
 *Control : Input Source configuration
 0x10 is for the last input source at the time of the last Power Off. 0x11(HDMI1A), 0x12(HDMI1B), 0x13(HDMI1C), 14(HDMI1D), 0x15(HDMI2A), 0x16(HDMI2B), 0x17(HDMI2C), 0x18(HDMI2D), 0x31(UHD 1), 0x32(UHD 2).

- **Receive From LCD**

	STX	CMD	Ex CMD	Length	Data				Check Sum	ETX
					Group ID	Multi ID	Mode	Control		
Value	0x02	0x63	0x01	0x04	Variable	Variable	Variable	Variable	Variable	0x03

*Group/Multi ID Range(Program) : Group ID : 0x01 / Multi ID : 0x01 Fixed
 *Mode : Write(Set)Response – 0x02(2)
 *Control : Input Source configuration
 0x10 is for the last input source at the time of the last Power Off. 0x11(HDMI1A), 0x12(HDMI1B), 0x13(HDMI1C), 14(HDMI1D),
 0x15(HDMI2A), 0x16(HDMI2B), 0x17(HDMI2C), 0x18(HDMI2D), 0x31(UHD 1), 0x32(UHD 2).
 *Check Sum: Execute "Not" operation after adding all the values in "STX~Data" area.

7.2. Get Power On Source Data

- This is the command for checking the configuration of the input source that should be detected with the first priority at the time of Power On.
- It is available only during Power On (Operative) status.
- CMD : 0x66
- **Send To LCD**

	STX	CMD	Ex CMD	Length	Data			ETX
					Group ID	Multi ID	Mode	
Value	0x02	0x66	0x01	0x03	Variable	Variable	Variable	0x03

*Group/Multi ID Range(Program) : Group ID : 0x01 / Multi ID : 0x01 Fixed
 *Mode : Read(Get) – 0x00(0)

- **Receive From LCD**

	STX	CMD	Ex CMD	Length	Data				Check Sum	ETX
					Group ID	Multi ID	Mode	Control		
Value	0x02	0x66	0x01	0x04	Variable	Variable	Variable	Variable	Variable	0x03

*Group/Multi ID Range(Program) : Group ID : 0x01 / Multi ID : 0x01 Fixed
 *Mode : Read(Get)Response – 0x00(0)
 *Control : Input Source configuration
 0x10 is for the last input source at the time of the last Power Off. 0x11(HDMI1A), 0x12(HDMI1B), 0x13(HDMI1C), 0x14(HDMI1D),
 0x15(HDMI2A), 0x16(HDMI2B), 0x17(HDMI2C), 0x18(HDMI2D), 0x31(UHD 1), 0x32(UHD 2).
 *Check Sum: Execute "Not" operation after adding all the values in "STX~Data" area.

7.3. KEY LOCK

- It prevents the unexpected change for panel or set configuration.
- CMD : 0xB0
- **Send To LCD**

	STX	CMD	Ex CMD	Length	Data				ETX
					Group ID	Multi ID	Mode	Control	
Value	0x02	0xB0	0x01	0x04	Variable	Variable	Variable	Variable	0x03

*Group ID/Multi ID range(Program) : Group ID : 0x01 / Multi ID : 0x01 Fixed
 *Mode : Read(Get) – 0x00(0) , Write(Set) – 0x02(2)
 *Control : Panel Key Lock Off – 0x00(0) , Panel Key Lock On – 0x01(1)

- **Receive From LCD**

	STX	CMD	Ex CMD	Length	Data				Check Sum	ETX
					Group ID	Multi ID	Mode	Control		
Value	0x02	0xB0	0x01	0x04	Variable	Variable	Variable	Variable	Variable	0x03

*Group ID/Multi ID range(Program) : Group ID : 0x01 / Multi ID : 0x01 Fixed
 *Mode : Read(Get)Response – 0x00(0) , Write(Set)Response – 0x02(2)
 *Control : Panel Key Lock Off – 0x00(0) , Panel Key Lock On – 0x01(1)
 *Check Sum: Execute "Not" operation after adding all the values in "STX~Data" area.

8. Factory Control Command

8.1. Dimming Control

- This is the command for controlling the brightness of LCD back light.
- It is available only during Power On (Operative) status.
- CMD : 0x1D
- **Send To LCD**

	STX	CMD	Ex CMD	Length	Data				ETX
					Group ID	Multi ID	Mode	Control	
Value	0x02	0x1D	0x01	0x04	Variable	Variable	Variable	Variable	0x03

*Group/Multi ID Range(Program) : Group ID : 0x01 / Multi ID : 0x01 Fixed
 *Mode : Read(Get) – 0x00(0) , Write(Set) – 0x02(2)
 *Control Value: The range of Control value is from 0x00(0) to 0xFF(255).

- **Receive From LCD**

	STX	CMD	Ex CMD	Length	Data				Check Sum	ETX
					Group ID	Multi ID	Mode	Control		
Value	0x02	0x1D	0x01	0x04	Variable	Variable	Variable	Variable	Variable	0x03

*Group/Multi ID Range(Program) : Group ID : 0x01 / Multi ID : 0x01 Fixed
 *Mode : Read(Get)Response – 0x00(0) , Write(Set)Response – 0x02(2)
 *Control Value: The range of Control value is from 0x00(0) to 0xFF (255).
 *Check Sum: Execute "Not" operation after adding all the values in "STX~Data" area.

8.2. White Balance Control

- This is the command for adjusting the values for Gain RGB or Offset RGB of White Balance.
- Since the adjusted values cannot be applied while Stand-by status or without input signal, LCD must be in operating condition with input signal.
- CMD : 0x27(Gain Red), 0x28(Gain Green), 0x29(Gain Blue), 0x2A(Offset Red), 0x2B(Offset Green), 0x2C(Offset Blue)
- **Send To LCD**

	STX	CMD	Ex CMD	Length	Data				ETX
					Group ID	Multi ID	Mode	Control	
Value	0x02	Variable	0x01	0x04	Variable	Variable	Variable	Variable	0x03

*Group/Multi ID Range(Program) : Group ID : 0x01 / Multi ID : 0x01 Fixed
 *Mode : Write(Set) – 0x02
 *Control: The controllable range of Gain RGB and Offset RGB is from 0(0x00) to 200(0xC8), respectively.

- **Receive From LCD**

	STX	CMD	Ex CMD	Length	Data				Check Sum	ETX
					Group ID	Multi ID	Mode	Control		
Value	0x02	Variable	0x01	0x04	Variable	Variable	Variable	Variable	Variable	0x03

*Group/Multi ID Range(Program) : Group ID : 0x01 / Multi ID : 0x01 Fixed
 *Mode : Write(Set)Response – 0x02(2)
 *Control: The controllable range of Gain RGB and Offset RGB is from 0(0x00) to 200(0xC8), respectively.
 *Check Sum: Execute "Not" operation after adding all the values in "STX~Data" area.

09. Before calling for service

- Before calling for any repair, check the following and then refer to a near A/S center.

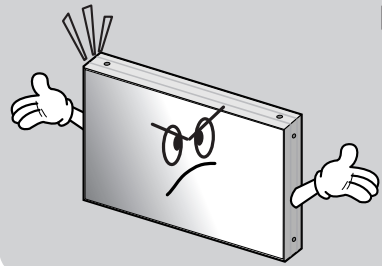

► "Tick" sound from the main body.

- If there is no problem with the screen or sound, the "tick" sound is likely to result from the cabinet lightly shrinking with the change of room temperature. The sound does not affect product's performance.

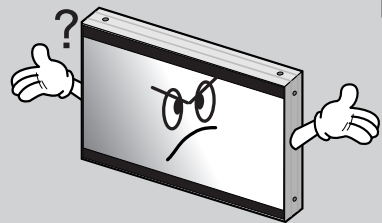

► No image at upper and lower part of the screen.

- As for a screen which is over 16:9 in width (such as cinema-sized one), no image may be displayed at upper and bottom part of the screen.

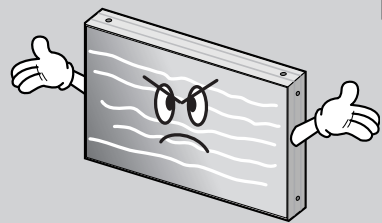

► Speckles or white lines on the screen

- Check whether the problem is caused by vehicle, streetcar, high-voltage cable or neon sign, which emitting interference wave or electromagnetic induction. Avoid any interfering object.

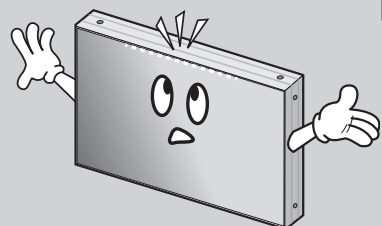

► Light leakage can be found at the edge areas around the screen.

- If the light leakage is not detected at 1m from the screen, the panel is considered as no defect.(SAMSUNG LCD applies the same inspection standard)
- To minimize the light leakage, the MLCD sets should be installed with high accuracy in horizontal and vertical position.

10. Applicable signals

Resolution	Pixe Clock [Mhz]	Horizontal [Pixels]					Vertical [Lines]					Polarity (H/V)	Standard Type
		Total	Addr. Width	Front Porch	Sync. Width	Back Porch	Total	Addr. Width	Front Porch	Sync. Width	Back Porch		
640*480*60	25.175	800	640	8	96	40	525	480	2	2	25	-/-	DMT
800*600*50	30.750	992	800	24	72	96	621	600	3	4	14	+/+	CVT
800*600*60	40.000	1054	800	40	128	88	628	600	1	4	23	+/+	DMT
1024*576*50	34.750	1184	1024	48	32	80	590	576	3	5	6	+/-	VESA Blanked
1024*576*60	46.500	1296	1024	40	96	136	599	576	3	5	15	+/+	VESA
1024*768*60	65.000	1344	1024	24	136	160	806	768	3	6	29	-/-	DMT
1280*768*60	79.500	1664	1280	64	128	192	798	768	3	7	20	-/+	CVT
1280*960*60	108.000	1800	1280	96	112	312	1000	960	1	3	36	+/+	CVT
1280*1024*50	88.500	1680	1280	72	128	200	1057	1024	3	7	23	+/+	CVT
1280*1024*60	108.000	1688	1280	48	112	248	1066	1024	1	3	38	+/+	DMT
1360*768*50	69.000	1744	1360	56	136	192	793	768	3	5	17	-/+	CVT
1360*768*60	85.500	1792	1360	64	112	256	795	768	3	6	18	+/+	DMT
1400*1050*60	121.750	1864	1400	88	144	232	1089	1050	3	4	32	-/+	CVT
1600*900*50	96.500	2080	1600	80	160	240	929	900	3	5	21	-/+	CVT
1600*900*60	118.250	2112	1600	88	168	256	934	900	3	5	26	-/+	CVT
1600*1200*50	131.500	2128	1600	96	168	264	1238	1200	3	4	31	+/+	CVT
1600*1200*60	162.000	2160	1600	64	192	304	1250	1200	1	3	46	+/+	DMT
480p	27.000	858	720	14	62	62	525	480	9	6	30	+/+	DTV
576p	27.000	864	720	12	64	68	625	576	5	5	39	+/+	DTV
720p50	74.250	1980	1280	400	80	220	750	720	5	5	20	+/+	DTV
720p60	74.250	1650	1280	70	80	220	750	720	5	5	20	+/+	DTV
1080i50	74.250	2640	1920	484	88	148	1125	1080	5	10	30	+/+	DTV
1080i60	74.250	2200	1920	44	88	148	1120	1080	5	10	25	+/+	DTV
1080p50	148.500	2640	1920	484	88	148	1125	1080	4	5	36	-/-	DTV
1080p60	148.500	2200	1920	44	88	148	1125	1080	4	5	36	-/-	DTV

11. Specification

▶ Product

Model Name	OLS-8410NL	OLS-8410T6LG	OLS-8420NL
Back Light Type	LED		
Power Supply	AC100V ~ 240V (50/60Hz)		
Power Consumption	Max	470W	
	Typical	440W	
	Stand-By	0.45W	
Luminance of White	350 cd / m ² (Max.)	5000 cd / m ² (Max.)	
Contrast ratio (Dark Room)	1,600:1 (Typical)		
Active Display Area (H X V)	1860.48 X 1046.52mm		
Aspect Ratio	16 : 9		
Number of pixels	3840 (H) X 2160 (V)		
Pixel Pitch	0.4845 X 0.4845 mm		
Display Colors	1.06Billion Colors		
Viewing Angle	H : 178°, V : 178°		
Response Time (G to G)	8msec (Typ.)		
Environmental condition	Temperature	5°C ~ 35°C	
	Humidity	35% ~ 75%	
Input Signal	HDMI (HDCP Available)	VGA, SVGA, XGA, SXGA, UXGA, WXGA, 480p,576p,720p(50/60),1080i(50/60),1080p(50/60)	
	Frequency	H : 31.5 ~ 75kHz, V : 50 , 60 Hz	
Input port	HDMI x 8, RS-232C x 1, LAN x1, A/S x 1, IR x 1		
Lamp Life Time	Typ. 50.000Hrs (Ta : 25 ± 2°C)		
Dimension (W X H X D)	1917x 1103 x 95mm	1977.2 x 1163.2 x 104.3mm	1917x 1103 x 95mm
Weights	72Kg(±0.5Kg)	120Kg(±0.5Kg)	72Kg(±0.5Kg)
Installation	Landscape only		Landscape/Portrait

※Product design and specification can be changed for quality improvement without prior notice.

▶ Touch

Item	Description
Touch Technology	PulseIRTM Technology
Touch Method	Finger, gloved hand or Any other pointer, Stylus minimum Ø 8mm
Touch Activation Force	No pressure required
Position Accuracy	Typical centroid accuracy 2mm
Resolution	16,383(W) X 16,383(D)
Response Time	5ms to 25ms depending on conguration Typical response time : 15ms
Glass	Transmission : Better than 85% with glass Thickness : 5mm Tempered Glass(Option AG/AR)
Optics Quantity	326 (H) X 183(V) pairs
Touch Intensity	Over 60,000,000 single point touch
Support OS	Windows XP, Vista, Windows 7, Windows 8 32bit and 64bit / Windows CE Linux / Mac OS * No device driver required
True Multi-Touch	Detects up to 6 points.

※Product design and specification can be changed for quality improvement without prior notice.

12. Dimension

▶ OLS-8410NL/OLS-8420NL

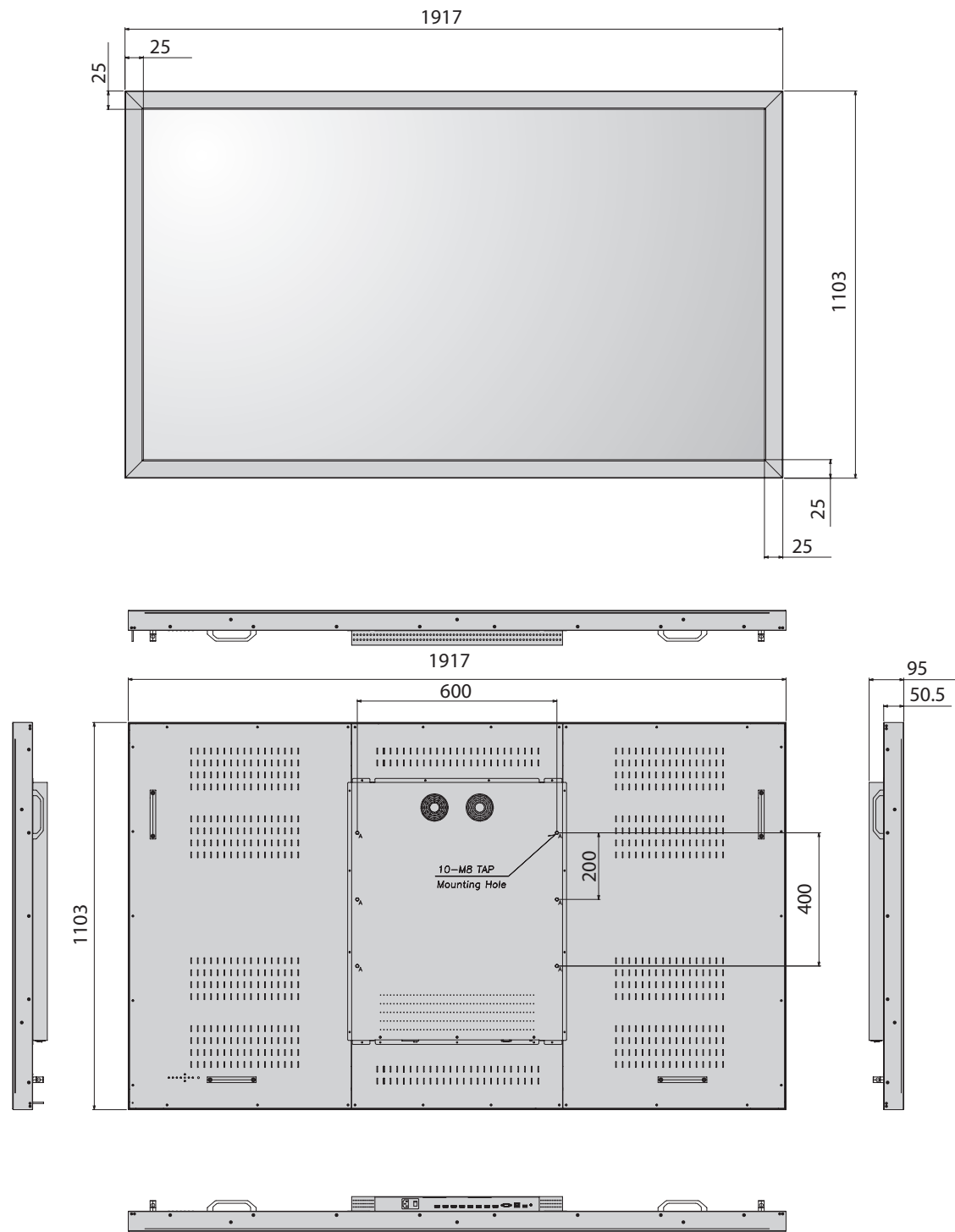

▶ OLS-8410T6L

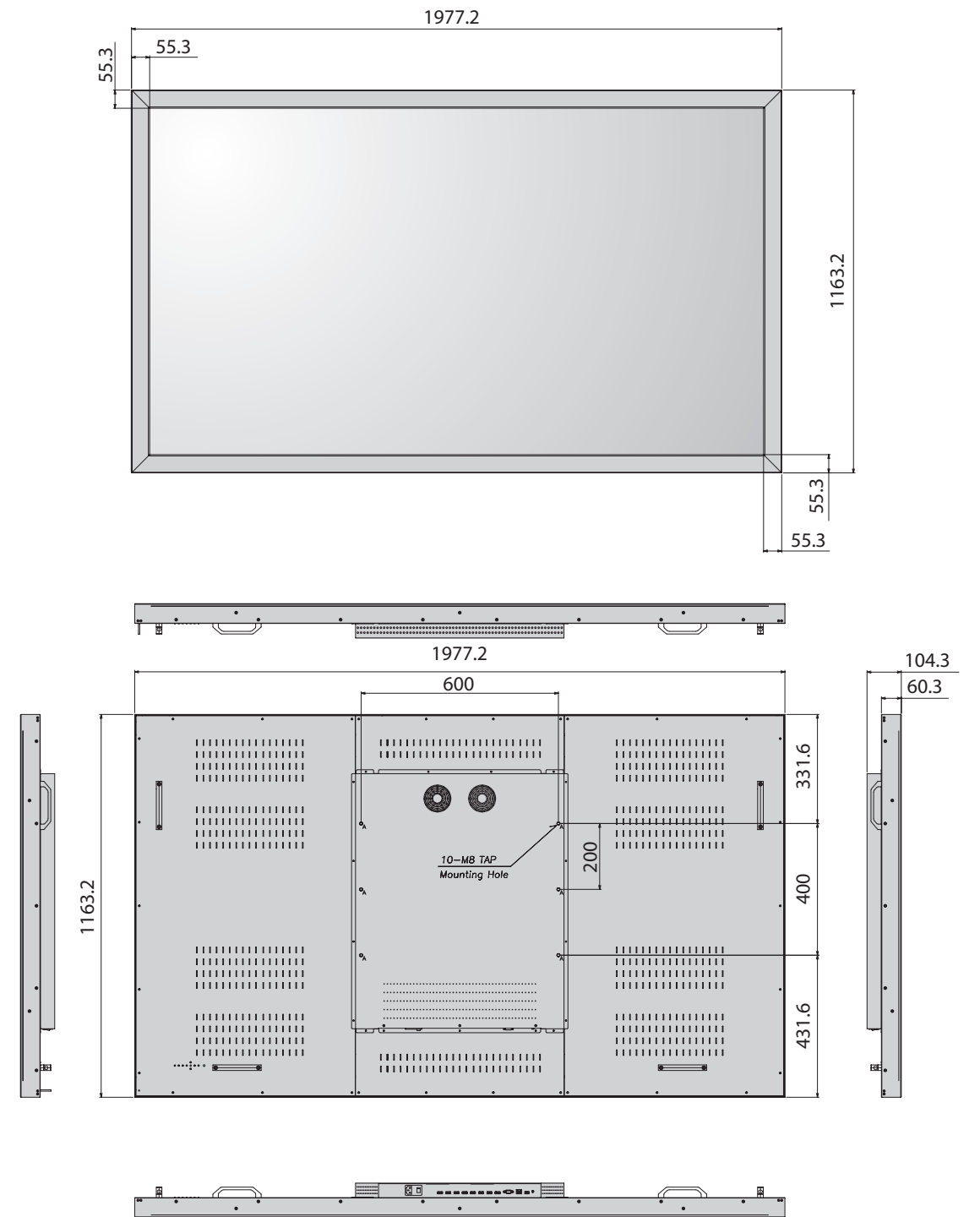

Memo