

MAIN FRAME

ORION CO.,LTD.
www.oriondisplay.net

Address: 257-6, Gongdan-dong, Gumi-si, Gyeongsangbuk-do, Korea
Tel : +82-2-6678-8533, Fax: +82-2-6678-8599

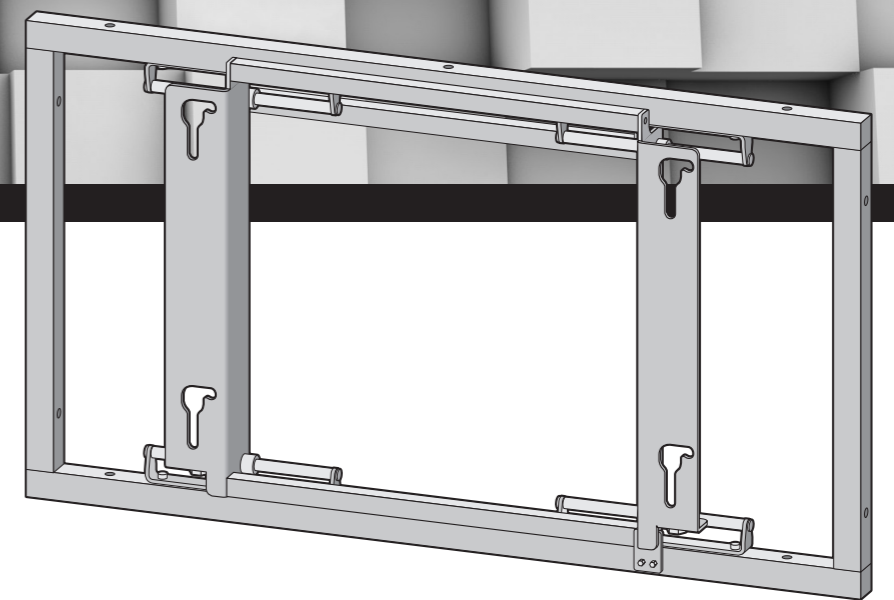

USER MANUAL STAND UNIT | WALL UNIT

Thank you for purchasing our MAIN FRAME.
Please read through this user's manual for safety before installing this product.
This product is manufactured for Multi LCD model only.

Contents

ACCESSORY	2
OPTIONAL	2
STAND UNIT	3
1. Safety Precaution	4
2. Installing the stand (3*3)	6
3. Installing the MLCD	16
4. Adjust the MLCD gap with the Adjuster.	19
5. Setting MLCD ID configuration and Connection (3X3).....	20
WALL UNIT	21
1. Safety Precaution	22
2. Checking the location for installation.	24
3. Fixing Anchor and Bolt	25
4. Installing the Wall Bracket (3 X 3)	26
5. Installing the MLCD	37
6. Adjust the MLCD gap with the Adjuster.	41
SPECIFICATION	42

ACCESSORY

* MAIN FRAME Accessories

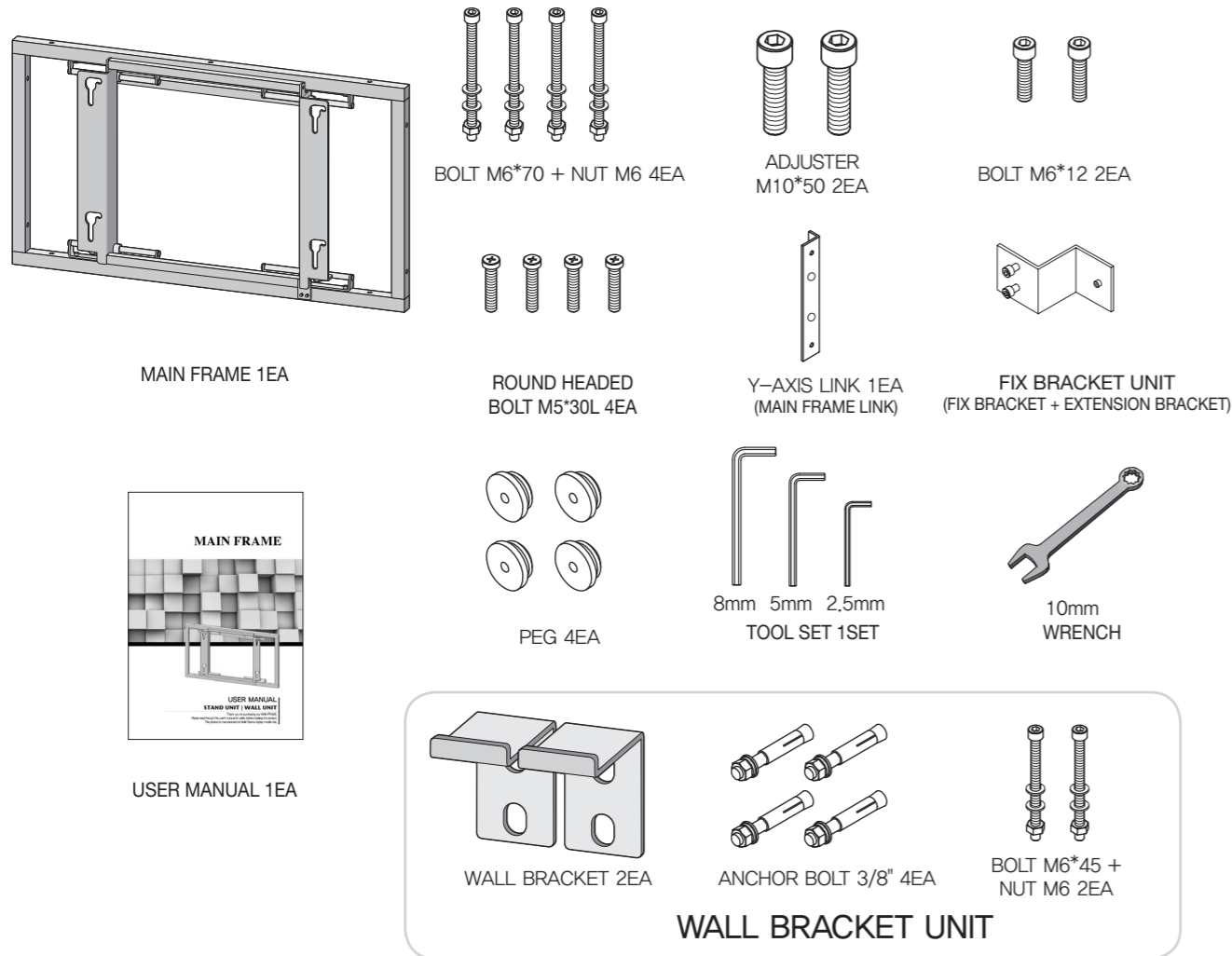

OPTIONAL

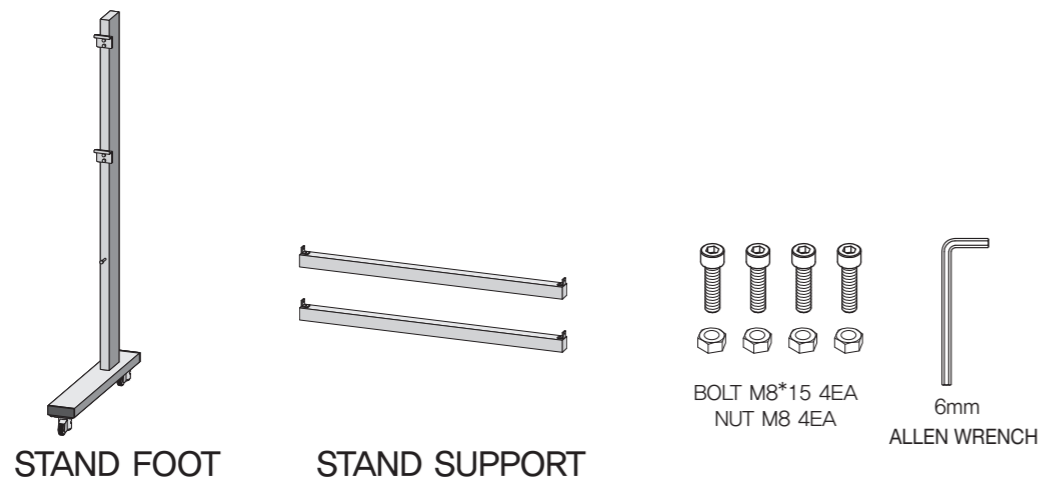

STAND UNIT

* This manual describes the installation case for 3X3 sets.
* There are 4 different types of stand. Please select a stand type as you need.

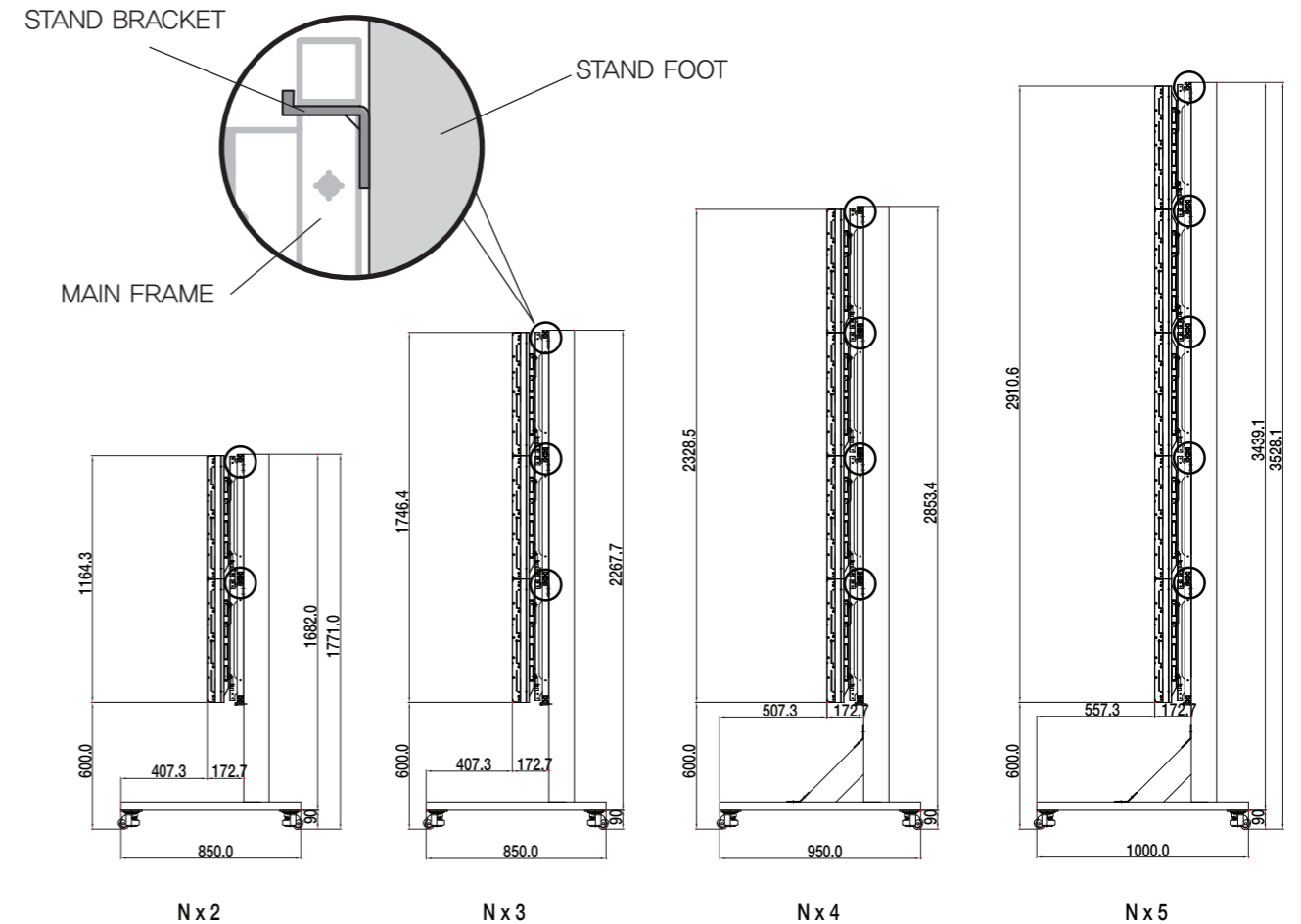

* In case of NX3, NX4, or NX5 set formations, there is no stand bracket for the top line of main frames. However, it is designed to firmly fasten the main frames of the top line to the main frames of the next line.

	SCREEN SIZE (MM)	
	OLM-4610	OLM-4650
1 X 1	1025.7 x 579.9	1025.7 x 579.9
2 X 2	2051.4 x 1159.8	2051.4 x 1159.8
3 X 3	3077.1 x 1739.7	3077.1 x 1739.7
4 X 4	4102.8 x 2319.6	4102.8 x 2319.6
5 X 5	5128.5 x 2899.5	5128.5 x 2899.5

1. Safety Precaution

- * Please read and understand this manual fully before installation.
- * Please hand over this manual to customers after installation and ask to read and keep this manual for future use.
- ※ Please keep all the cautions and warnings for proper use of the product and prevent possible accident or hazard.
- ※ You can find “CAUTION” and “WARNING” signs in this manual. Each sign has following meaning.

! WARNING If the user does not comply with this instruction, serious injuries or death can be caused.

! CAUTION If the user does not comply with this instruction, minor injuries or product damage can be caused.

! WARNING

Installation must be done by the skilled persons designated by sales agent or dealership.
 Installation work can be very dangerous for inexperienced person.
 It may cause serious injury or even death.

Do not install at unstable locations that cannot withstand product weight.
 In case of weak floor or ground, product may fall and cause injuries.

If you need to move or replace the product, please contact with skilled persons designated by sales agent or dealership
 If users move or install the product without proper skill and experience, it may cause safety problem.

Do not hang on the product and avoid severe impact to the product.
 Product may fall and cause injuries.

! CAUTION

Please install as described in this manual.
 Improper installation may cause serious injury or product damage.

Installation of this product needs 3 or more people.
 3 or more people need to work together to avoid personal injury or product damage.

Use enclosed accessories.
 Improper accessories may not withstand the weight of the product. It may cause safety problems.

Install on the even ground or floor.
 Product installed on uneven places such as inclined places or stairways may fall and cause personal injury or product damage.

Do not use heaters or humidifiers at the place of installation.
 Heat or vapor may cause fire, electric shock or malfunction.

Do not install the product near to sprinkler, fire detector, high-voltage cable, power source, or places of vibration or impact.

Make sure to disconnect before installation.
 If you install the product while the power cord is still connected, it may cause electric shock or fire.

Use working gloves when you install.
 Wear working gloves to avoid any injury.

2. Installing the stand (3*3)

1 Connect the Foot Stand and Stand Support together.

- When assembling, put the Foot Stand down to prevent it from falling.
- Attach the Stand Support to the upper and lower parts of the Foot Stand
- After assembling, check if it would stand on its own.

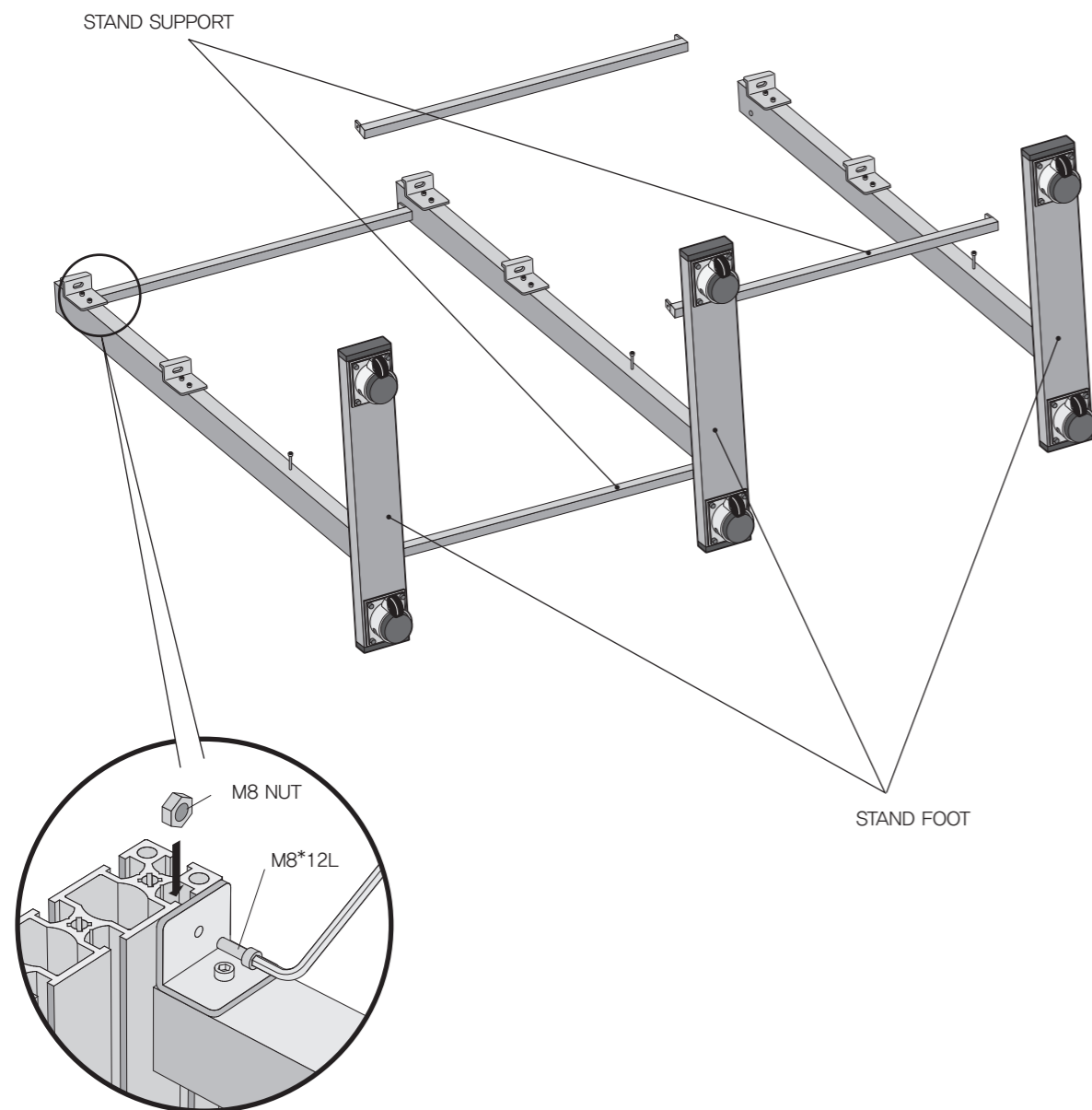

After inserting M8 NUT, apply the M8*12 bolt with the enclosed 6mm allen wrench.

2 Hook the main Frame to the lower part of the Stand.

- Assemble the Main Frame from the lower to the upper part.
- Insert the M6*70 bolt to the Main Frame and Stand Hook.
- If the M6*70 bolt was not inserted, the Main Frame would fall or be damaged.

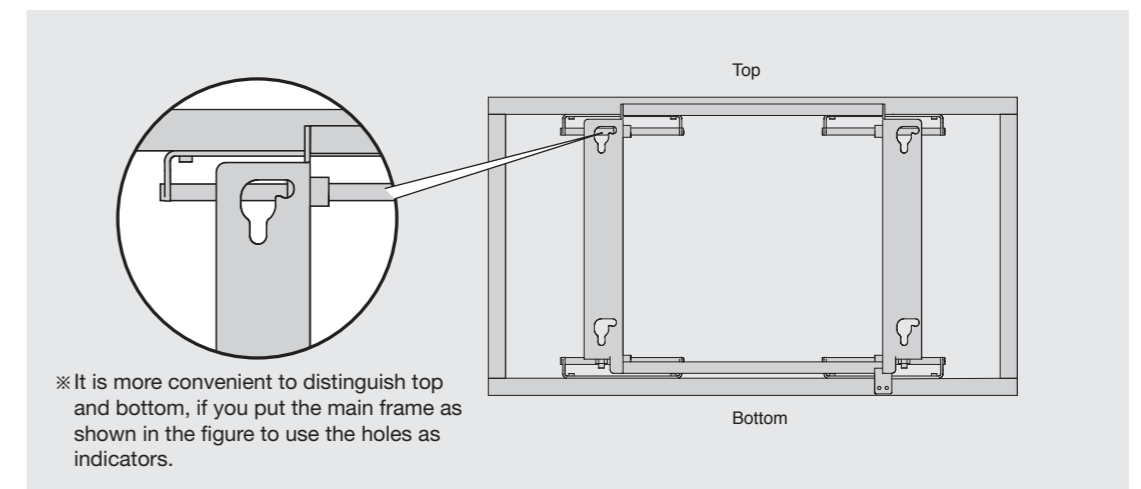
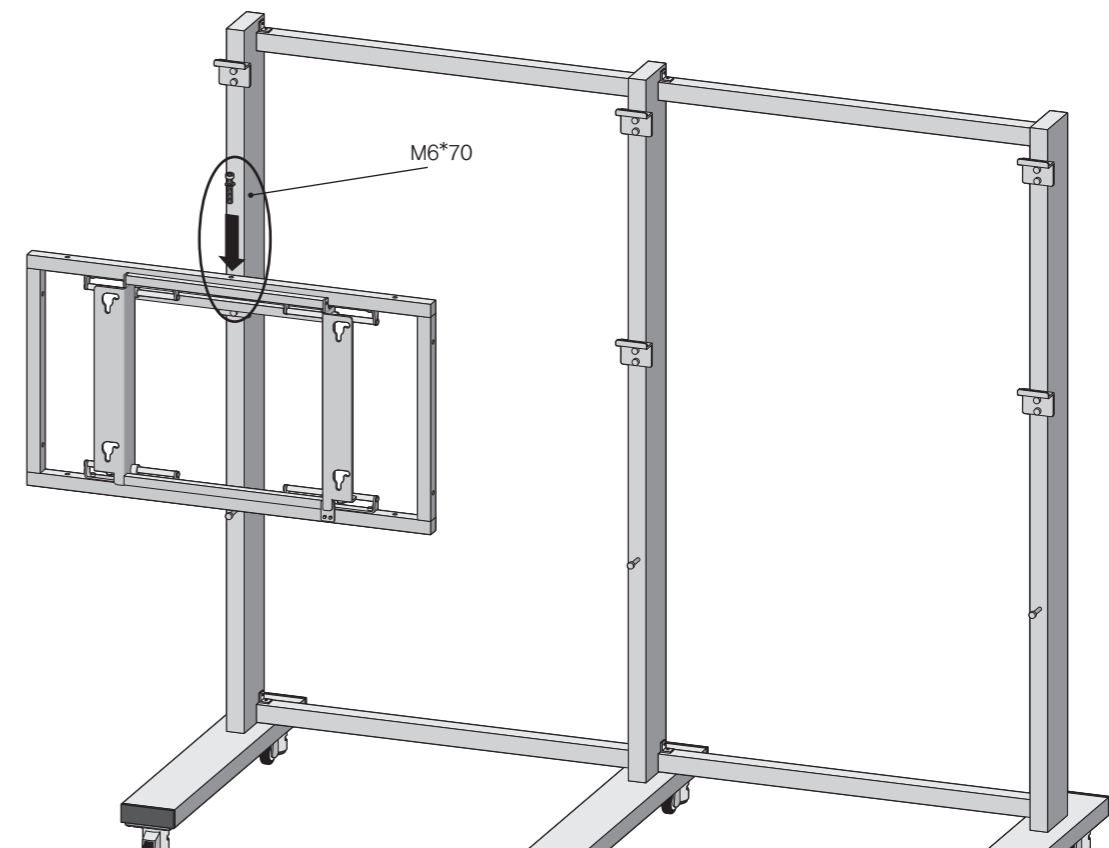

3 Hook the 2nd main Frame at the lower hook of the center frame.

- Insert the M6*70 bolt to the Main Frame and Stand Hook.
- If the M6*70 bolt was not inserted, the Main Frame would fall or be damaged.

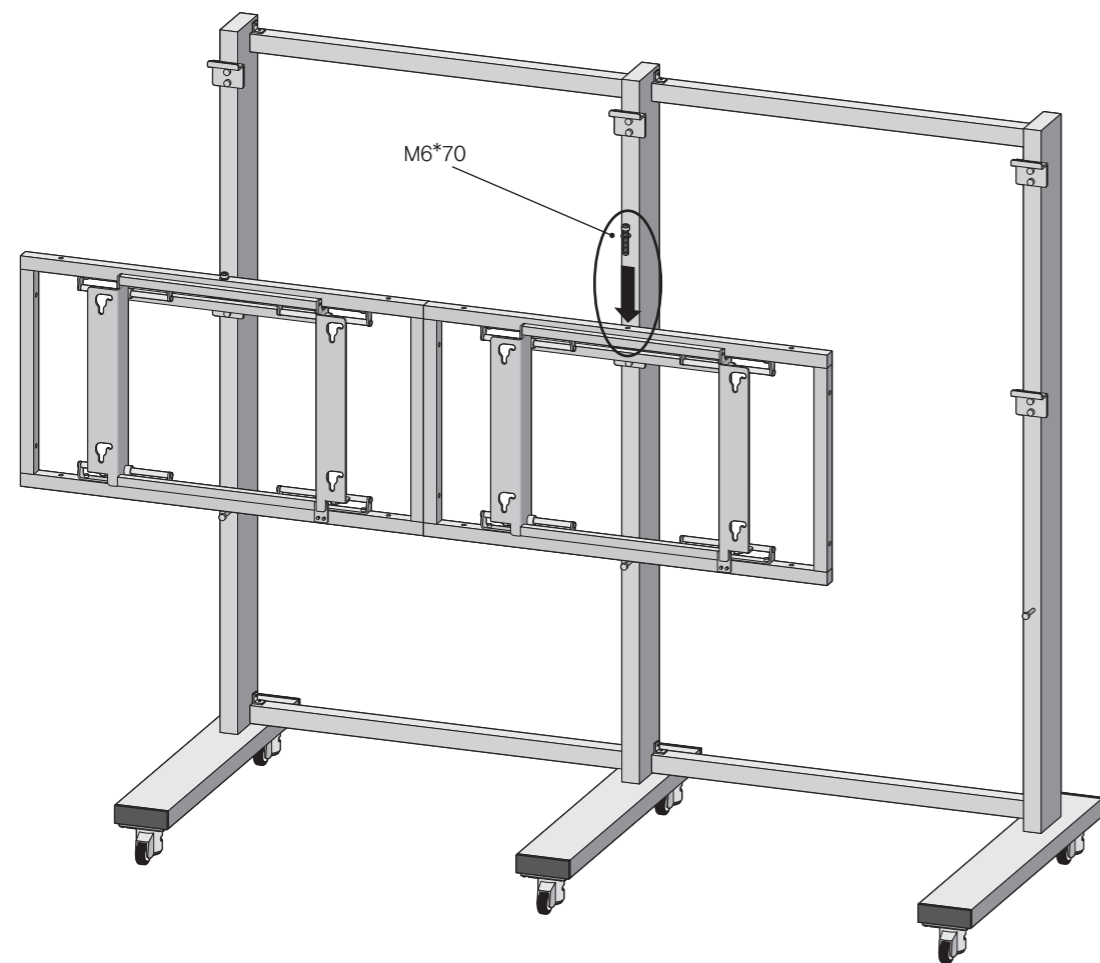

4 Assemble the two Main Frames.

- Assemble the two Main Frames at the upper and lower parts with the M6*70 bolt using the enclosed wrench and 5mm allen wrench.

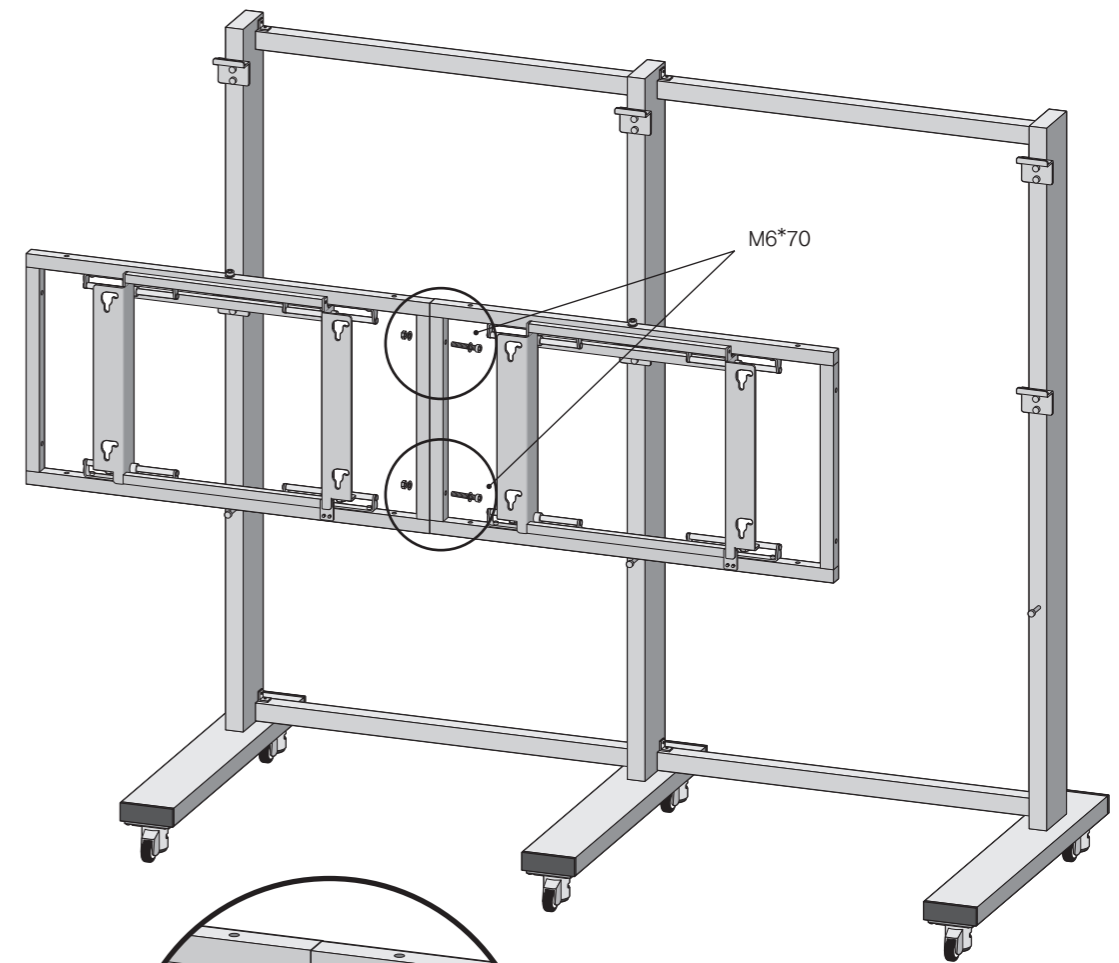

Assemble the figure using the enclosed wrench and 5mm allen wrench.

5 Hook the 3rd Main Frame at the bottom row to the Stand Hook.

- Hook the Main Frame to the Stand Hook and assemble using a wrench and 5mm allen wrench.
- Make sure that the Main Frame is securely assembled when working.

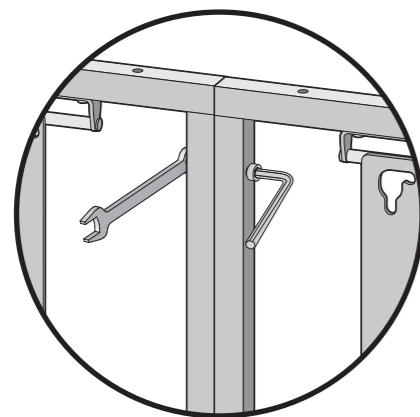
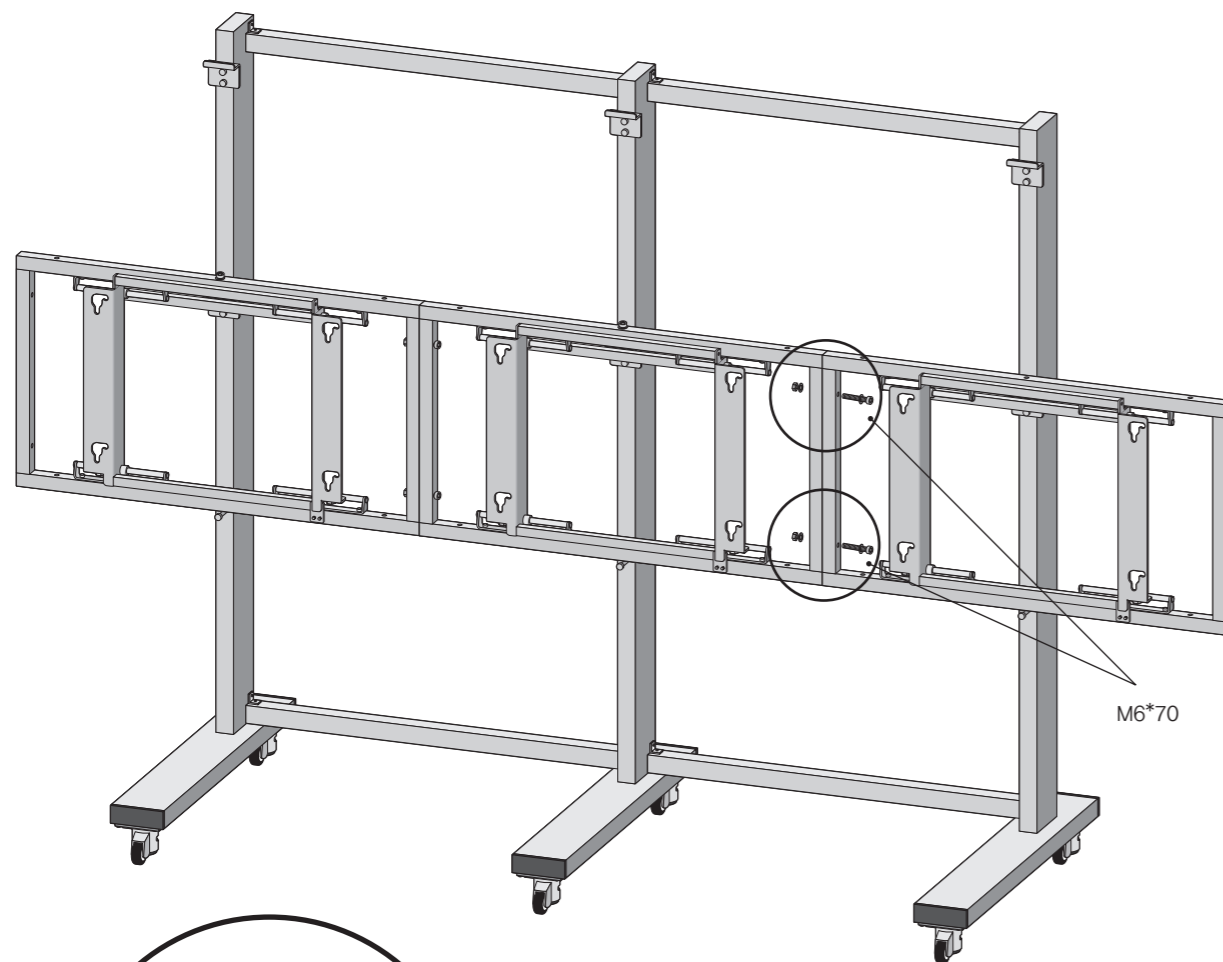

Assemble the figure using the enclosed wrench and 5mm allen wrench.

6 Remove the M6*70 bolt.

- Remove the M6*70 bolts inserted at the 1st and 2nd Main Frames.

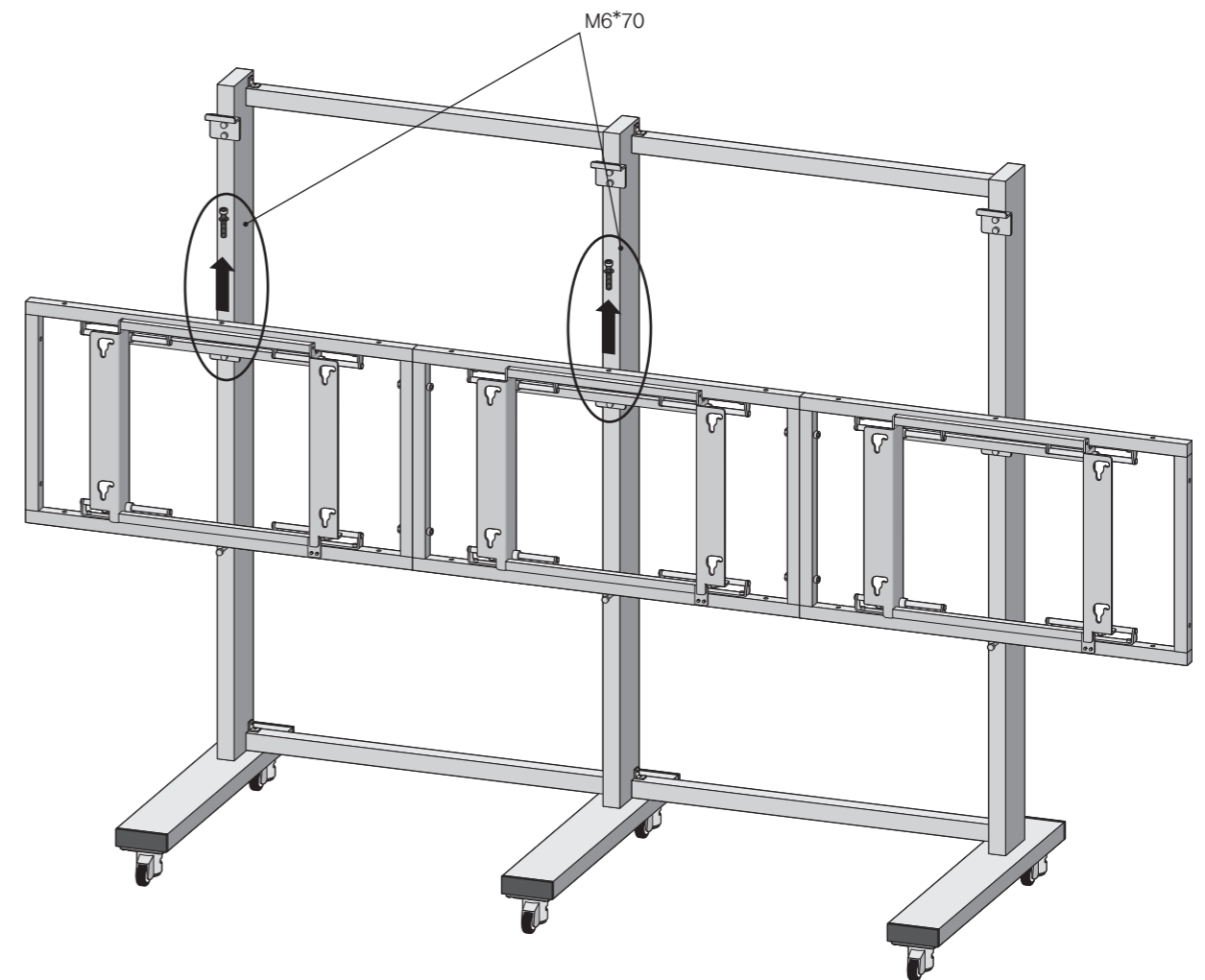

7 Assemble the Main Frame at the 2nd row.

- Hook the Main Frame at the 2nd row to the upper Stand Hook.
- Assemble the Main Frame at the 1st row and Main Frame at the 2nd Row with the M6*70 bolts.

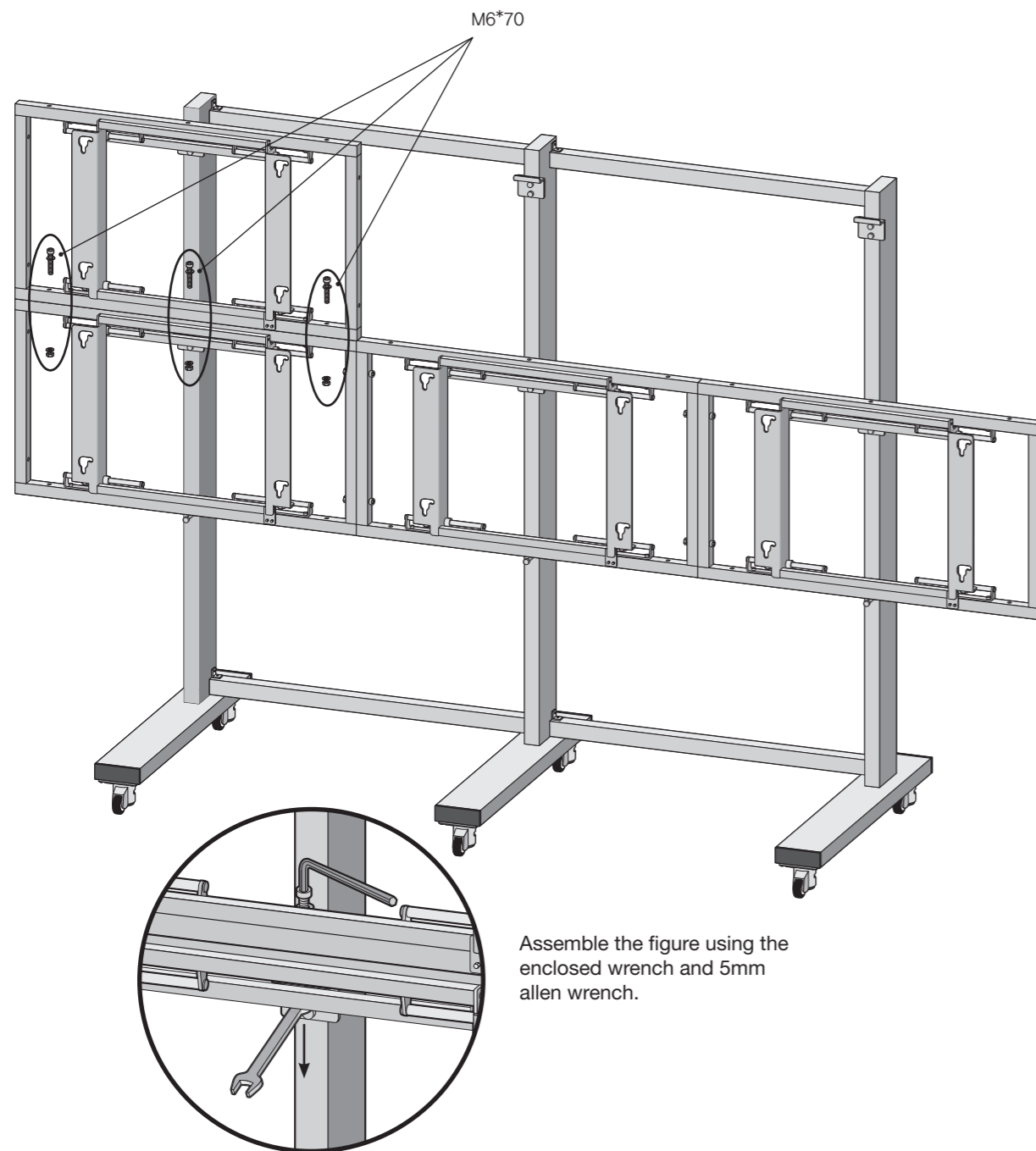

8 Assemble the middle Main Frame at the 2nd row.

- Hook the Main Frame at the 2nd row to the upper Hook.
- Repeat the work indicated in Step No. 7 to assemble the upper and lower Main Frames and then assemble with the adjacent Main Frame with M6*70 bolts.
- Repeat this process to assemble the Main Frame at the 3rd row.

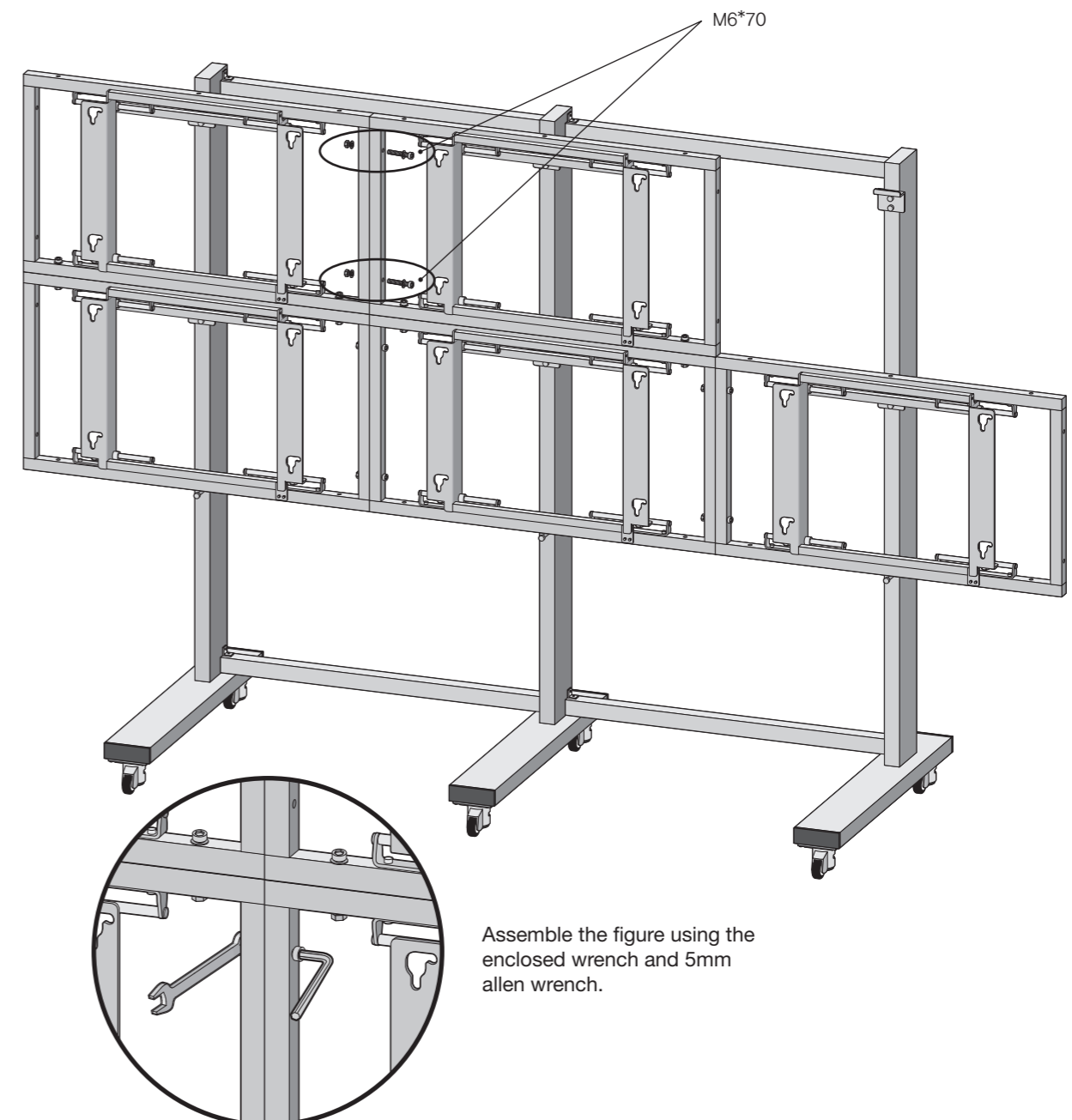

9 Remove the supporting plate of both Main Frames at the vertical axis.

- Once the supporting plate of both Main Frames at the vertical axis is removed, the brackets will move from side to side. Move the vertical axis at both sides to install the MLCD.
- Do not remove the supporting plate of the supporting axis.

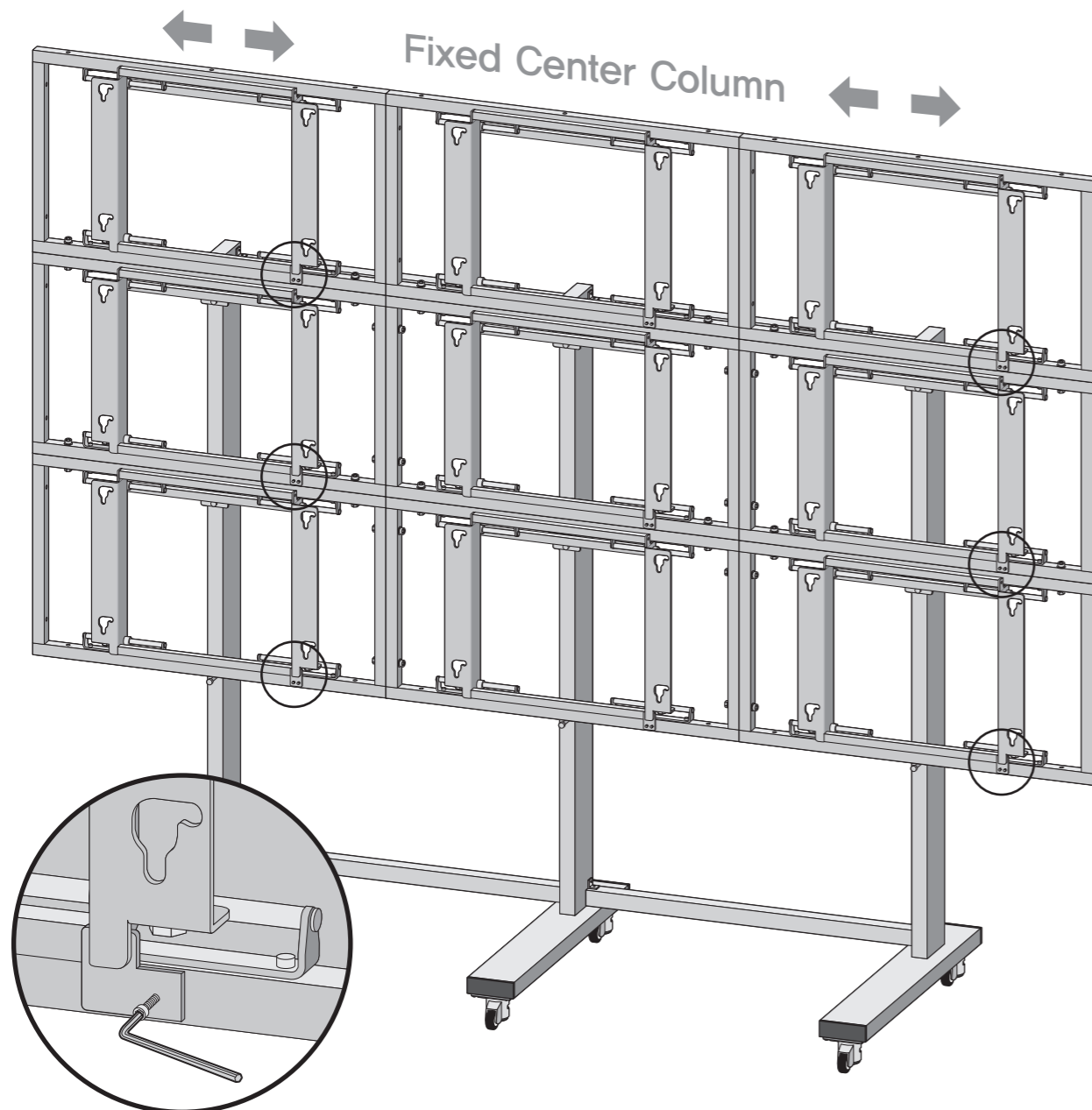

Remove the screws of the supporting plate with a 5mm allen wrench. Then, remove the plate completely from the Main Frame.

10 Fix both rows at the vertical axis as "Y-Axis Link" based on the right side.

- Fix both rows at the vertical axis as "Y-Axis Link" to the right side of the Main Frame bracket for the simultaneous movement of the vertical axis.

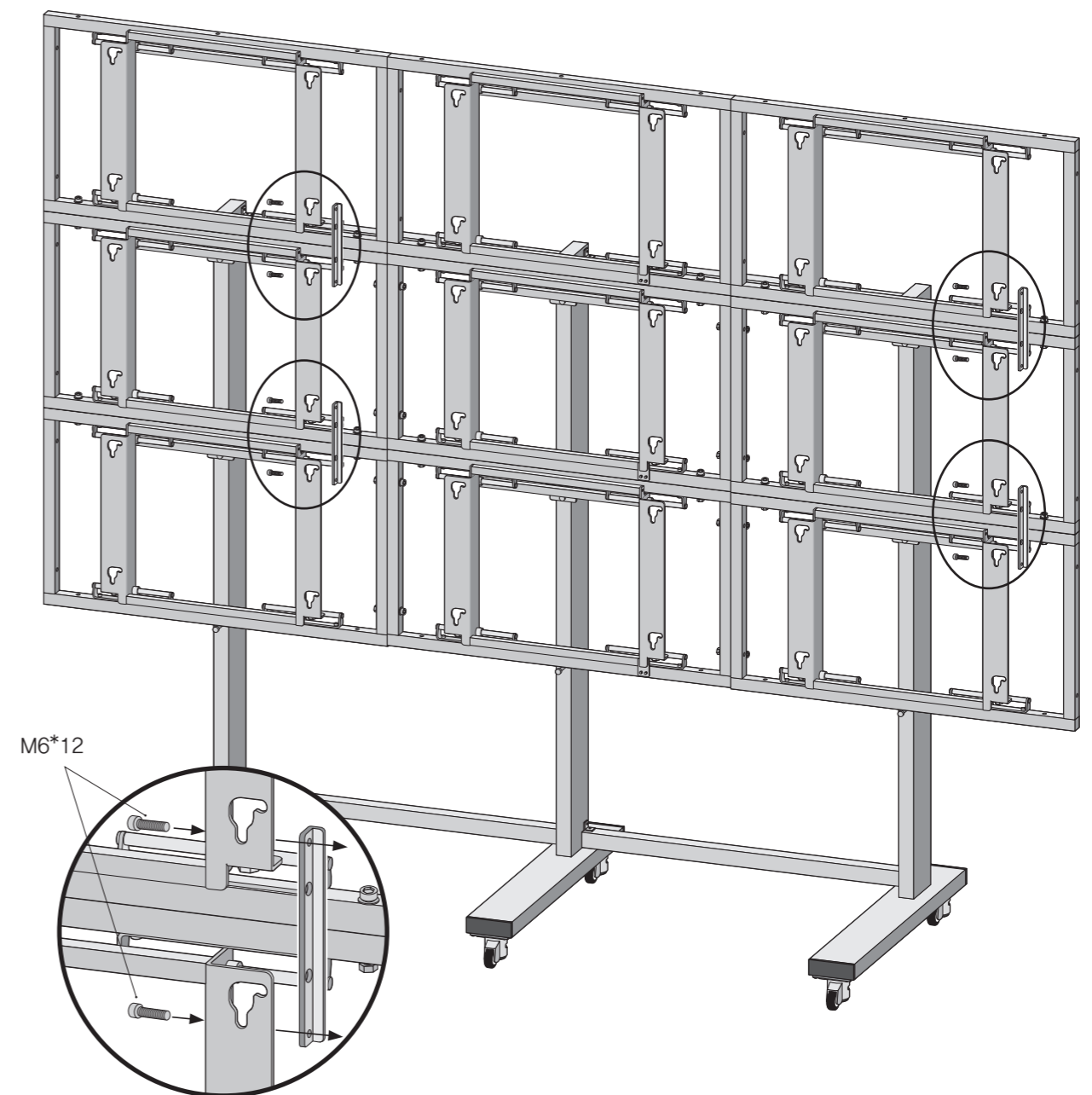

Connect the Main Frame and Y-Axis Link with M6*12 bolts using a 5mm allen wrench.

3. Installing the MLCD

1 Attach the PEG and Guide Pin to the MLCD.

- Assemble the four PEGs at the back of MLCD.
- Install the Guide Pins where MLCD touches.

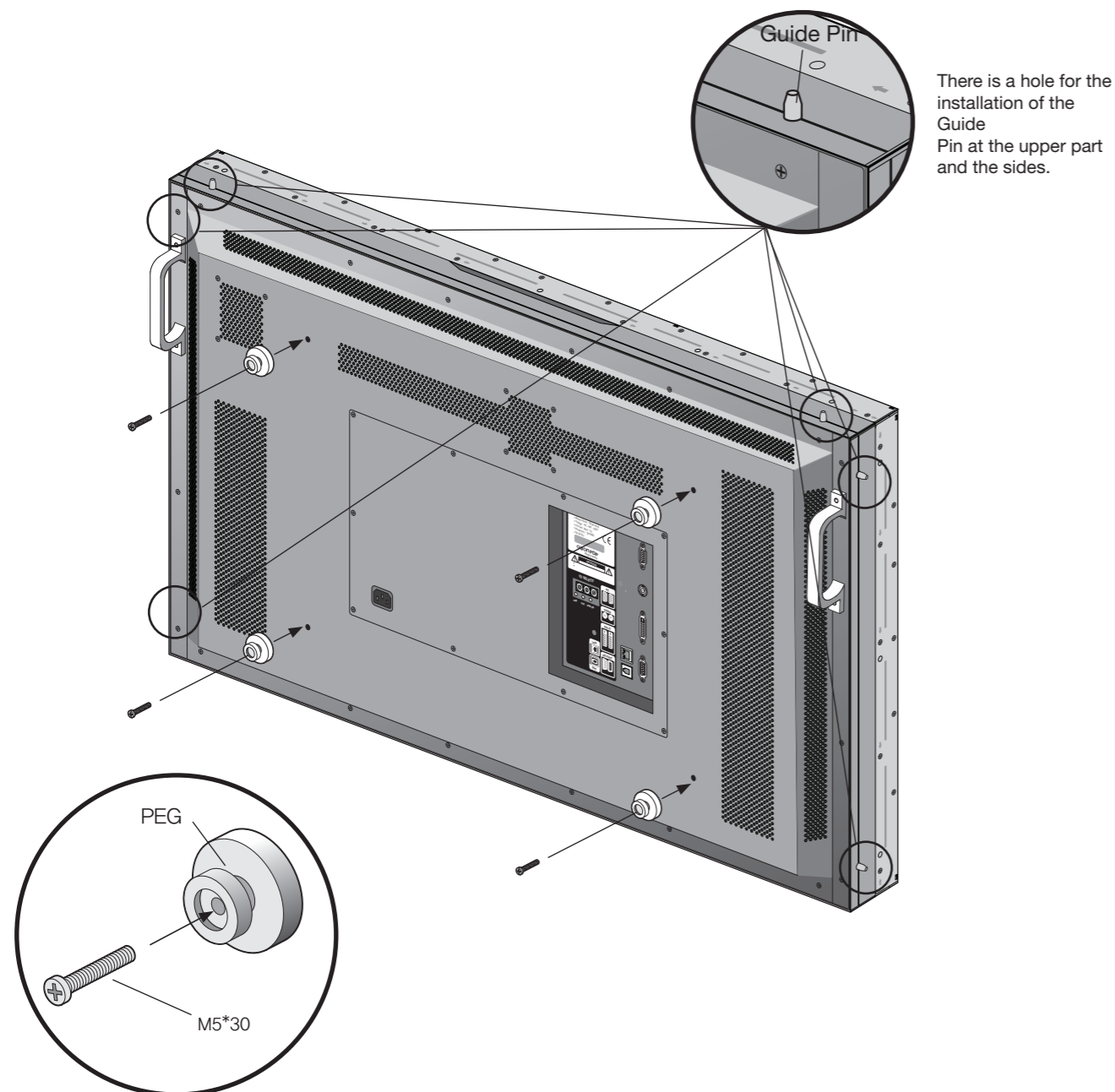

Fasten 4 PEGs in the back of MLCD with M5*30 bolts.

2 Install the MLCD from the lower part of the middle set.

- Insert the PEGs in the PEG holes.
- Put the set down slowly. The panels can be damaged by impact.
- Install the MLCD from the bottom of both sides after completing the installation at the lower middle part.

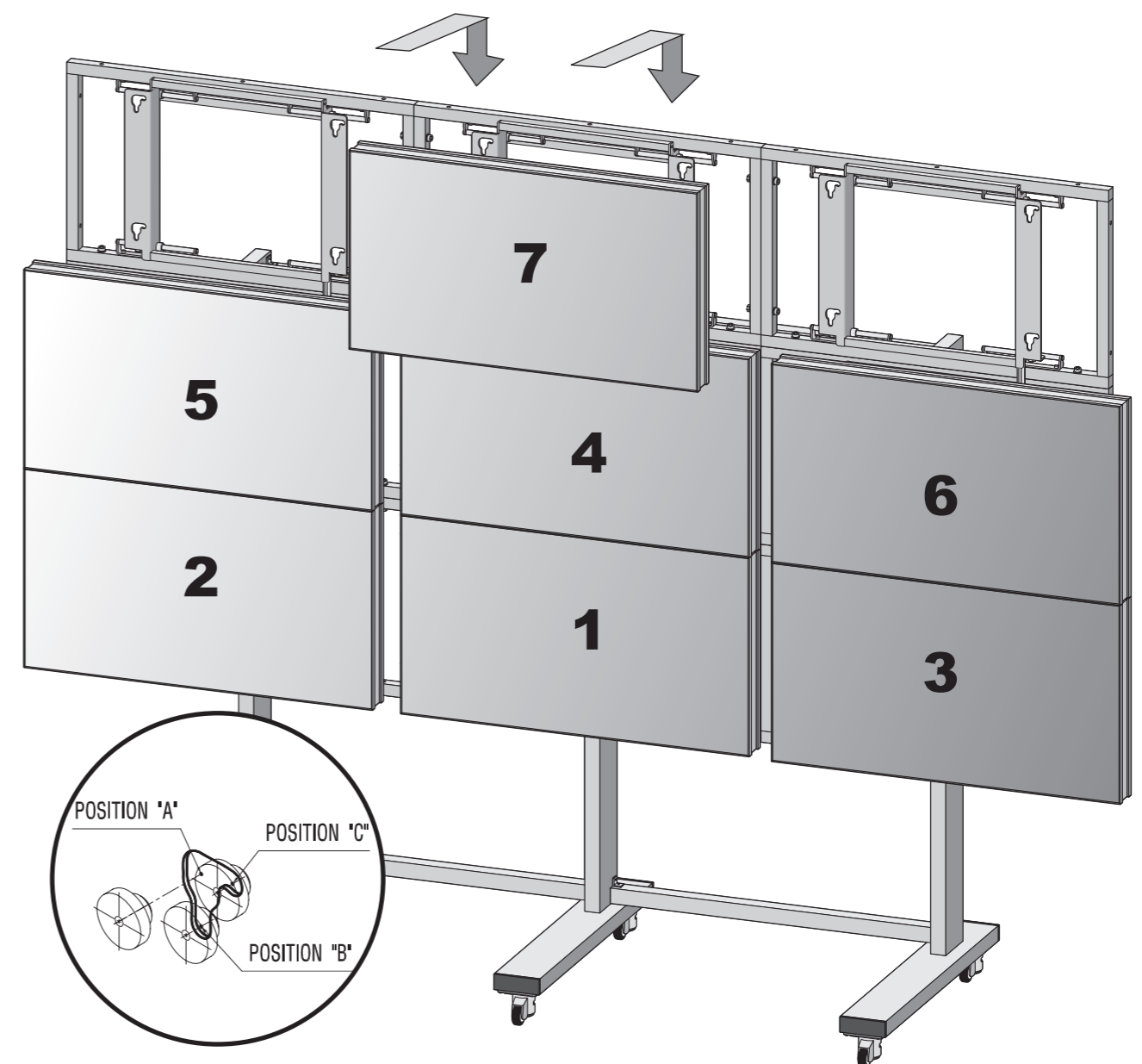

If you need to detach a MLCD set in the lower line, move the set in the upper line to position "C". Remove guide pins from the set in the lower line, move it to position "A" and detach from the main frame.

3 Fix the set by pushing towards the supporting plates

- Install the "FIX BRACKET unit" of both sets at the vertical axis by pushing towards the supporting plates at the central area.
- FIX BRACKET unit is manufactured basically for OLM-4610/OLM-4650. The other models need to detach EXTENSION BRACKET from FIX BRACKET unit to install.

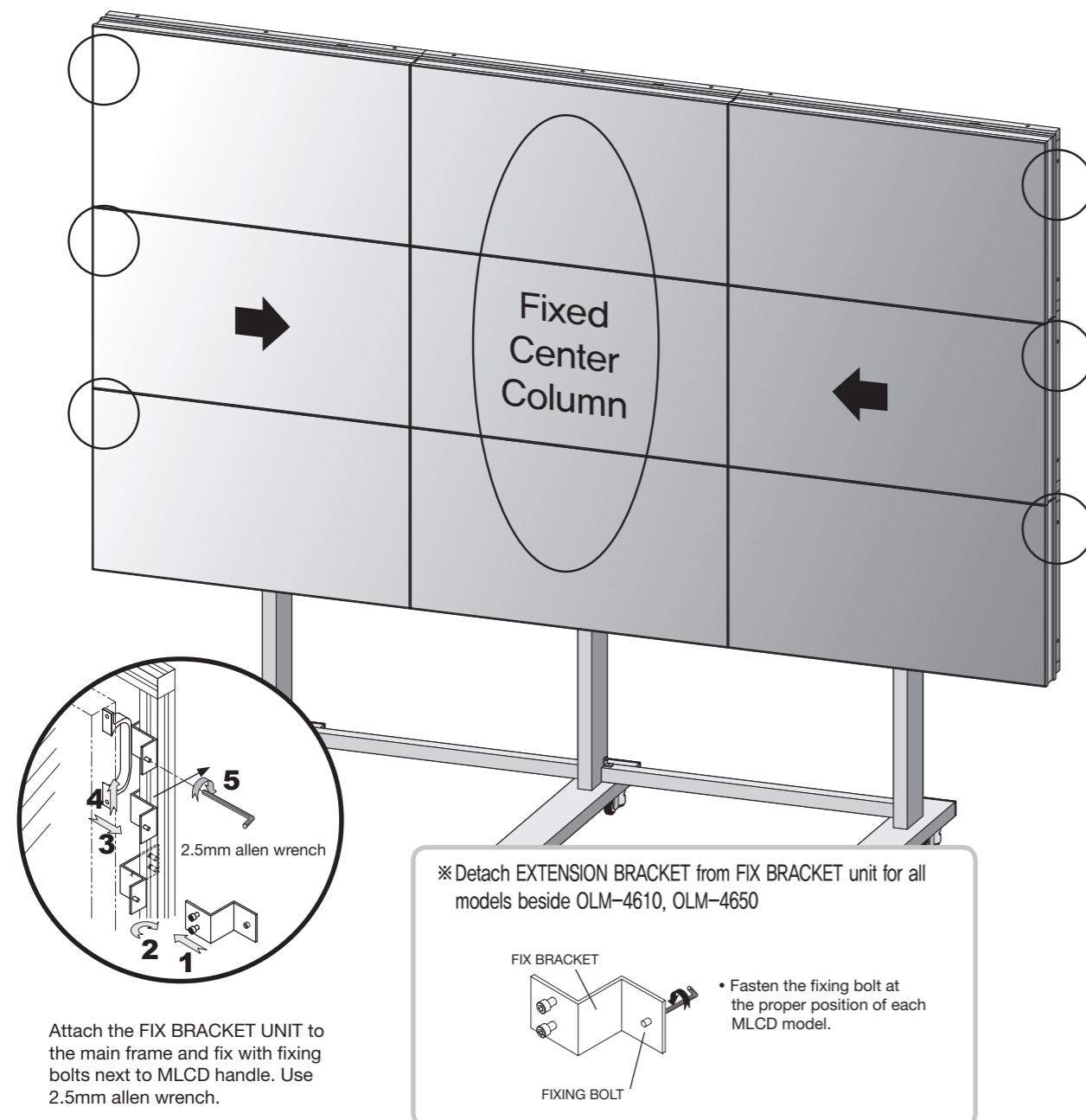

4. Adjust the MLCD gap with the Adjuster.

The gap of the MLCD can be fixed using the Adjuster.

- To fix the gap detected between the MLCD or when the MLCD is tilted after the installation, use the Adjuster.
- Install the Adjuster at the lowest part of the Main Frame using the 5mm allen wrench.

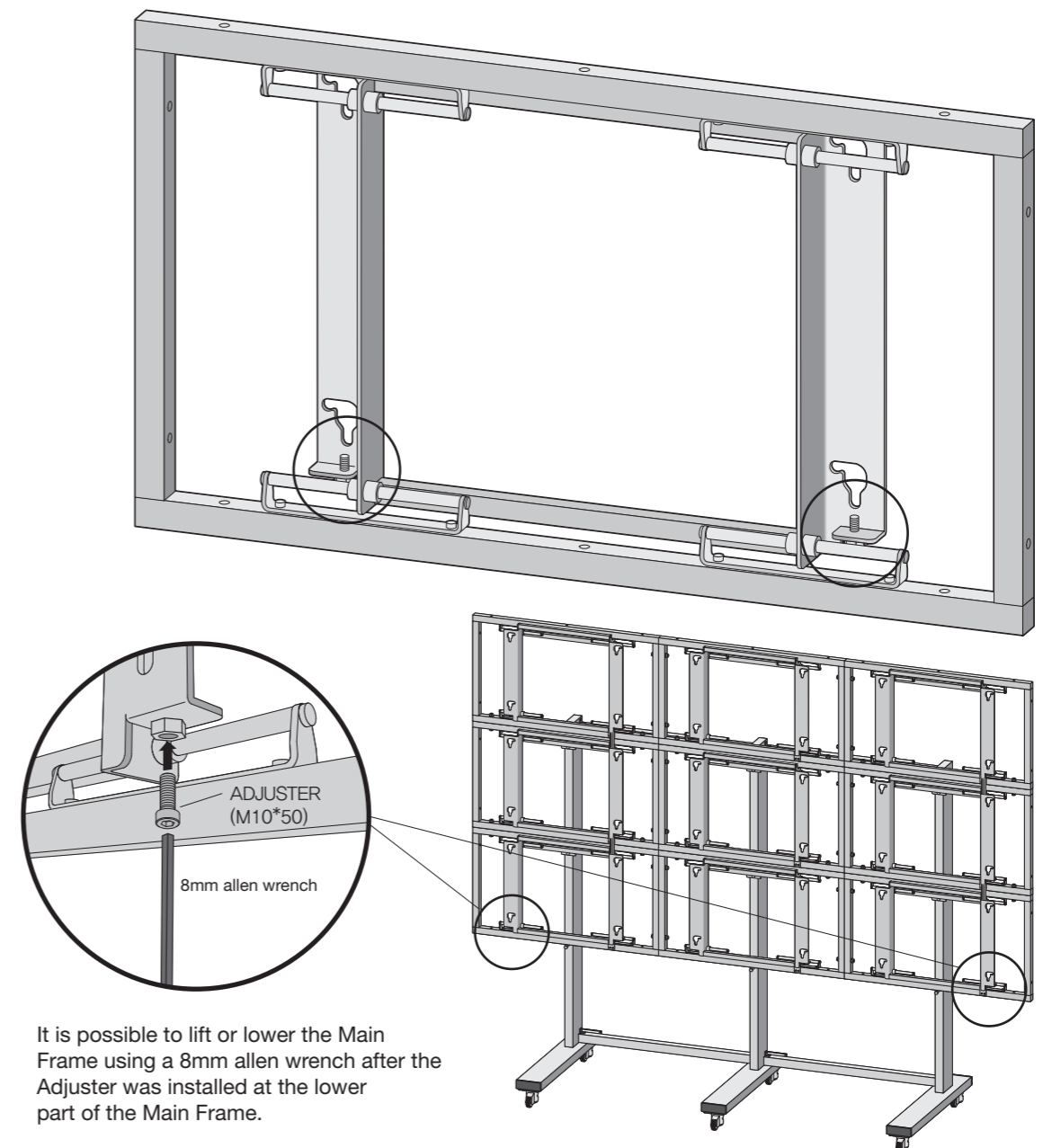

5. Setting MLCD ID configuration and Connection (3X3)

Configure MLCD ID and make connections for all the necessary external devices and power.

- Configure MLCD ID as shown in the following figure.
- Make necessary connections such as VCR, PC and power, etc and finish configuration.
- Neatly arrange all the connection cables. If they are stretched out or disorganized, it may cause personal injury or bad connection.

*** For more information for ID configuration and connection, please refer to MLCD user manual.**

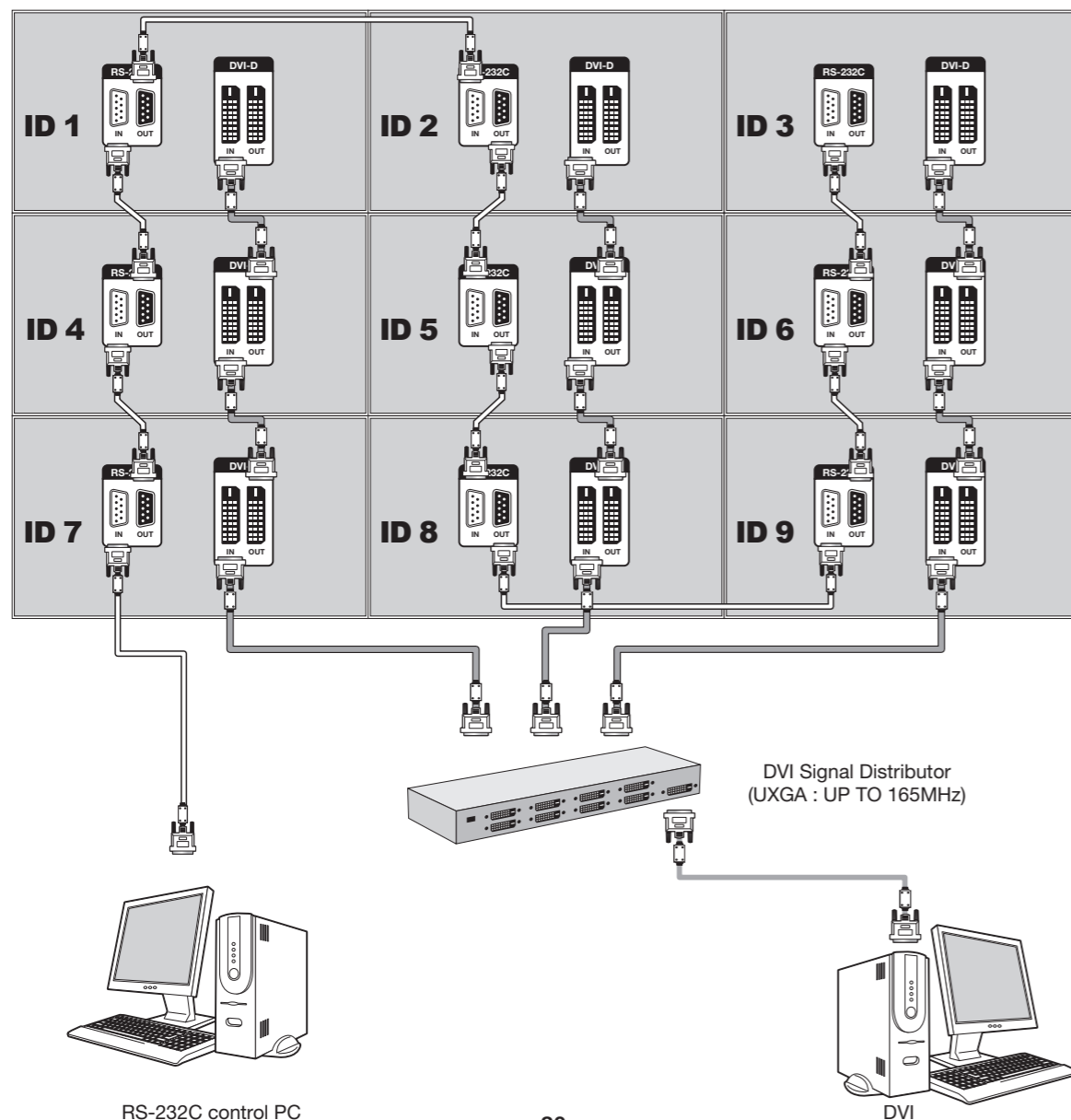

RS-232C control PC

WALL UNIT

*** This manual describes the installation for 3X3 sets.
Apply following instruction according to the number of MLCD sets as you need.**

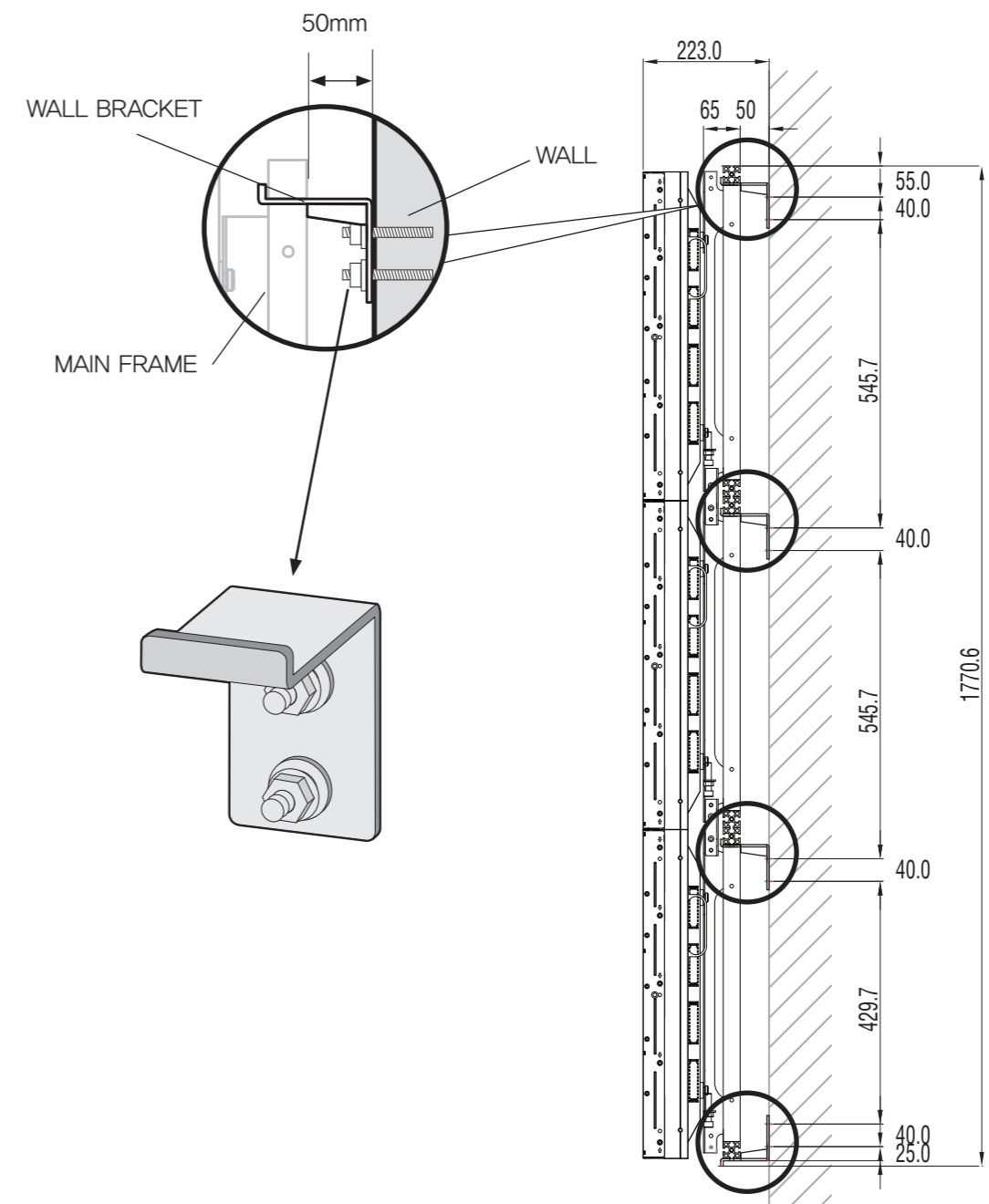

1. Safety Precaution

- * Please read and understand this manual fully before installation.
- * Please handover this manual to customers after installation and ask to read and keep this manual for future use.
- * Please keep all the cautions and warnings for proper use of the product and prevent possible accident or hazard.
- * You can find "CAUTION" and "WARNING" signs in this manual. Each sign has following meaning.

WARNING If the user does not comply with this instruction, serious injuries or death can be caused.

CAUTION If the user does not comply with this instruction, minor injuries or product damage can be caused.

WARNING

Installation must be done by the skilled persons designated by sales agent or dealership.
 Installation work can be very dangerous for inexperienced person.
 It may cause serious injury or even death.

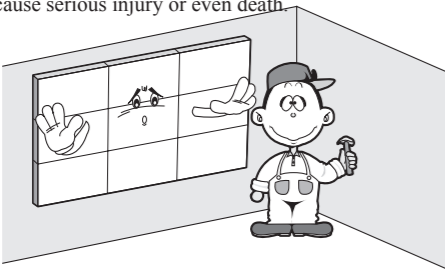

Avoid weak or unstable locations.
 MPDP sets may fall, if the location of installation cannot withstand the weight of MPDP sets.
 It may cause personal injury or product damage.

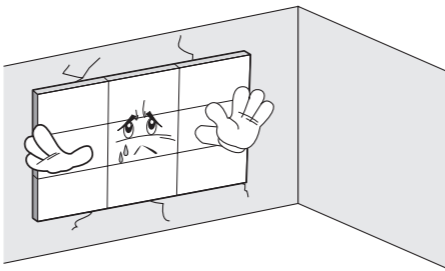

When you need to move or replace the product after installation, contact with the skilled persons designated by sales agent or dealership.
 Installation work can be very dangerous for inexperienced person.
 It may cause safety problems.



Do not hang on the product or give any impact.
 Product may fall and cause person injury.



CAUTION

Please install as described in this manual.
 Improper installation may cause serious injury or product damage.

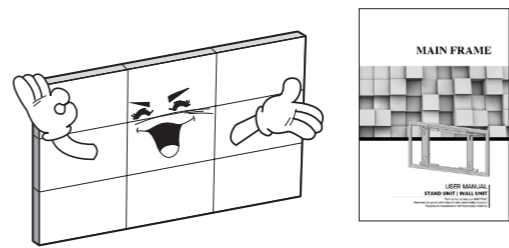

Installation of this product needs 6 or more skilled people.
 6 or more people need to work together to avoid personal injury or product damage.

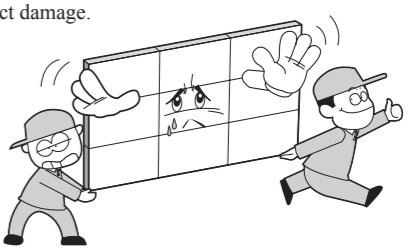

Check the condition and type of wall before installation. If all the condition fits, use enclosed anchors and bolts.
 Unauthorized anchors and bolts may not withstand the weight of the product and may cause safety problems.

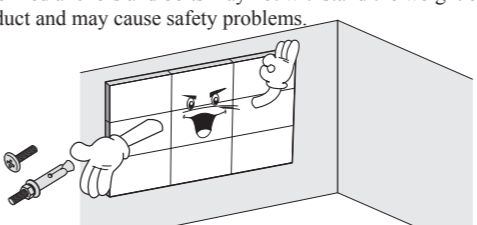

Make sure to use the drill and bit of specified diameter. Follow the instruction for the depth of the hole, too.
 Unspecified way of drilling may cause unstable installation. It may cause safety problems.

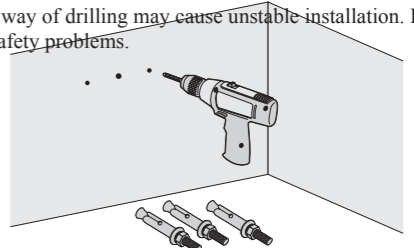

Do not use heaters or humidifiers at the place of installation.
 Heat or vapor may cause fire, electric shock or malfunction.

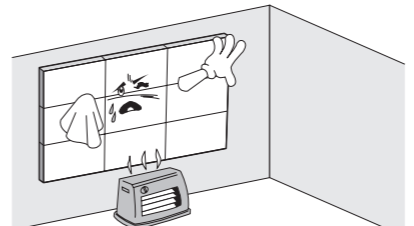

Do not install the product near to sprinkler, fire detector, high-voltage cable, power source, or places of vibration or impact.

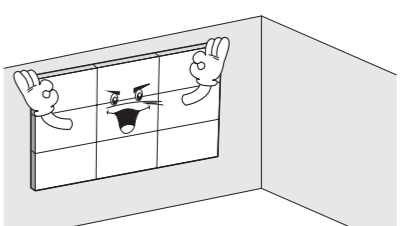

Make sure to disconnect power cord before installation.
 If you install the product while the power cord is still connected, it may cause electric shock or fire.

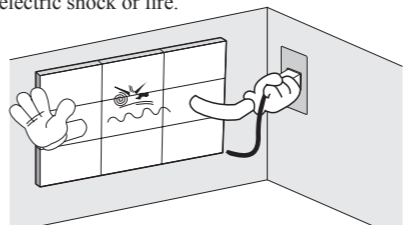

Use working gloves when you install.
 Wear working gloves to avoid any injury.



2. Checking the location for installation.

Check the type of wall to examine whether it can withstand the weight of product.

- Check the type and thickness of wall and the finish material.
- Check the wall can withstand the weight of the product before installation.
- You can use enclosed anchors and bolts, if the thickness of the finish material is 20mm or less.
- Never install the product to the wall of gypsum board.

Check the installation space.

- Select the location suitable for the product size and install to maintain the horizontal and the vertical position.
- Leave some space between the product and wall or other structures. (Minimum 15cm)
- If the product is installed in a closed space, it may be a cause of fire or malfunction for its internal heat.

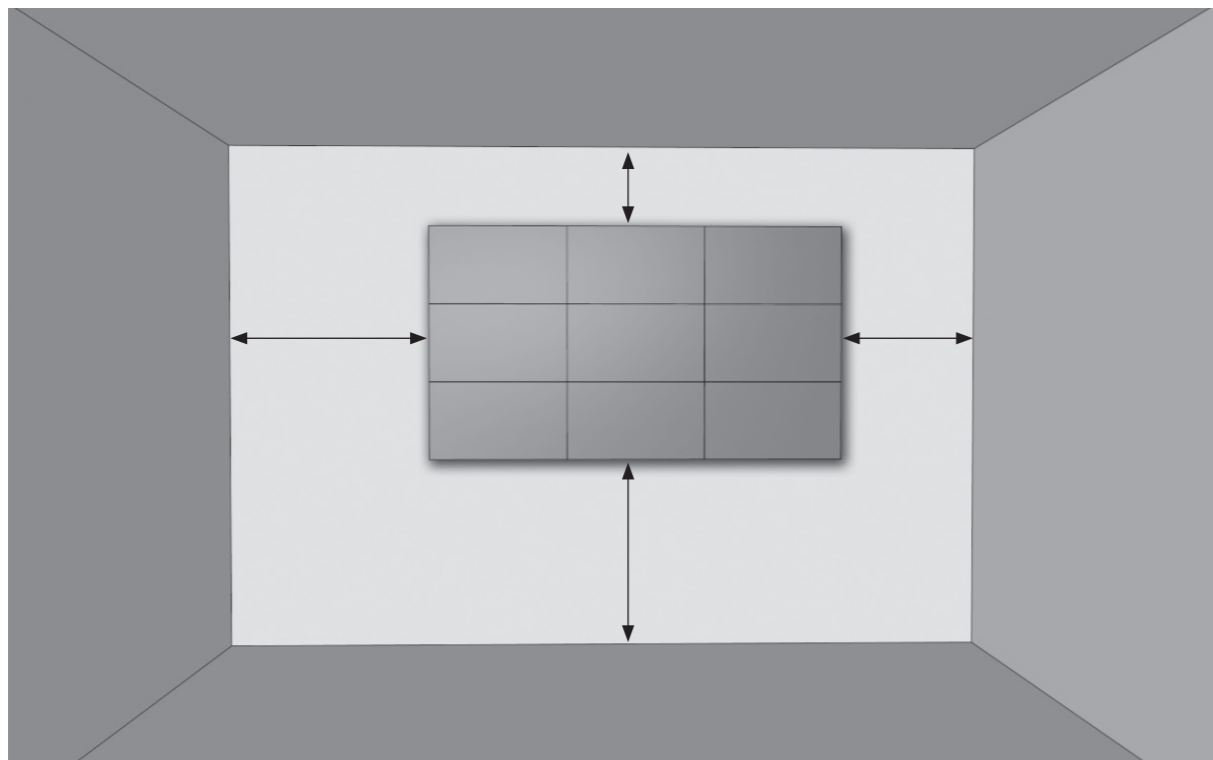

3. Fixing Anchor and Bolt

* Make sure to use specified accessory.

* Check the positions and intervals.

If the hole positions are not accurate, the gap between MLCD sets can be irregular.

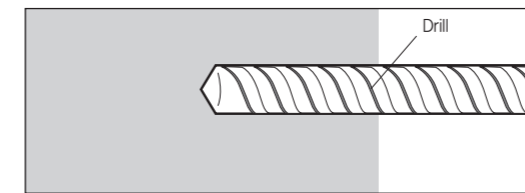

Drill a hole with 8mm of diameter and 80mm~100mm of depth at the anchor spot marked at the wall.

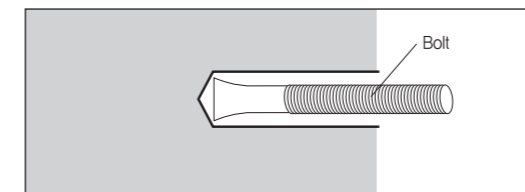

Clean the hole.
Insert the bolt into the hole.

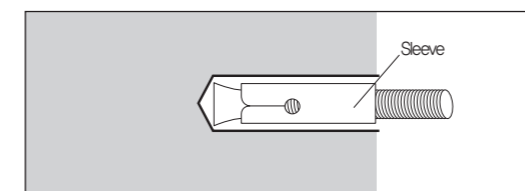

Insert the sleeve along the bolt.

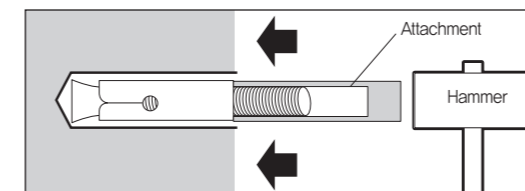

Insert the attachment, and hit it to insert by the hammer.

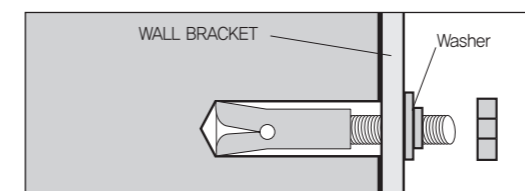

Fix the WALL BRACKET and assemble the washer and the nut.

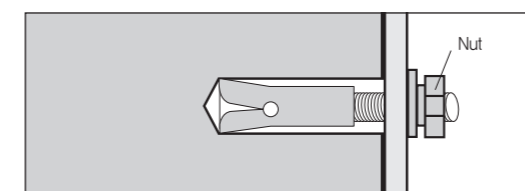

Fasten the nut securely.

4. Installing the Wall Bracket (3 X 3)

1 Install the Wall Bracket.

- Mark the location on the wall where the Bracket will be installed according to the number of set and gap.
- To install the Wall Bracket on the lowest part of the Main Frame, choose two areas at the upper and lower parts for each set. Install the Wall Brackets facing each other at the bottom portion.
- Drill holes where the Wall Brackets will be installed using a drill and install the anchor bolts (3/8"). Attach with Wall Brackets and nuts.
- Make sure that the horizontal and vertical lines are balanced when working.

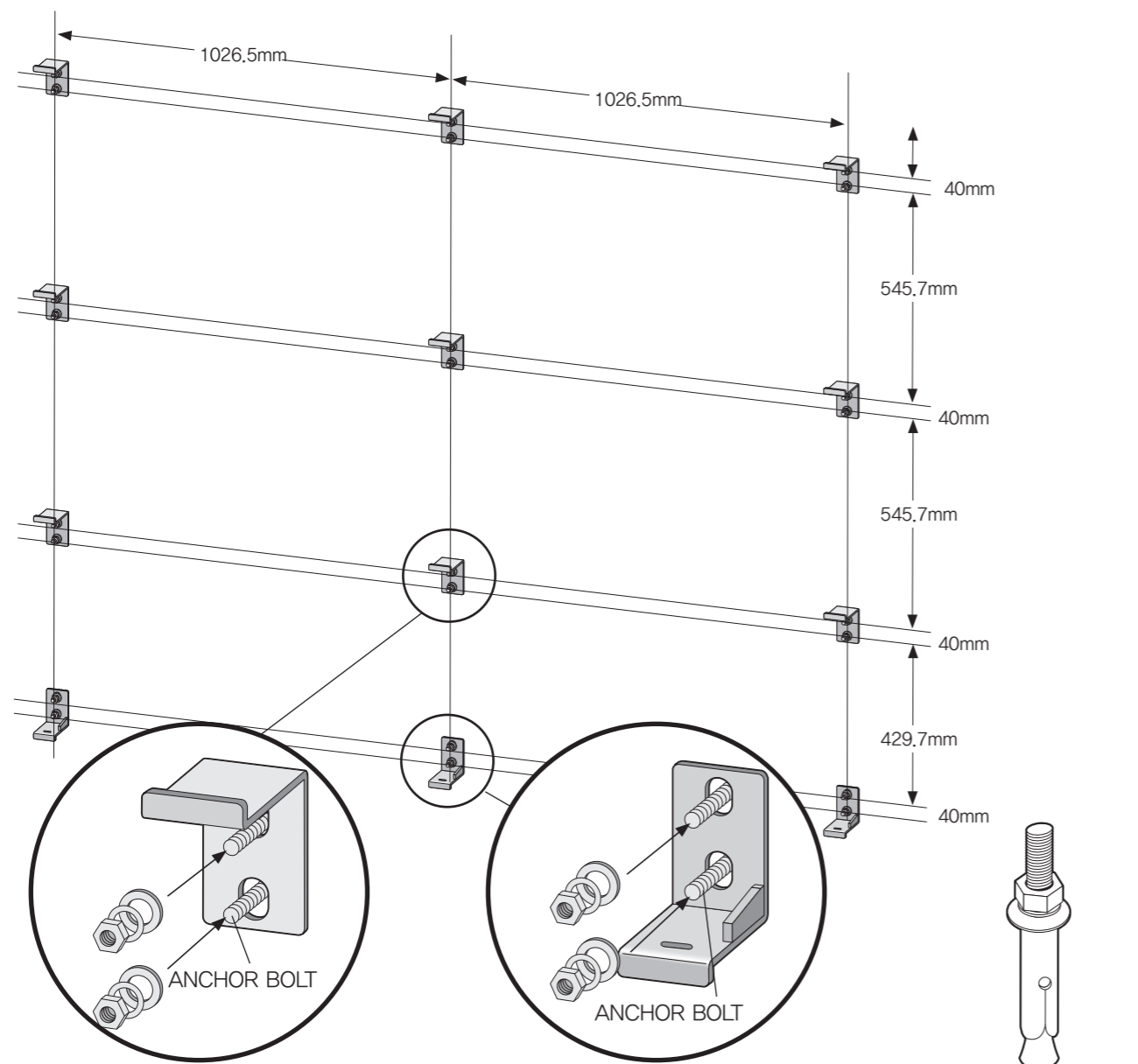

Attach the anchor bolts (3/8") and Wall Brackets into the wall.

Install the Wall Brackets at the bottom facing the upper parts.)

2 Hook the Main Frame at the lower part of the Wall Bracket.

- Assemble the Main Frame starting from the lower to the upper part.
- Insert M6*70 bolts to the Main Frame and the Wall Bracket.
- If the M6*70 bolt was not inserted, the Main Frame would fall or be damaged.

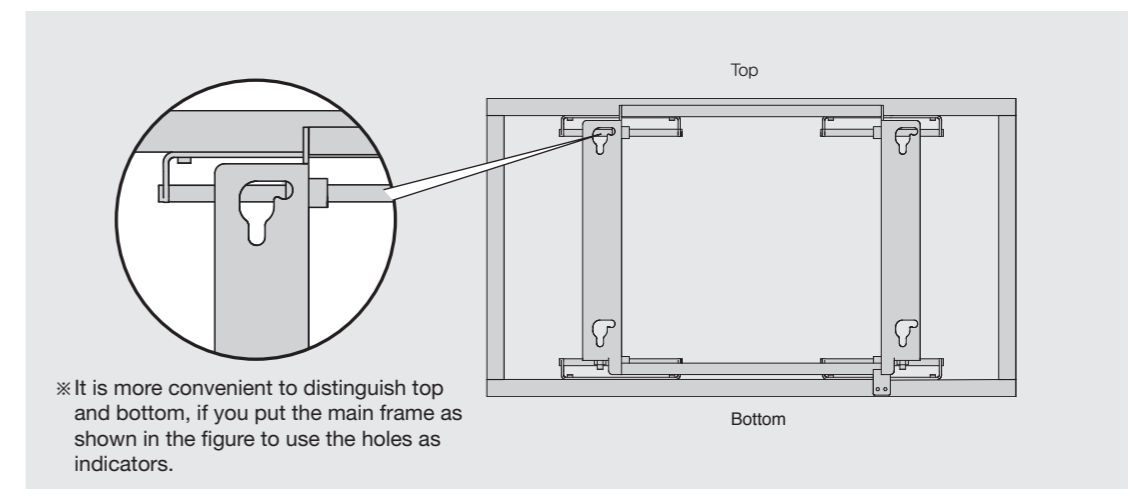
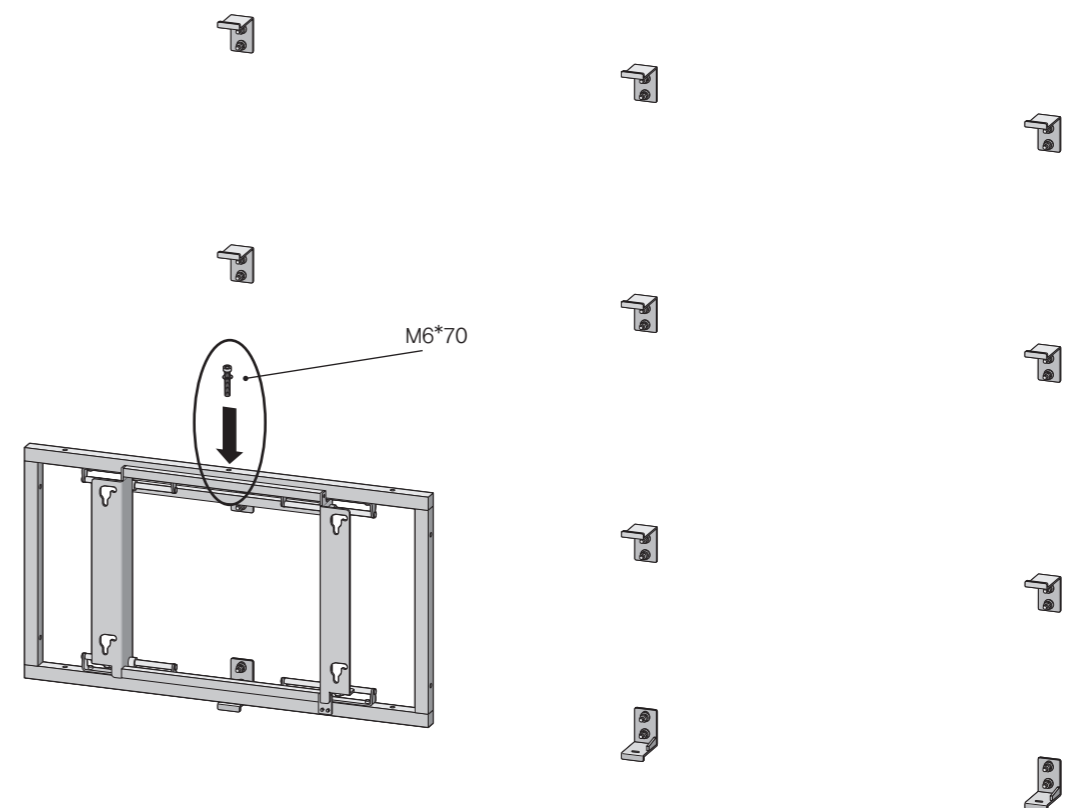

※ It is more convenient to distinguish top and bottom, if you put the main frame as shown in the figure to use the holes as indicators.

3 Hook the 2nd Main Frame at the middle Wall Bracket.

- Insert M6*70 bolts at the Main Frame and Wall Bracket.
- If the M6*70 bolt was not inserted, the Main Frame would fall or be damaged.

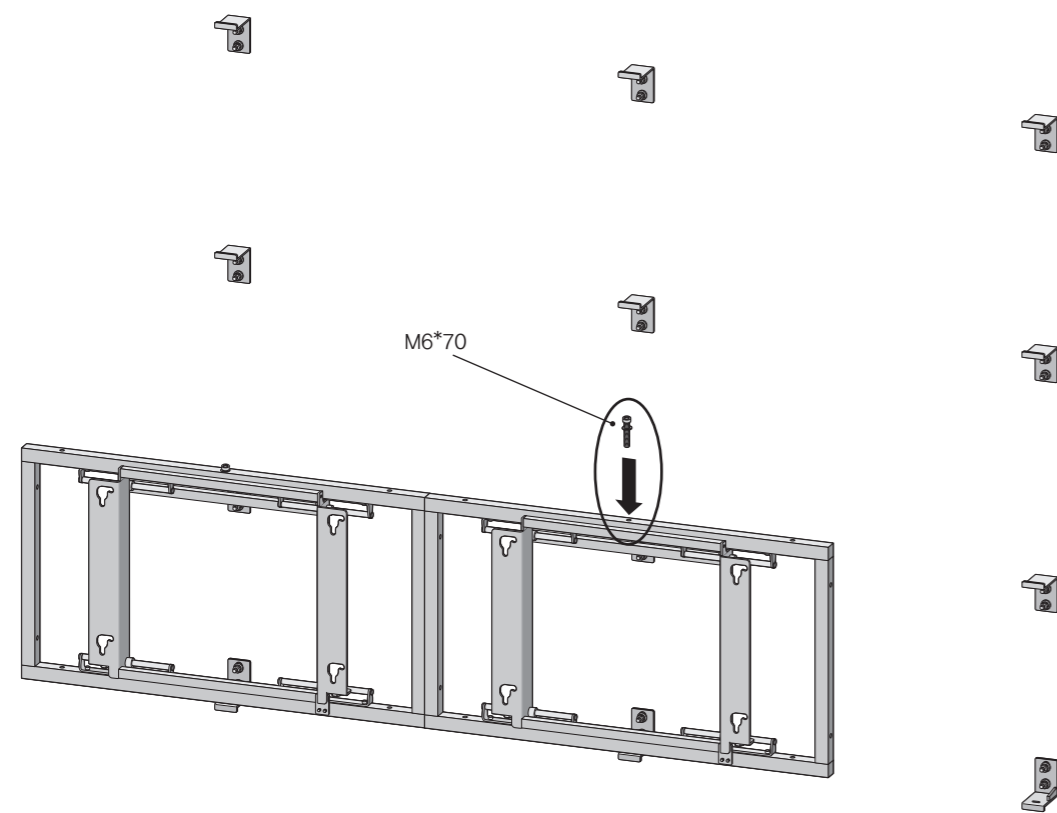

4 Assemble the two Main Frames.

- Assemble the two Main Frames at the upper and lower parts with M6*70 bolts using a 5mm allen wrench.

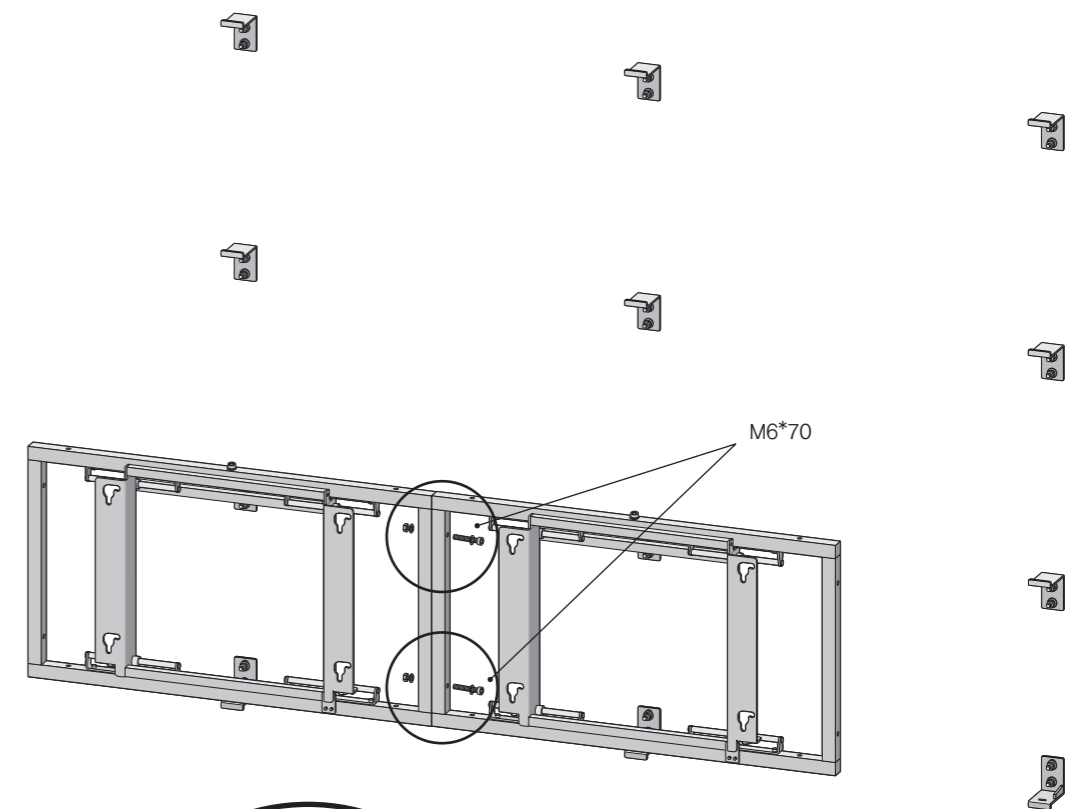

Assemble the figure using the enclosed wrench and 5mm allen wrench.

5 Hook the 3rd Main Frame at the 3rd row from the bottom to the Wall Bracket.

- Hook the Main Frame to the Wall Bracket and assemble it with a wrench and 5mm allen wrench.
- Make sure that the Main Frame is securely assembled when working.

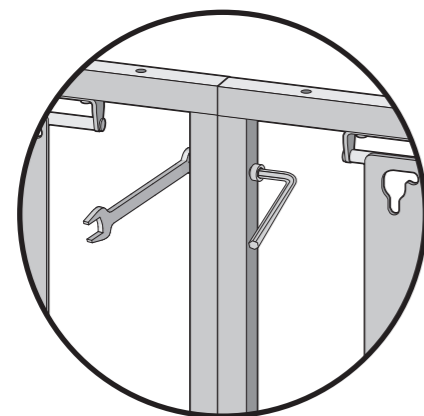
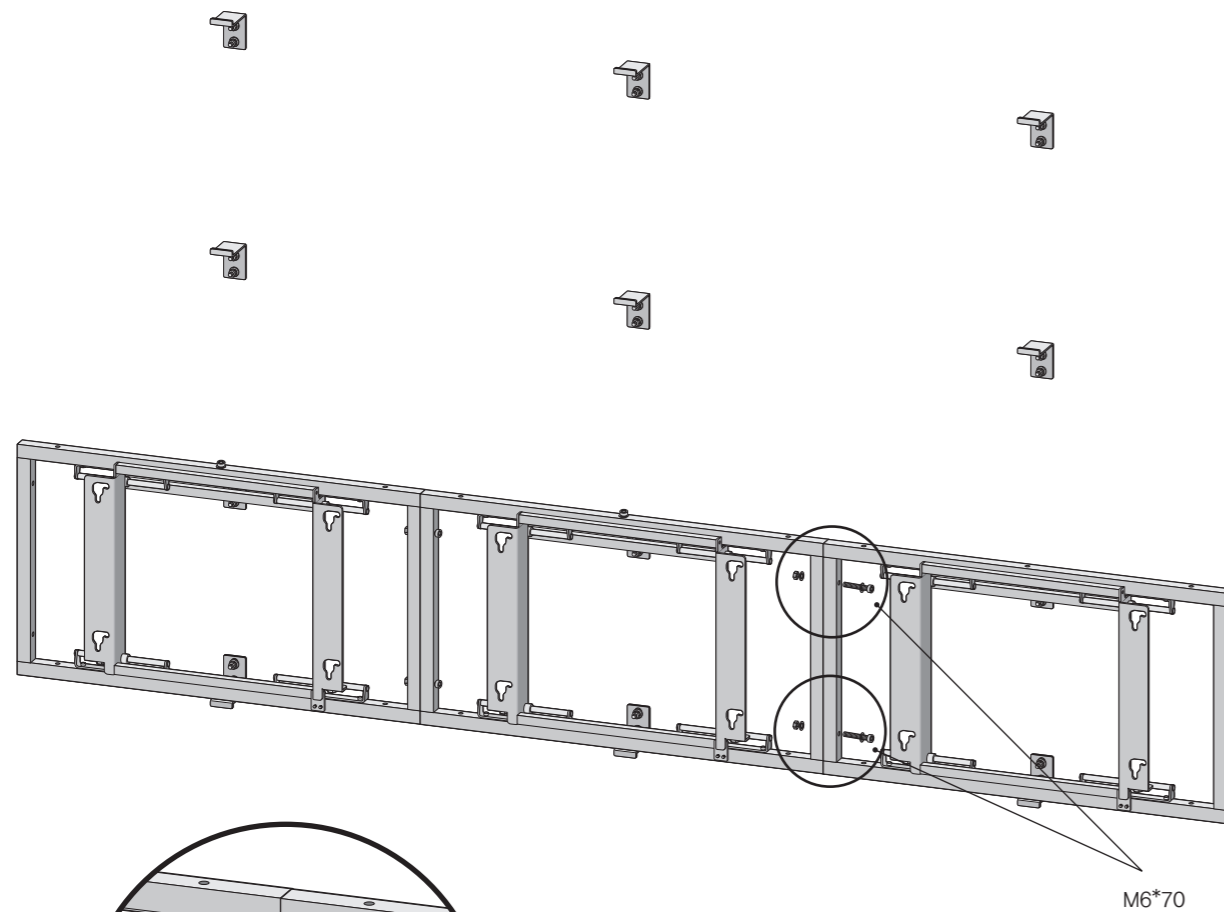

Assemble the figure using the enclosed wrench and 5mm allen wrench.

6 Remove the M6*70 bolts.

- Remove the M6*70 bolts inserted at the 1st and 2nd Main Frames.

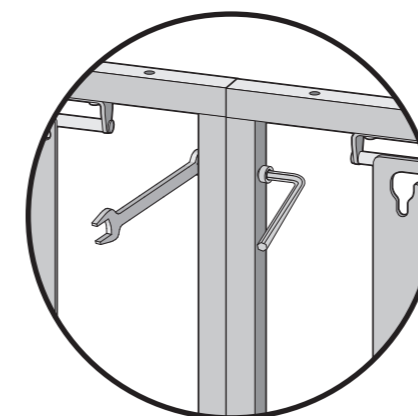
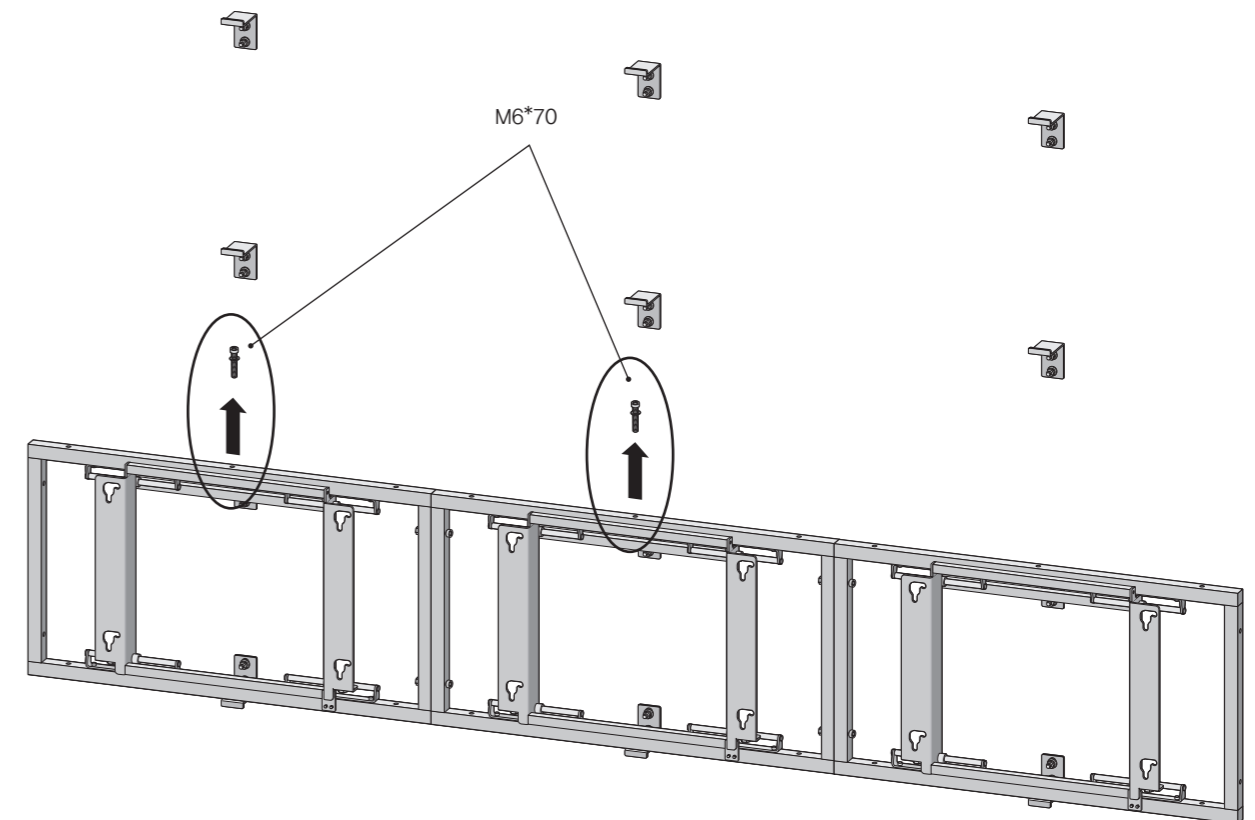

Assemble the figure using the enclosed wrench and 5mm allen wrench.

7 Assemble the Main Frame at the 2nd row.

- Hook the Main Frame at the 1st row to the upper Hook of the Stand.
- Assemble the Main Frame at the 1st row and Main Frame at the 2nd row with M6*70 bolts.

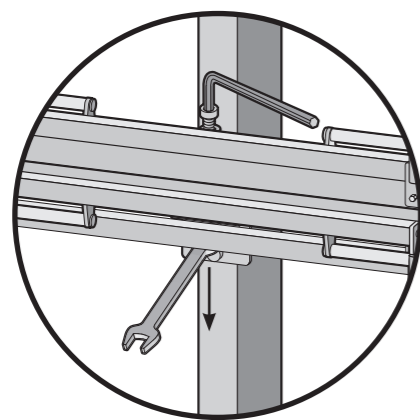
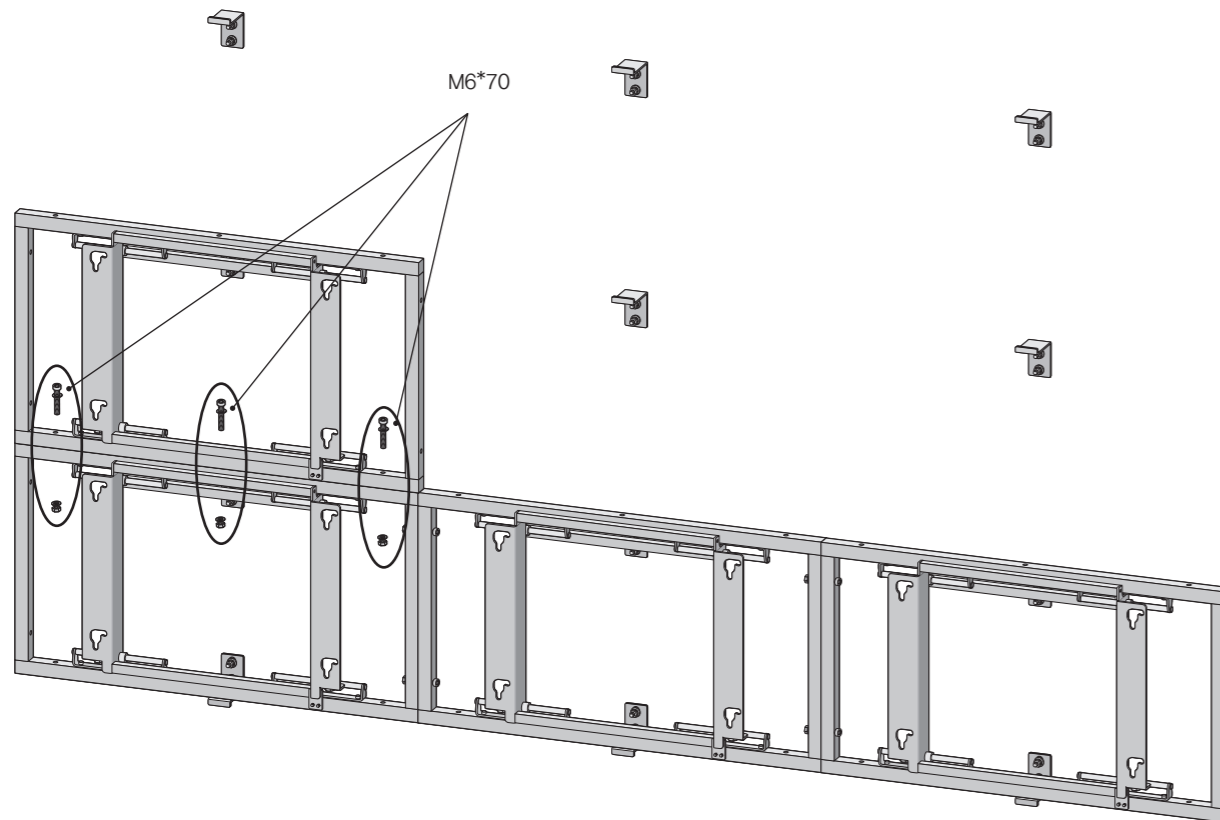

Assemble the figure using the enclosed wrench and 5mm allen wrench.

8 Assemble the middle Main Frame at the 2nd row.

- Hook the Main Frame of the 2nd row to the Wall Bracket.
- Repeat Step No. 7 to assemble the upper and lower Main Frames and then assemble the adjacent Main Frame with M6*70 bolts.
- Repeat this process to assemble the Main Frame at the 3rd row.

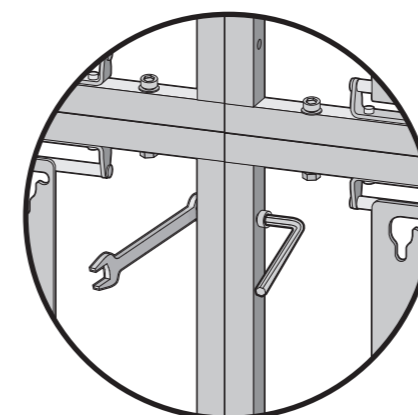
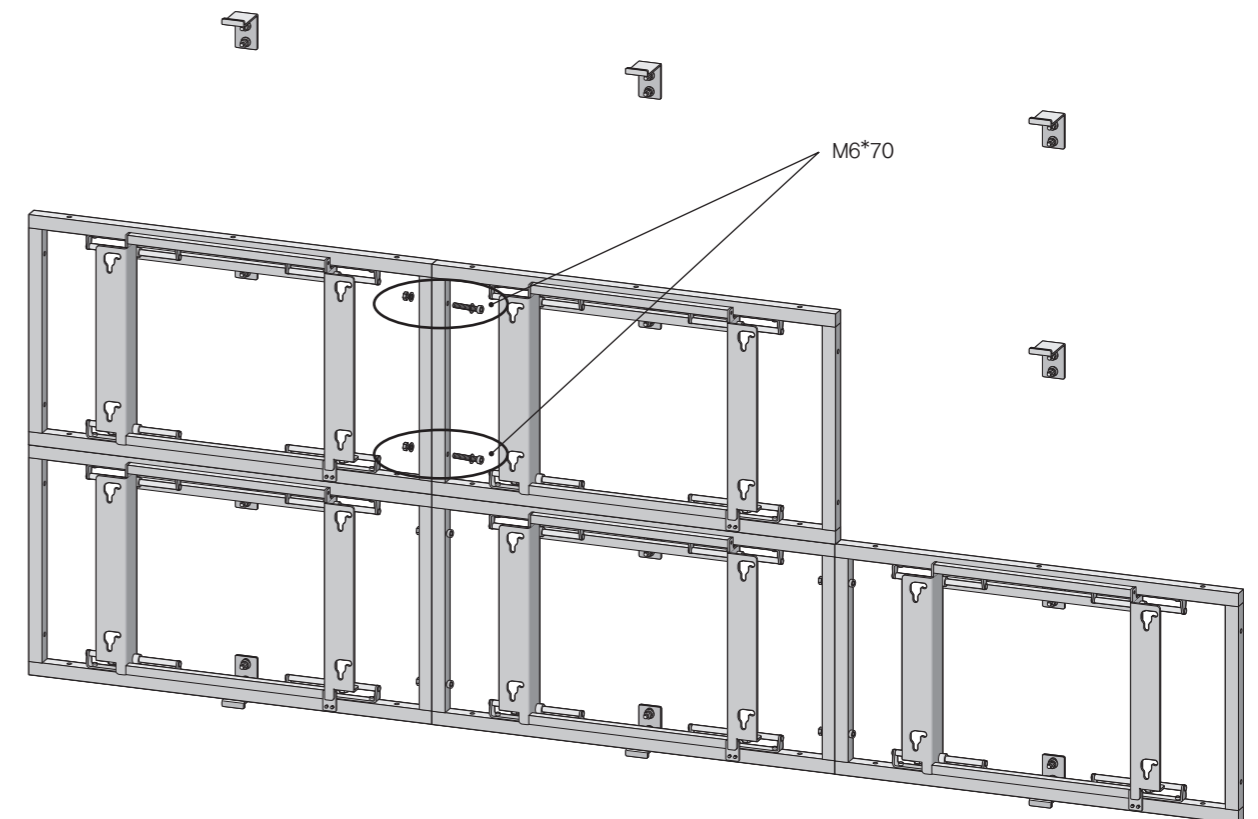

Assemble the figure using the enclosed wrench and 5mm allen wrench.

9 Assemble the upper part of the 3rd row with M6*40 bolts.

- Assemble the Main Frame and Wall Bracket at the upper part and the lowest row with M6*40 bolts.

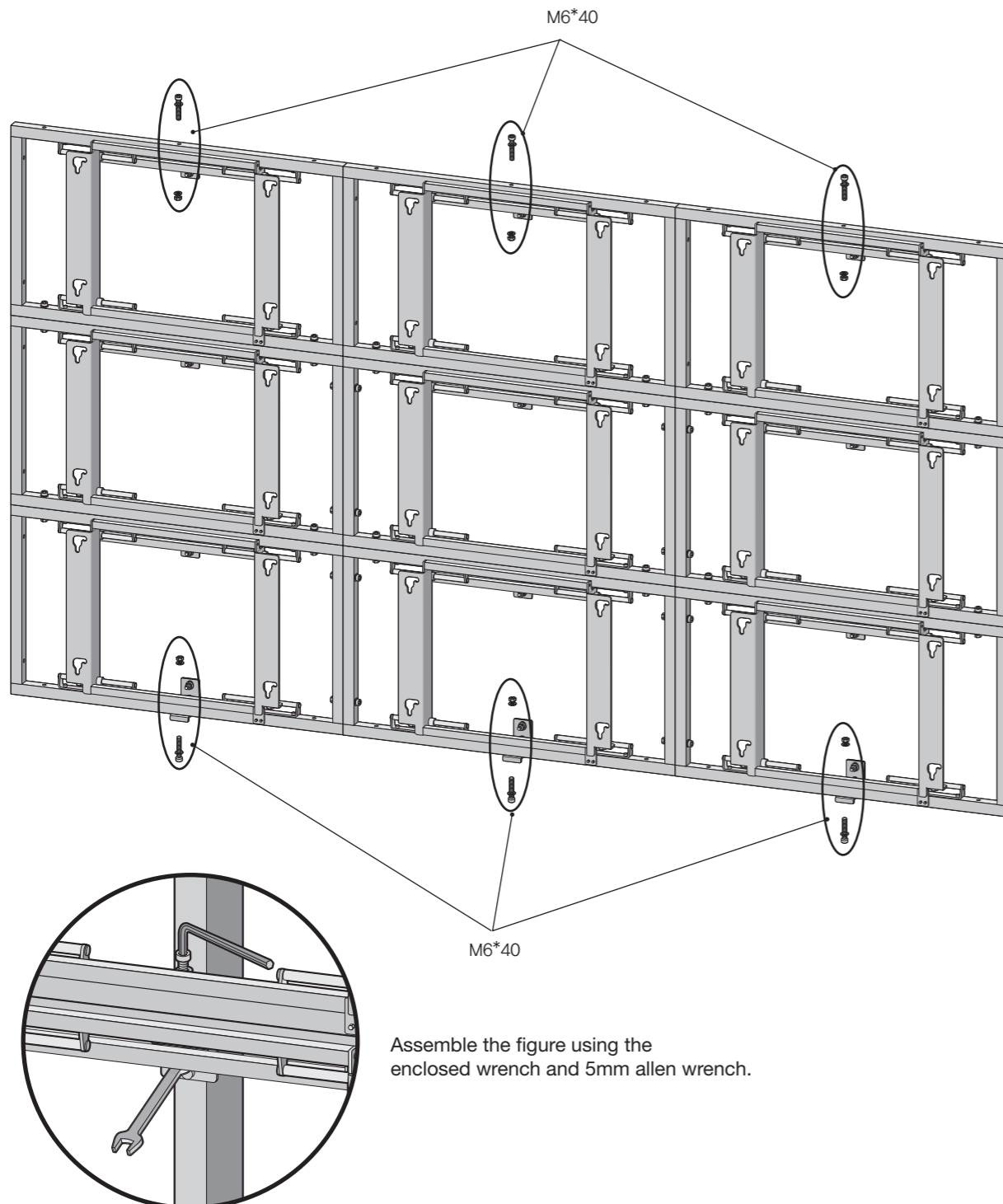

10 Remove the supporting plate of both Main Frames at the vertical axis.

- Once the supporting plate of both Main Frames at the vertical axis is removed, the brackets move from side to side. Move the vertical axis at both sides to install the MLCD.
- Do not remove the supporting plate of the supporting axis.

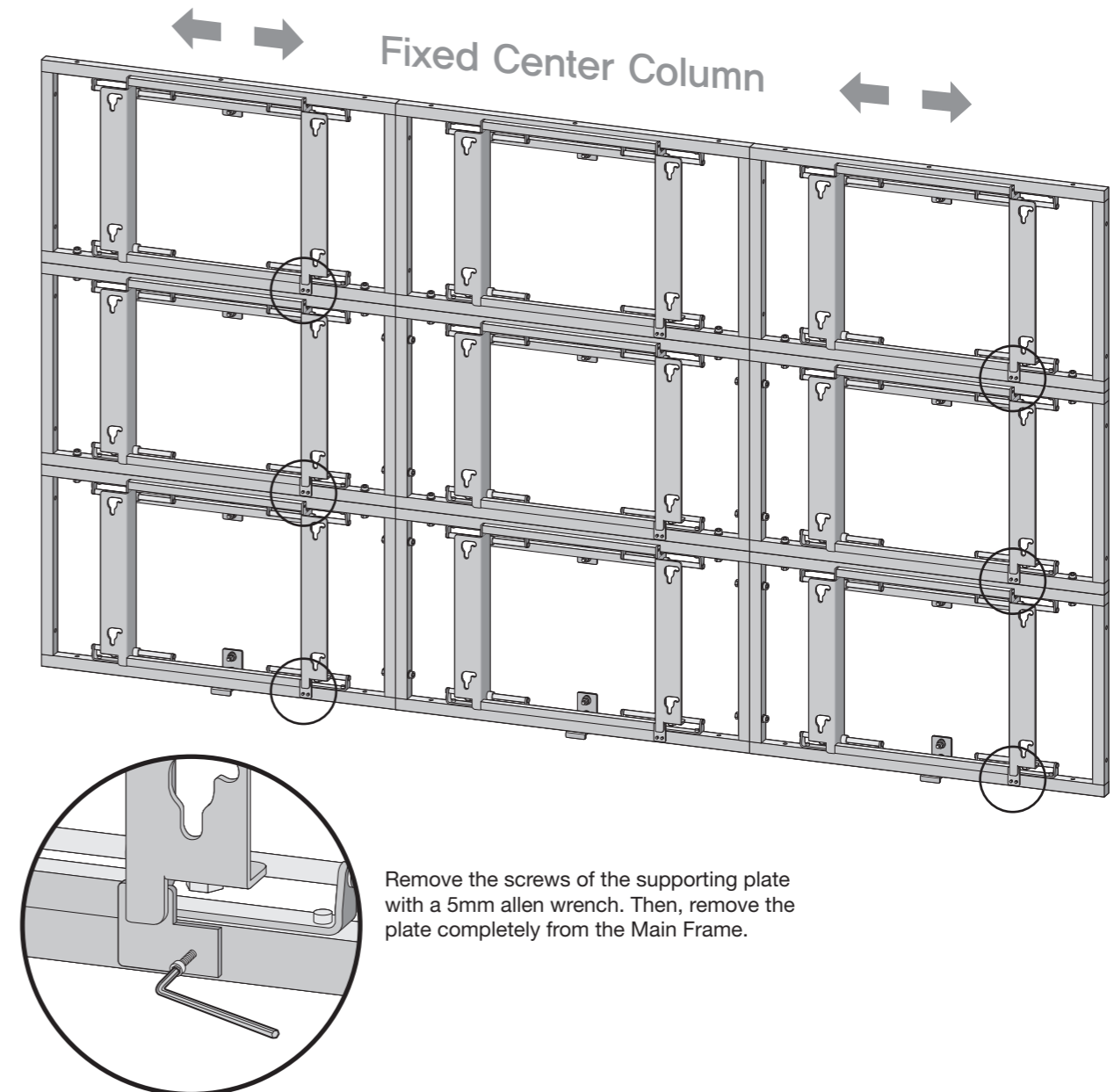

11 Fix both rows at the vertical axis as "Y-Axis Link" based on the right side.

- Fix both rows at the vertical axis as "Y-Axis Link" to the right side of the Main Frame bracket for the simultaneous movement of the vertical axis.

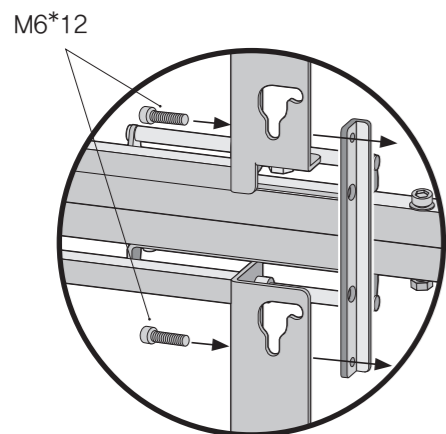
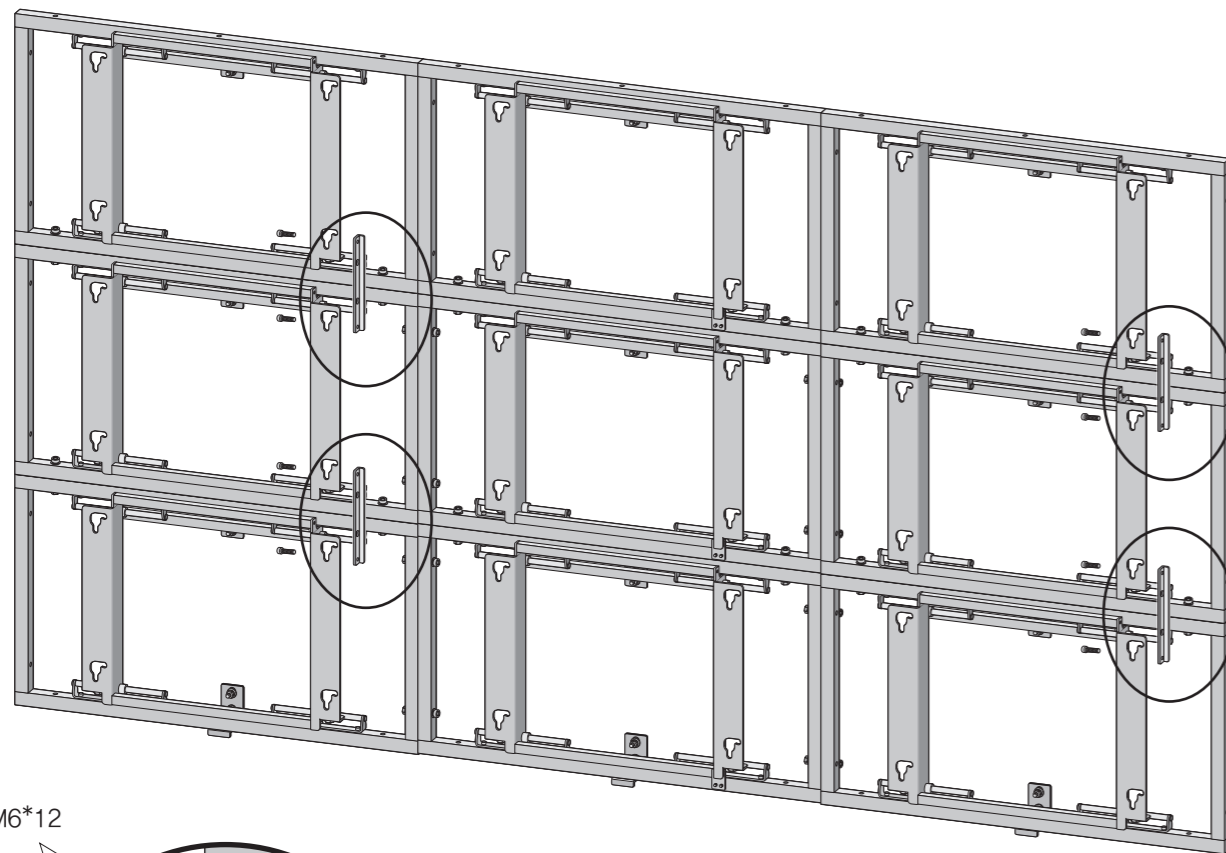

Connect the Main Frame and "Y-Axis Link" with M6*12 bolts using a 5mm allen wrench.

5. Installing the MLCD

1 Attach the PEG and Guide Pin to the MLCD.

- Assemble the four PEGs at the back of MLCD.
- Install the Guide Pins where MLCD touches.

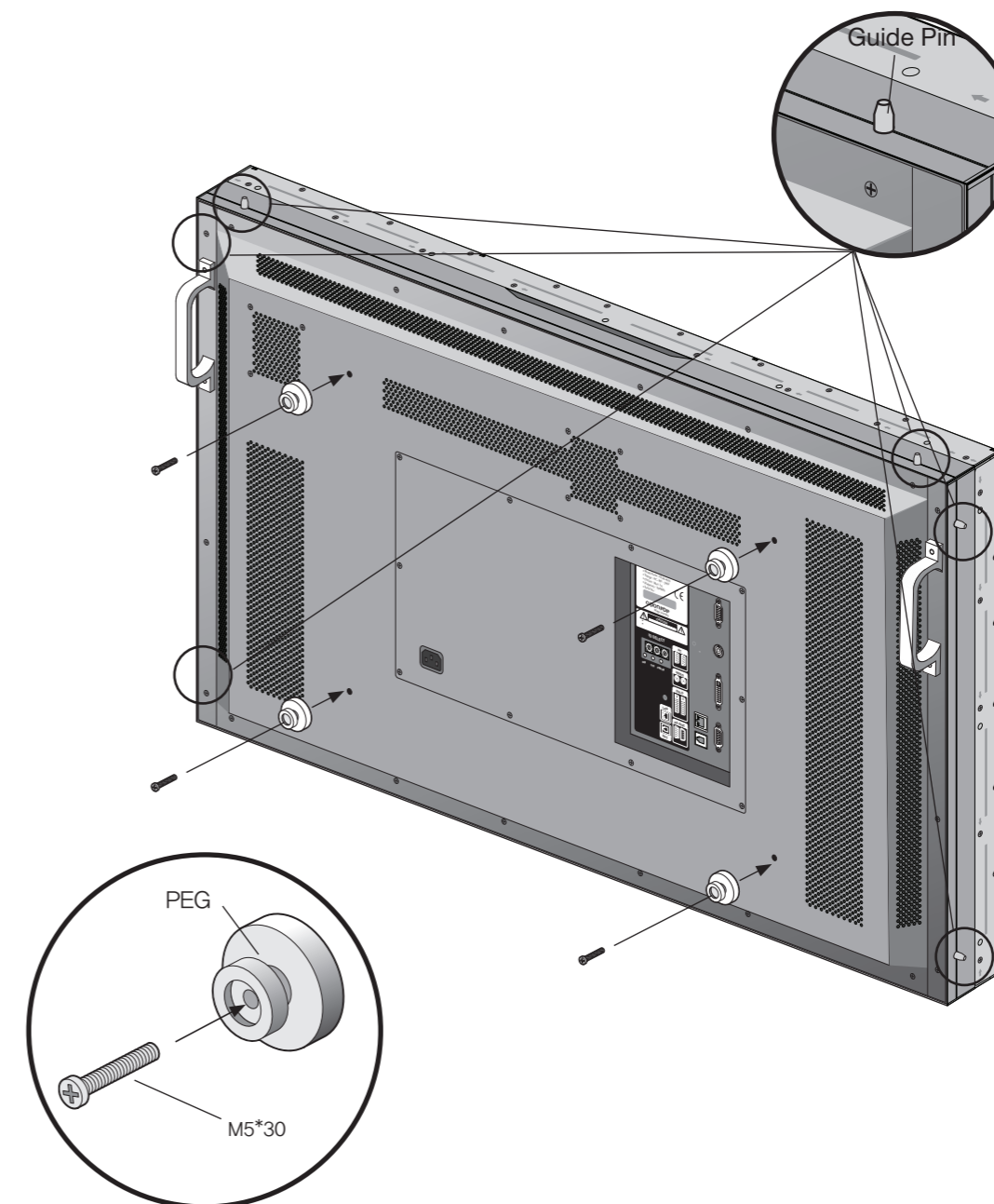

There is a hole for the installation of the Guide Pin at the upper part and the sides.

Fasten 4 PEGs in the back of MLCD with M5*30 bolts.

2 Set MLCD ID and connect all the necessary external devices and power.

- Set ID, make necessary connections and power before hang the MLCD sets on the wall.
- There is no room for such work after installation.
- Set MLCD ID as shown in the following figure.
- Make necessary connections such as VCR, PC and power, etc one by one.
- Neatly arrange all the connection cables. If they are stretched out or disorganized, it may cause personal injury or bad connection

* For more information for ID setting and connection, please refer to MLCD user manual.

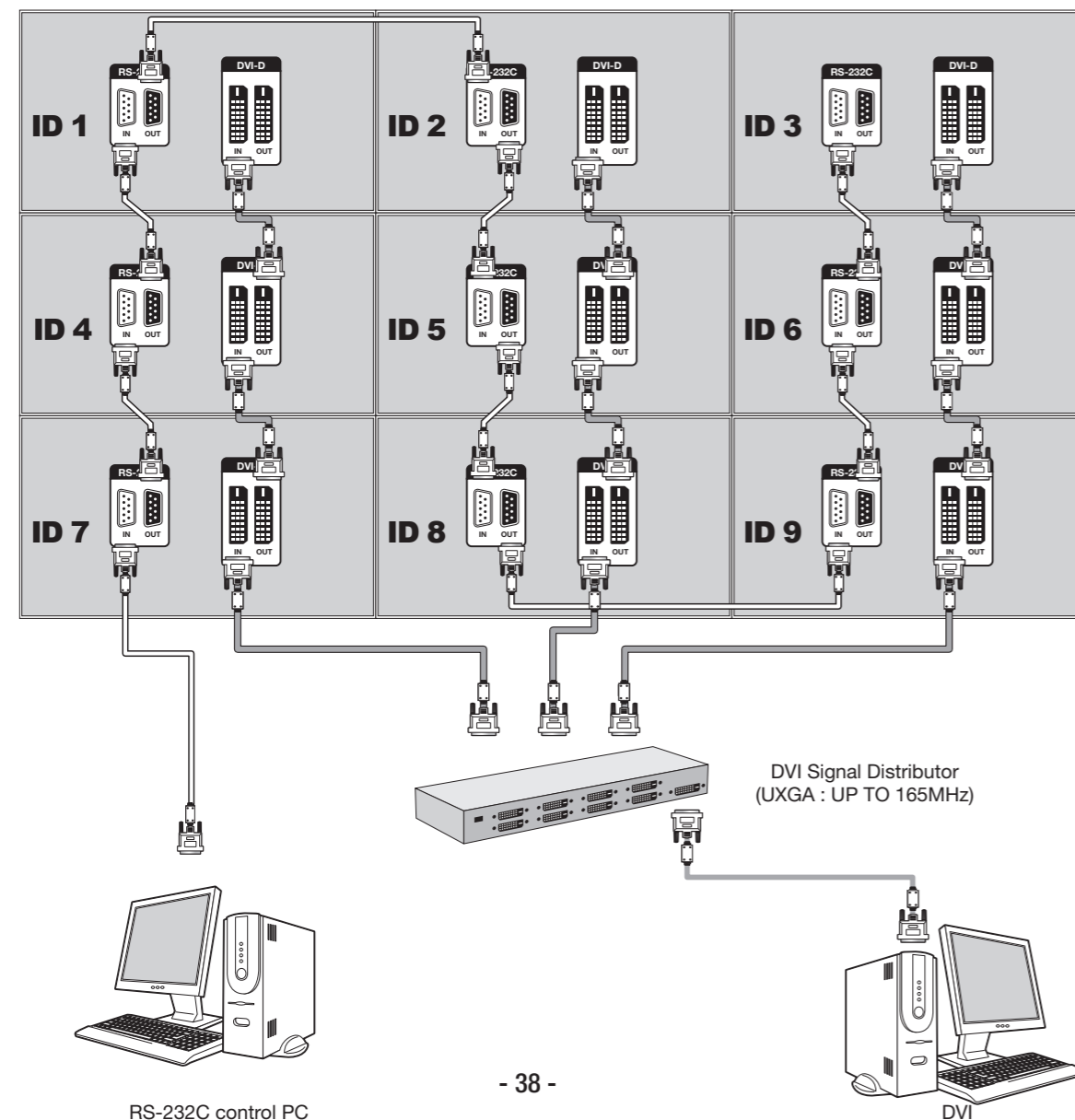

3 Install the MLCD from the lower part of the middle set.

- Insert the PEGs in the PEG holes.
- Put the set down slowly. The panels can be damaged by impact.
- Install the MLCD from the bottom of both sides after completing the installation at the lower middle part.
- It is easy to install the set after connecting the basic cables for the Wall Unit Type.

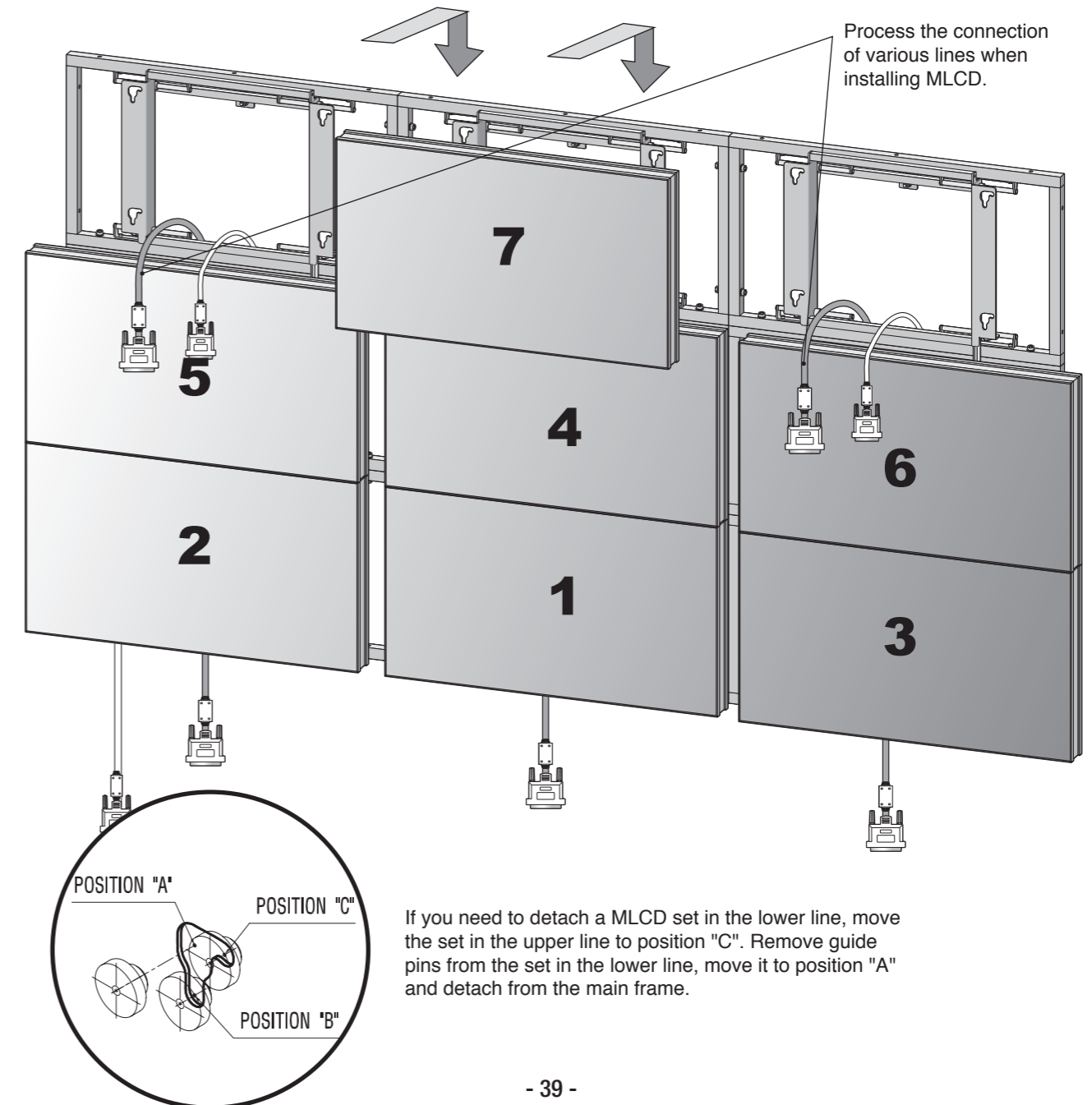

4 Fix the set by pushing towards the supporting plates at the center of the vertical axis after completing the installation of MLCD.

- Install the Fix Bracket of both sets at the vertical axis by pushing towards the supporting plates at the central area.
- Install the "FIX BRACKET UNIT" of both sets at the vertical axis by pushing towards the supporting plates at the central area.
- FIX BRACKET UNIT is manufactured basically for OLM-4610/OLM-4650. The other models need to detach EXTENSION BRACKET from FIX BRACKET UNIT to install.

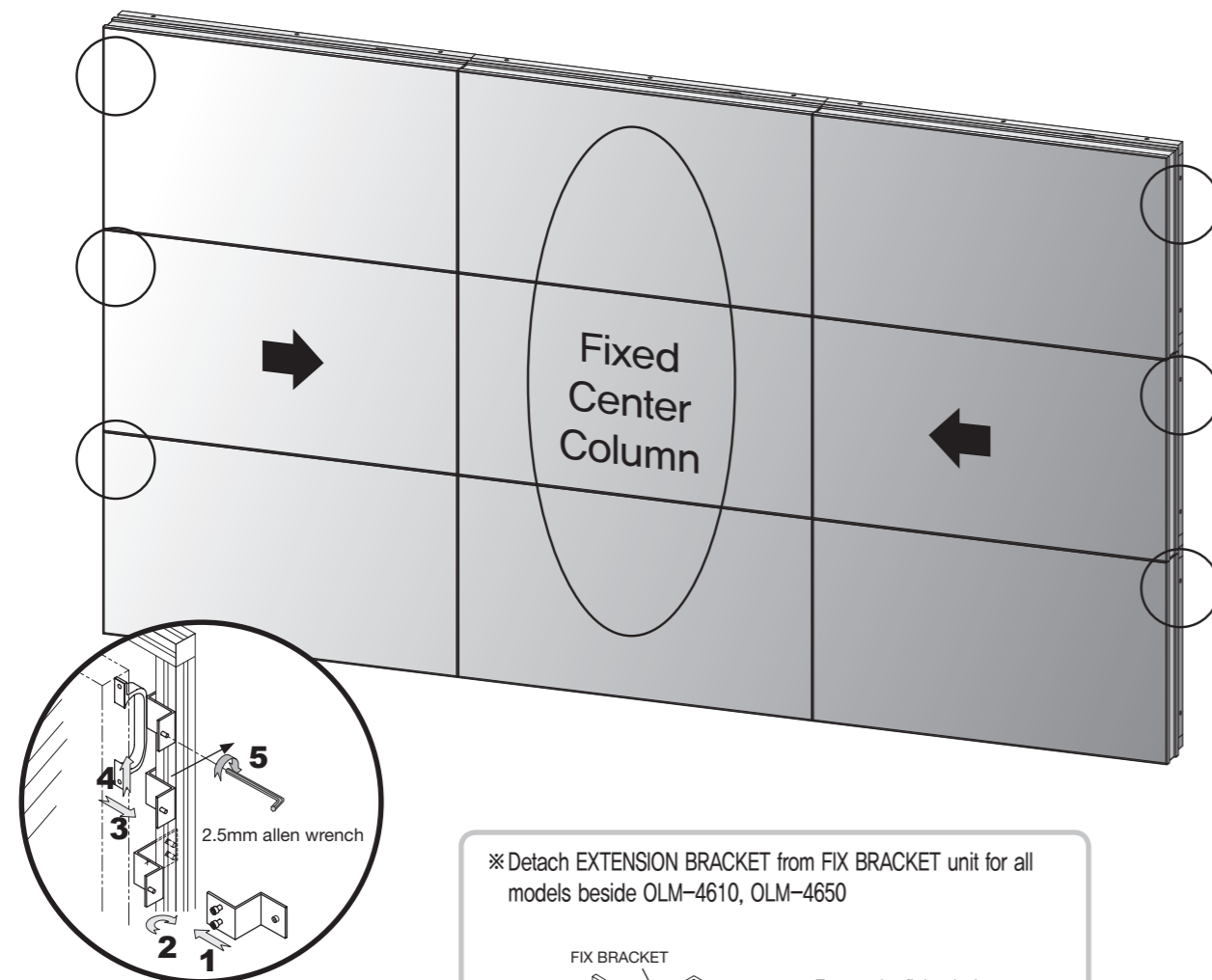

Attach the FIX BRACKET UNIT to the main frame and fix with fixing bolts next to MLCD handle. Use 2.5mm allen wrench.

※ Detach EXTENSION BRACKET from FIX BRACKET unit for all models beside OLM-4610, OLM-4650

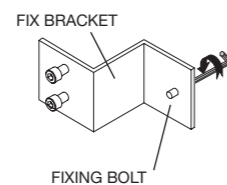

• Fasten the fixing bolt at the proper position of each MLCD model.

6. Adjust the MLCD gap with the Adjuster.

The gap of the MLCD can be fixed using the Adjuster.

- To fix the gap detected between the MLCD or when the MLCD is tilted after the installation, use the Adjuster.
- Install the Adjuster at the lowest part of the Main Frame using the 5mm allen wrench.

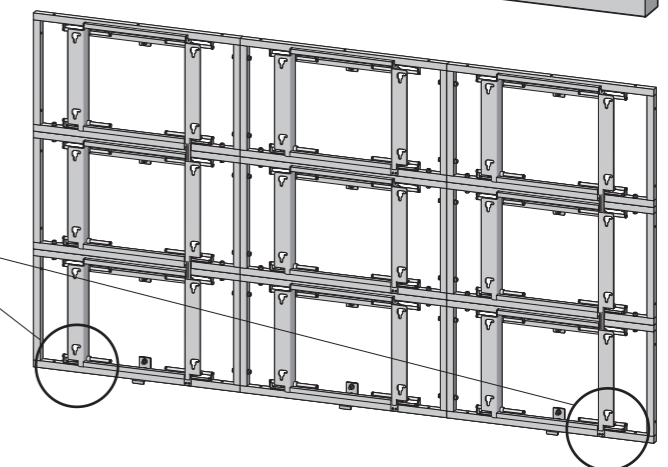
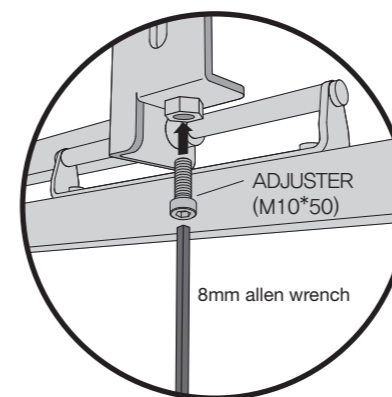
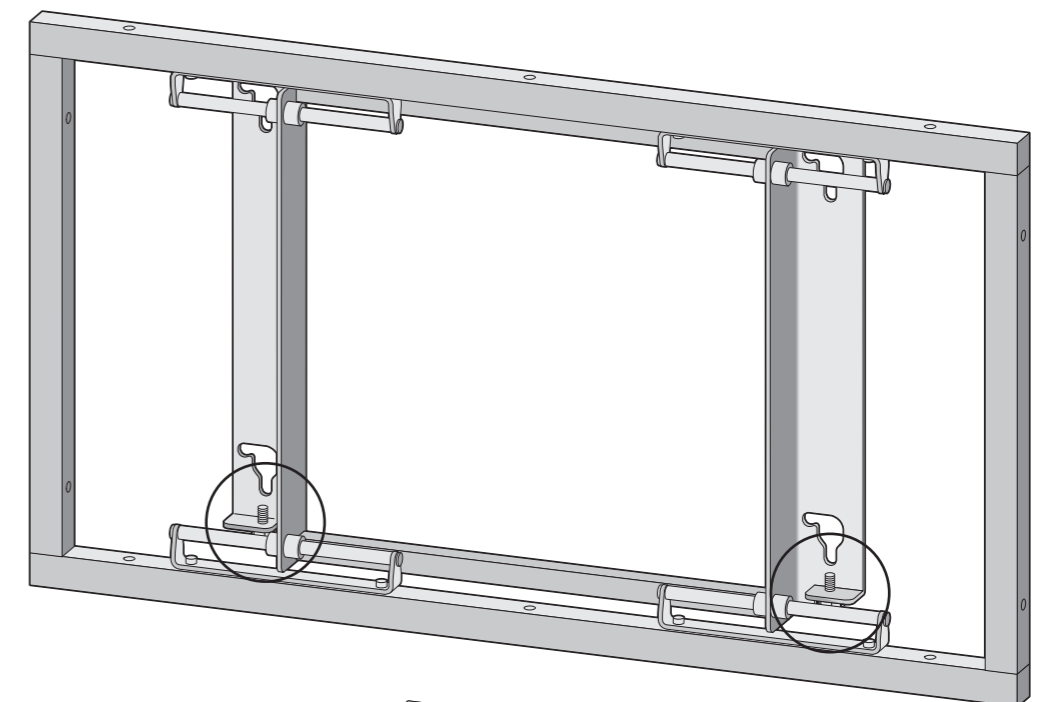

It is possible to lift or lower the Main Frame using a 8mm allen wrench after the Adjuster was installed at the lower part of the Main Frame.

SPECIFICATION

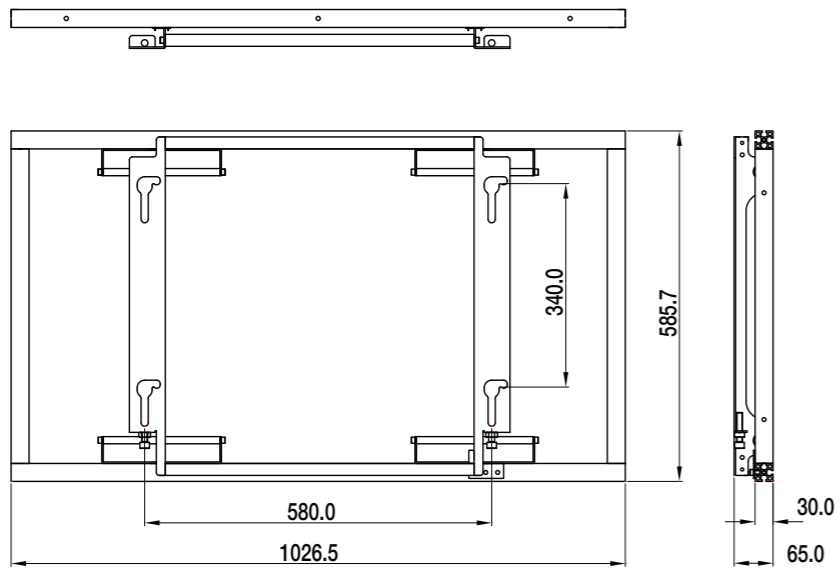
External dimension	1026.5mm(W) x 585.7mm(H) x 65mm(D)
	
Weight	7.5kg(±0.5kg)

MEMO

MEMO

MEMO