

A revolutionary MPDP

# Infinitely Expandable **MPDP**

A revolutionary MPDP  
Infinitely Expandable MPDP

**ORION CO., LTD.**  
[www.oriondisplay.net](http://www.oriondisplay.net)

Address: 257-6, Gongdan-dong, Gumi-si, Gyeongsangbuk-do, Korea  
Tel : +82-2-6678-8533, Fax: +82-2-6678-8599



## **User's Manual** **OPM-4260 | OPM-4260R**

Thank you for purchasing our MPDP.  
Please read through this user's manual for safety before installing this product.  
This product is manufactured for Multi Plasma display model only.

## Features of MPDP

- ▶ Enjoy a wide flat screen with high brightness and high quality.
- ▶ Easy to install and move due to its thin design
- ▶ Enjoy your favorite programs with various split-screen features simultaneously presenting several programs.

## Thank you for purchasing our MPDP monitor.

This manual describes how to use the product and notes in use.  
Please read the manual carefully before using it.

After reading this manual, please retain for future reference.

If you have any questions or a problem occurs, please contact either the company you purchased this product from or an authorized service center.

※ **Displaying static picture for an extended period of time may cause an burn-in effect.**  
**Brightness drop or pixel problem caused by burn-in effect are not the subject to warranty service.**



### Warning

If you fail to comply with the regulations for safety and proper use, fire or injury may be caused.



### Warning

To prevent electric shock, Do not remove cover.  
No user serviceable part inside  
Refer servicing to qualified service personal.

## Supplied Accessories

User's Manual



Multi-Screen Control System(MSCS)



Guide Pin (4pcs)



Ferrite Core (1pc)



Handle (2 pcs)

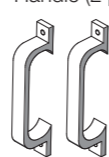

DVI-D Cable



Power Cable



RS-232C Cable



Bolt (4 pcs)

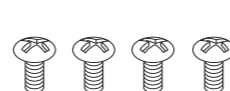

## Optional Accessories

MAIN FRAME  
(refer to page 16~17)

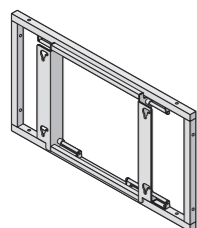

DVI Converter  
(ODC-10000)

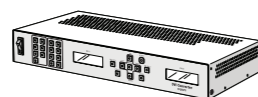

New MFC SET

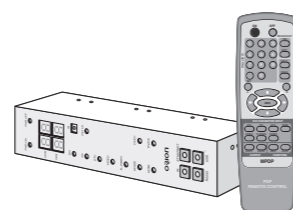

※ The ferrite core is used to shield the power cable from interference.

※ When connecting a cable, open the ferrite core and clip it around the cable near the plug.

Infinitely Expandable **MPDP**



## Notice to users

### Class A digital device

It is a device designed for business purpose with a safety certificate for electromagnetic interference, which user should be mindful of.

## " Important Safety Instructions"

- 1) Read these instructions.
- 2) Keep these instructions.
- 3) Heed all warnings.
- 4) Follow all instructions.
- 5) Do not use this apparatus near water.
- 6) Clean only with dry cloth.
- 7) Do not block any ventilation openings. Install in accordance with the manufacturer's instructions.
- 8) Do not install near any heat sources such as radiators, heat registers, stoves, or other apparatus (including amplifiers) that produce heat.
- 9) Do not defeat the safety purpose of the polarized or grounding-type plug. A polarized plug has two blades with one wider than the other. A grounding type plug has two blades and a third grounding prong. The wide blade or the third prong are provided for your safety. If the provided plug does not fit into your outlet, consult an electrician for replacement of the obsolete outlet.
- 10) Protect the power cord from being walked on or pinched particularly at plugs, convenience receptacles, and the point where they exit from the apparatus.
- 11) Only use attachments/accessories specified by the manufacturer.
- 12) Use only with the cart, stand, tripod, bracket, or table specified by the manufacturer, or sold with the apparatus. When a cart is used, use caution when moving the cart/apparatus combination to avoid injury from tip-over. 
- 13) Unplug this apparatus during lightning storms or when unused for long periods of time.
- 14) Refer all servicing to qualified service personnel. Servicing is required when the apparatus has been damaged in any way, such as power-supply cord or plug is damaged, liquid has been spilled or objects have fallen into the apparatus, the apparatus has been exposed to rain or moisture, does not operate normally, or has been dropped.  
The symbol in figure 21 shall be shown adjacent to the text of item 12 above.

	<b>CAUTION</b> RISK OF ELECTRIC SHOCK DO NOT OPEN	
<p><b>CAUTION : TO REDUCE THE RISK OF ELECTRIC SHOCK, DO NOT REMOVE COVER (OR BACK). NO USER-SERVICEABLE PARTS INSIDE. REFER SERVICING TO QUALIFIED SERVICE PERSONNEL.</b></p>		



This symbol is intended to alert the user to the presence of uninsulated "dangerous voltage" within the product's enclosure that may be of sufficient magnitude to constitute a risk of electric shock to persons.



This symbol is intended to alert the user to the presence of important operating and maintenance(servicing) instructions in the literature accompanying the appliance.

**NOTICE**

1. To disconnect the apparatus from the mains, the plug must be pulled out from the mains socket, therefore the mains plug shall be readily operable
2. WARNING - To reduce the risk of fire or electric shock, do not expose this appliance to rain or moisture.
3. Apparatus shall not be exposed to dripping or splashing and no objects filled with liquids, such as vases, shall be placed on the apparatus.
4. Use only a properly grounded plug and receptacle
5. "Warning" CAUTION – These servicing instructions are for use by qualified service personnel only. To reduce the risk of electric shock, do not perform any servicing other than that contained in the operating instructions unless you are qualified to do so.

**Contents**

※Cautions for consisting MPDP System .....	4
※Clearance for Ventilation .....	6
※Do not cover the vent hole for the fan.....	7
※Cleaning and Maintenance .....	7
※Please keep following instruction for panel protection without exception.....	8
※Handle with Caution.....	9
1. Safety Precautions .....	12
2. How to Install.....	14
3. Guidance for Users .....	18
4. How to Connect Cables .....	20
4.1. Connection of Single MPDP .....	20
4.2. Connection of Multiple MPDP.....	22
4.3. Connection of Control Cable - In case of using MSCS.....	24
4.4. Connection of Control Cable - In case of using the other control program besides MSCS .....	26
4.5. Connection of DVI cable.....	28
4.6. Connection of optional accessory .....	29
4.7. ID setting of X x Y MPDP.....	30
5. Setting and operation of MSCS software.....	31
5.1. MSCS Installation.....	31
5.2. Start MSCS.....	32
5.3. Setting of COM Port.....	33
5.4. Setting of LAN Port (In case of connecting to a LAN Hub) .....	34
5.5. Setting of LAN Port (In case of connecting directly to user's computer) .....	36
5.6. "New design/Last design" setting.....	39
5.7. Multi-screen configuration .....	40
5.8. Selecting the command transmission method .....	40
5.9. Power On/Off.....	41
5.10. Changing the input source .....	44
5.11. Slide Control .....	47
5.12. Picture Control .....	50
5.13. Timer Control .....	51
5.14. Sync Control .....	52
5.15. Tracking Control .....	53
5.16. ORION Homepage log on and Version Information.....	54
6. Control Method of optional accessory.....	55
6.1. New MFC .....	55
6.2. DVI Converter .....	58
7. MSCS Protocol.....	66
※Attachment : ASCII to HEX Conversion Table .....	84
8. Other tips .....	85
8.1. Before calling for service.....	85
8.2. About Plasma display panel .....	86
9. Applicable DVI signals.....	87
10. Specification.....	88
11. Option Specification .....	90
11.1. DVI Converter.....	90
11.2. New MFC.....	91

## ※ Cautions for consisting MPDP System

### The number of Daisy chain connection

- The image quality may vary depend on the quality of signal and cable condition.

INPUT SOURCE	Resolution	Connection	Remark
DVI	1600 x 1200 x 60Hz	6 sets	HDCP Available
PC	1600 x 1200 x 60Hz	3 sets	
VIDEO	NTSC, PAL, SECAM	6 sets	
RS-232C		30 sets	ORION Cable Only

- If you need to use more MPDP sets than indicated in the table, using a DVI distributor is highly recommended.

### Caution for the other control program besides MPDP Control Program (MSCS)

- If you want to use automatic power on/off function that make MPDP turned on/off by connecting main power, allow at least 20 seconds of Stand-by time before MPDP is turned on, when you make control program.
- If RS-232C communication signal or other image signal is applied to 9 or more sets simultaneously, communicational error may occur. (Power on & Broadcast)

### Environmental condition for installation

- Since MPDP panel is very sensitive for physical impact, installation requires considerable caution.
- Minimum clearance(20cm) must be secured for smooth ventilation. (See P16~17) Installation must avoid air tight or near air tight places. Improper ventilation causes malfunction and shortens product lifetime by rapid internal temperature rise. If MPDP has to be installed at the improper ventilation, additional ventilation openings or fans must be provided to keep the internal temperature between 0 ~ 35°C.
- For ground of MPDP and application devices, it should be connected as frame ground.
- Considering MPDP Max power consumption, check the main electric specification.

※ Please be noted that the film filter on the front surface of the panel may lose its color or change the color rapidly, if it is exposed to sunlight or ultraviolet rays.

※ If the internal temperature reaches to 90°C, "High Temperature" signal will be displayed at the lower left corner on the screen for 1 minute and the MPDP set will be turned off automatically.

### Consideration for easier service

- When you design the exterior design for MPDP system, consider easier disassembly for possible service occasion in the future.
- The sliding Universal Unit of ORION is recommended for easier service.
- If service people can step into the backside of MPDP system, it can greatly reduce time and effort for service.
- In case of higher locations, consider the installation location and exterior design for easier service.

### ※ Clearance for Ventilation



- When you install MPDP, make sure there is at least 20cm clearance for effective ventilation and do not seal off MPDP sets.  
If MPDP sets are installed at the locations of bad ventilation, the inner temperature can be raised rapidly and it can cause frequent malfunctions and rapid reduction of the product life.

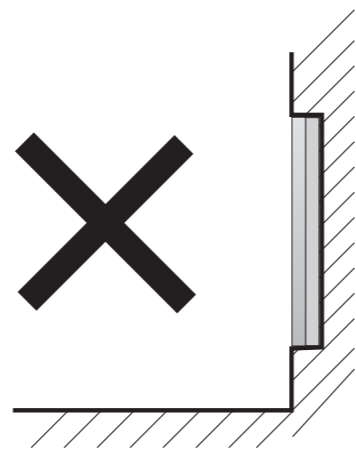
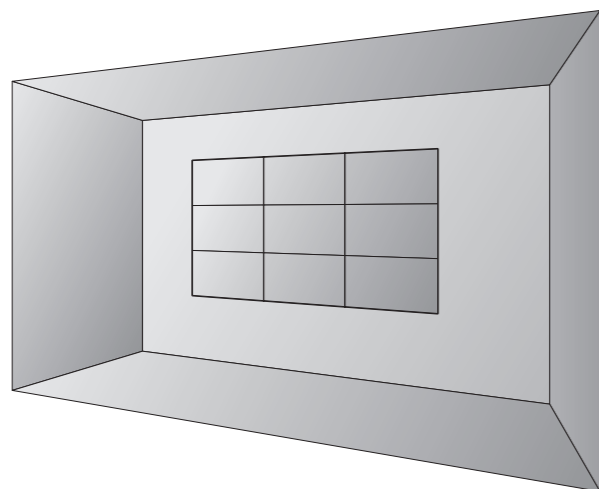
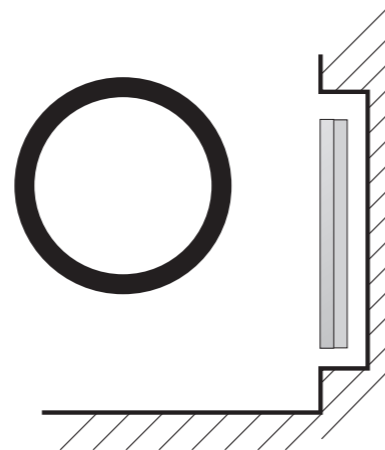
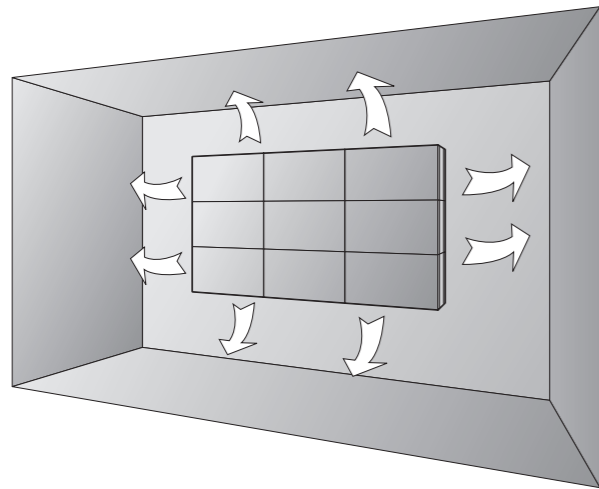

※ Ventilation space in front of MPDP must be furnished for heat dispersion. If the front space of MPDP has to be sealed, there must be consideration for the heat dispersion in the rear side of MPDP.

### ※ Do not cover the vent hole for the fan



-Carefully install MPDP not to cover the fan air holes with any structural object.  
If the holes are covered with anything, the inner temperature can be raised rapidly and it can cause malfunctions.

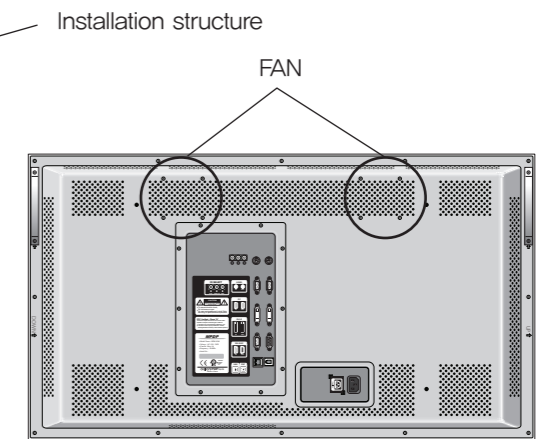
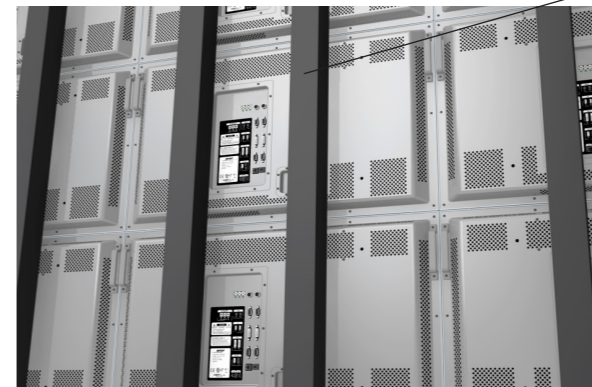

### ※ Cleaning and Maintenance



-Regularly clean off the vent holes in the back of MPDP sets.  
If the vent holes and the fan air holes are clogged with dust, it prevents the air flow inside of MPDP sets.  
It can cause rapid increase of the inner temperature and may cause malfunctions.  
Clean off the vent holes and the fan air holes with a vacuum cleaner regularly.

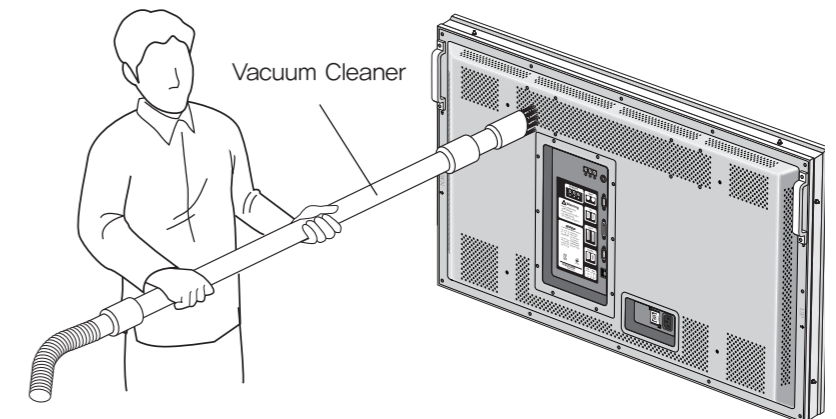

WARNING

WARNING

WARNING



※ Please keep following instruction for panel protection without exception.

- This product can be damaged even with minor impact for its nature. Please keep following instruction to carry or store the products.



※ Handle with Caution.

- Shock/Impact on the set's sides will result in internal circuit damages.
- The edge/bottom of the panel are fragile. Use shock-absorbing pads or rugs for laying down the product.

WARNING

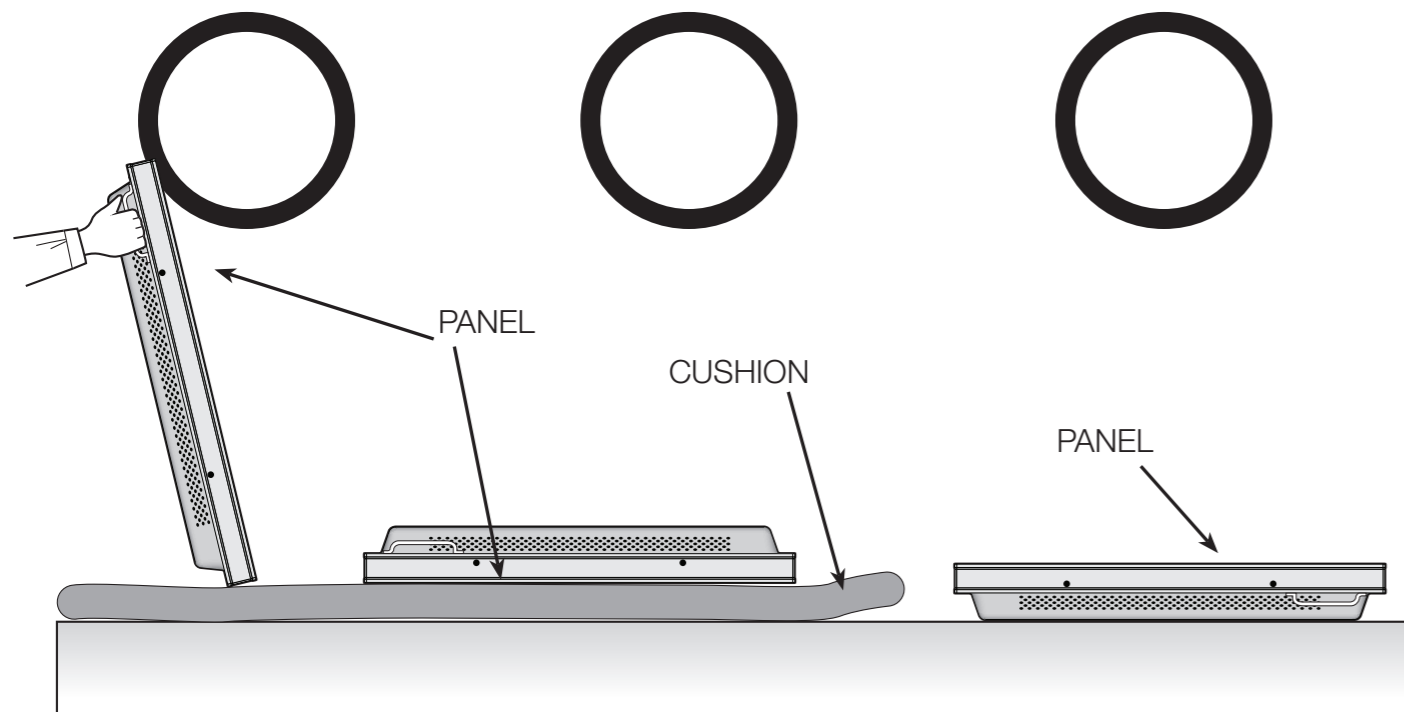

- If you need to stand PDP, you must use handles on the back and lean over the PDP to avoid panel touches ground or floor.
- If you need to lay down PDP as face down position, please use shock-absorbing pads under the PDP.
- If you need to lay down PDP as face up position, please be cautious for falling objects on the surface of the PDP.

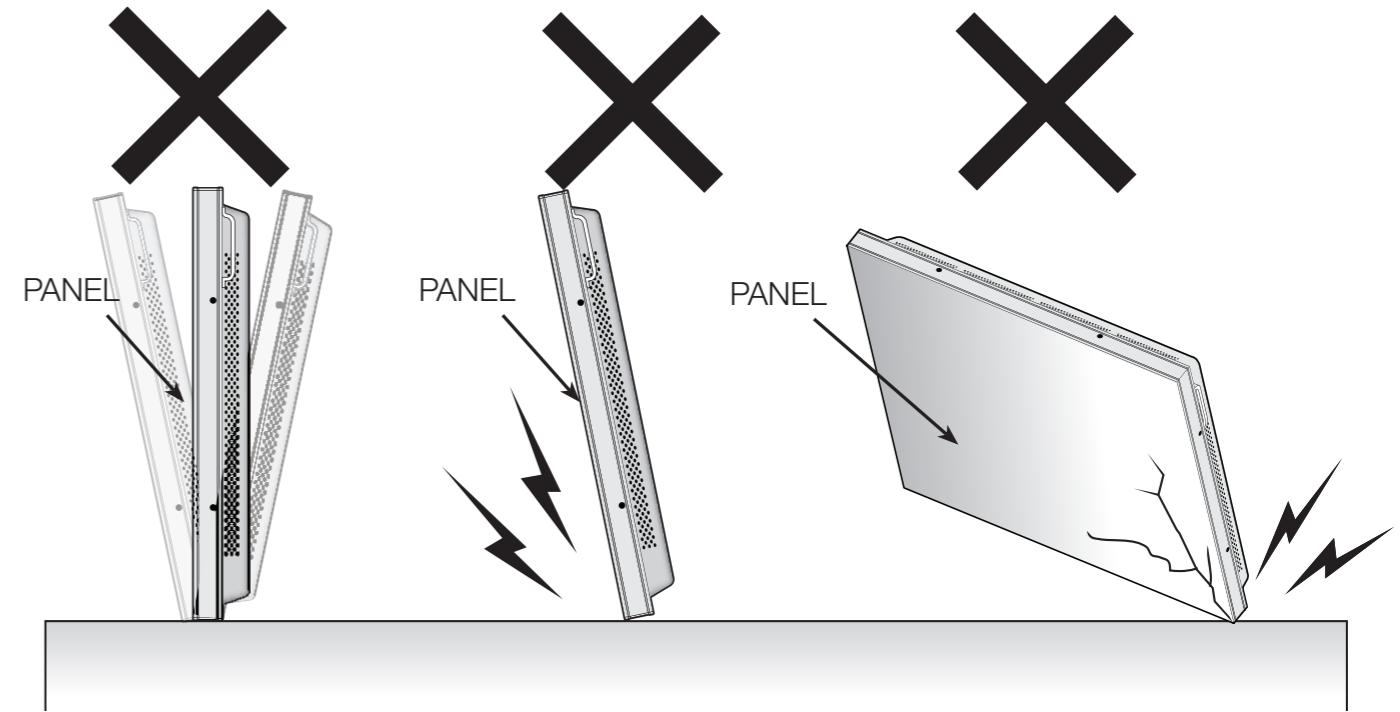

- Please do not stand PDP alone. It may fall or slip off and Panel can be broken or damaged.
- Please do not lean over the PDP. It may damage the bottom part of the PDP.
- Please do not lean over the PDP toward the edge part. It may damage the edge part of the PDP.

## Open Structure

Unlike consumer PDP product, the panel of MPDP is exposed without any protective chassis. It needs extra caution to carry or install to prevent any impact.

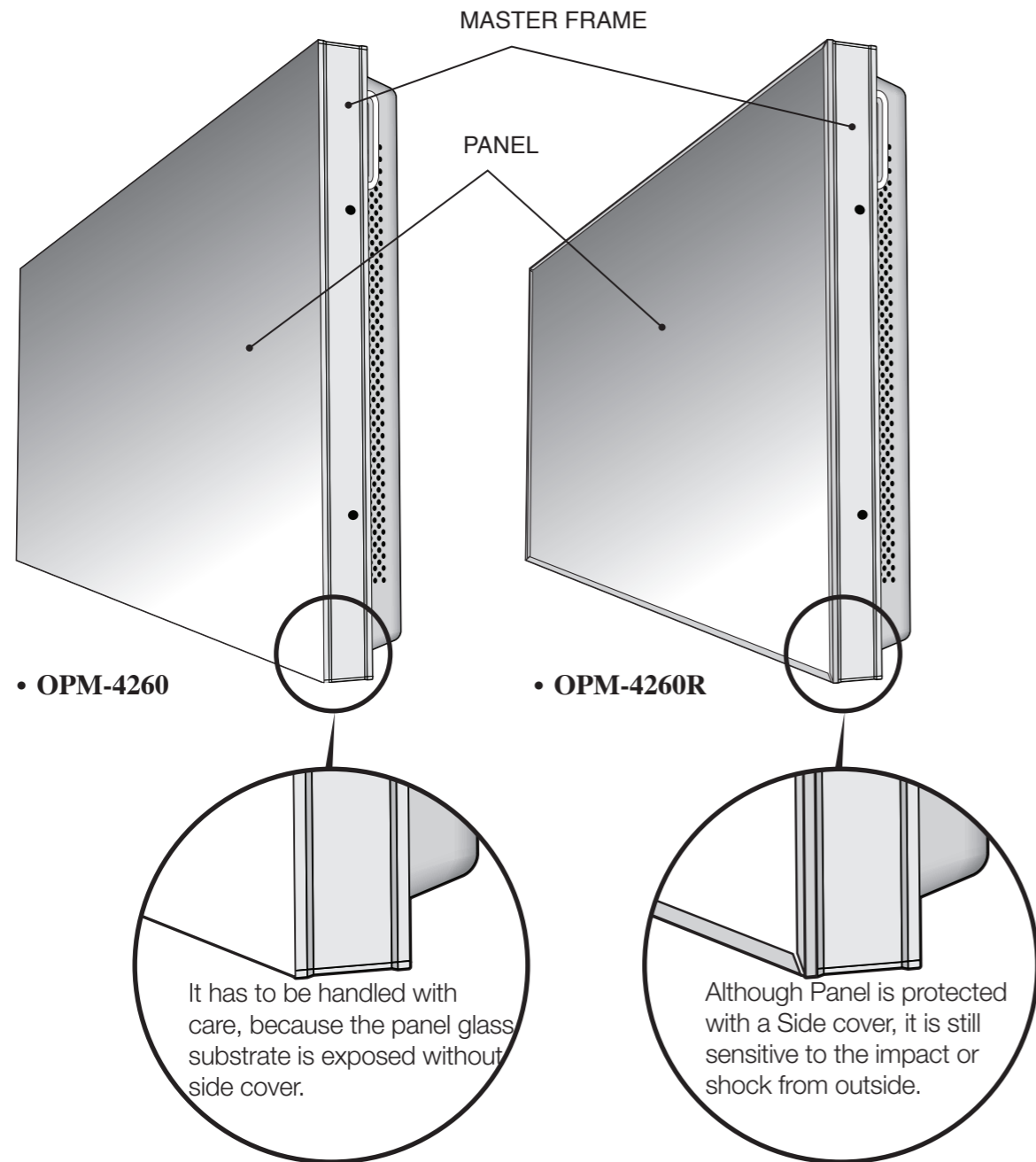

## How to carry MPDP

Please see page 14 for unpack and handle assembly. It always needs two persons to carry or install MPDP. When you carry MPDP with up straight manner, please hold handles on the back and bottom part of the panel together. Please be careful not to touch the bottom part of the panel when you put down the panel.

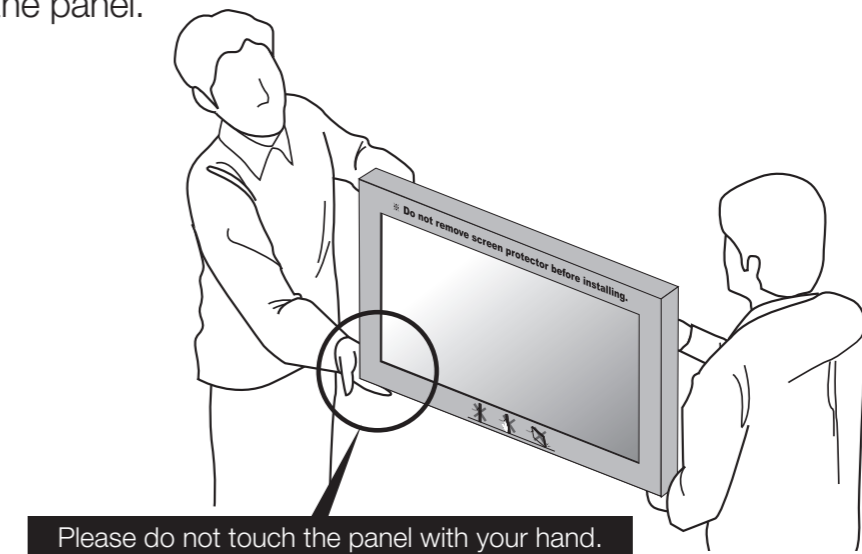

When you carry MPDP with flatbed manner, please hold handles on the back and lower part of the back. Please be careful not to touch the bottom part of the panel when you put down the panel.

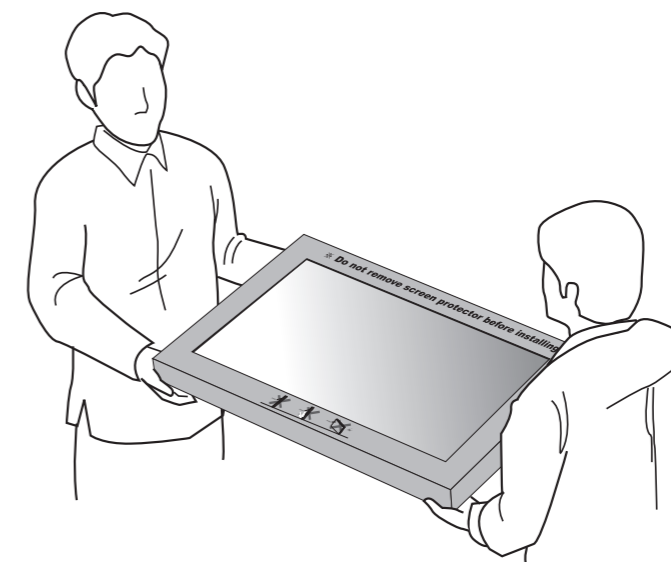

# 1. Safety Precautions

- If it operates abnormally, stop using it immediately.

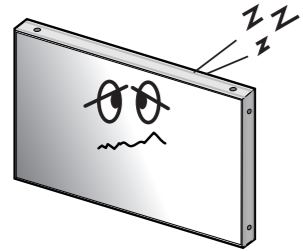

- Do not place any liquid-containing container on it. If the inside is wet, it may cause electric shock or fire.

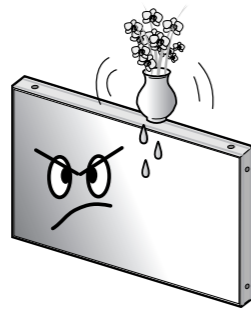

- Do not put any foreign material into the product. It may cause a failure or shorten the life span.

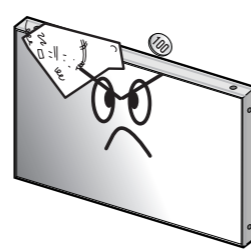

- Please refer to a specialized construction company for installing stand or wall mount unit. Otherwise, damage or injury may be caused.



- Do not touch the device when lightning strikes.

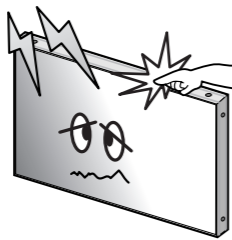

- Do not install in an unstable location. It may cause injury.

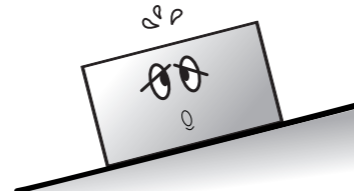

- Avoid any action to damage the power cord or power plug. It may cause fire or electric shock.

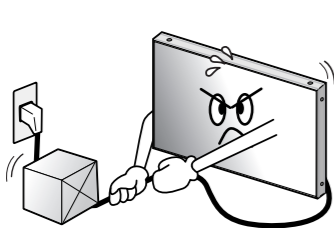

- Do not pull out the power plug with a wet hand. It may cause electric shock.



- Do not exceed ratings of AC outlet or extension cords. It may cause failure.

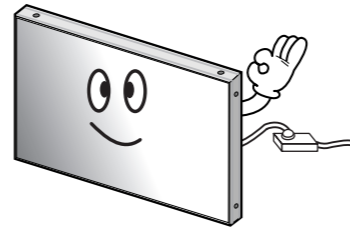

- Do not alter (or disassemble) the product. It may cause electric shock since high voltage is flowing inside.

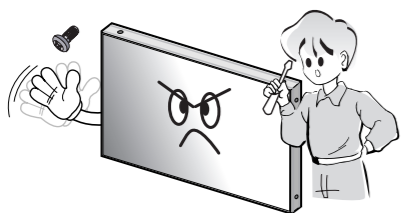

- Do not install the product where it may be exposed to direct sunlight or near any heating device. It may shorten the product's life span or cause failure.

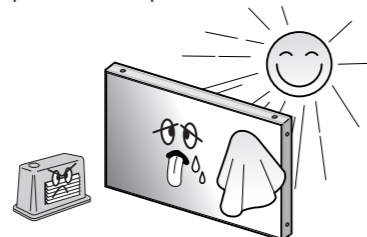

- Make sure the product is not covered with any object. If the ventilation hole is blocked, the inside temperature may rise to cause overheating resulting in fire.



- Do not pull out or hang down the connection cable. It may damage the cord to cause fire or electric shock.

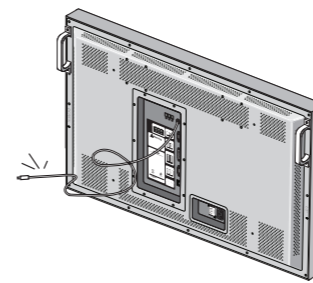

- Do not lean against the product or keep it leaned. It may cause injury or failure.

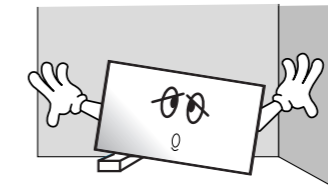

- Do not put it at any place with much humidity, dust, oil, smoke or steam. It may cause failure.

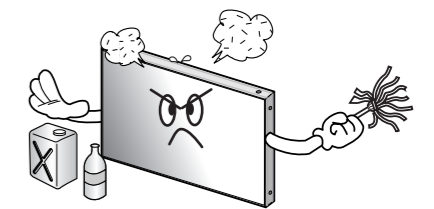

- Pull out the power plug by holding the plug. Otherwise, it may damage the power cord to cause fire or electric shock.

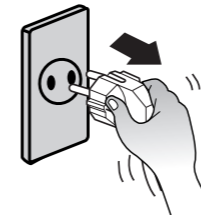

- If you do not want to use the product for a long time, keep the power plug unplugged to save electricity.
- The socket-outlet should be installed near the equipment and be easily accessible.

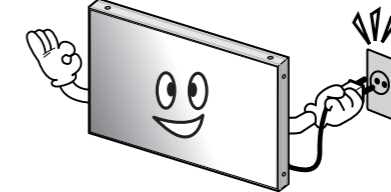

- Do not put any heavy object on it. It may cause failure.

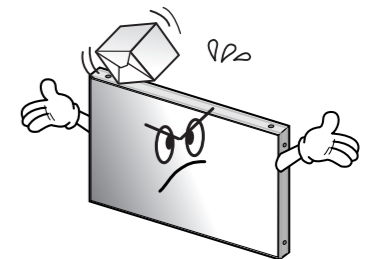

- Install the product on safe and flat surface.

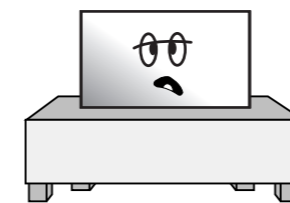

- Do not ride or step on the product. It may cause breakage when fallen down.

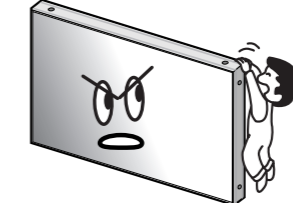

- When moving it, disconnect the connecting cable. Otherwise, it may damage the cable to cause fire or electric shock.

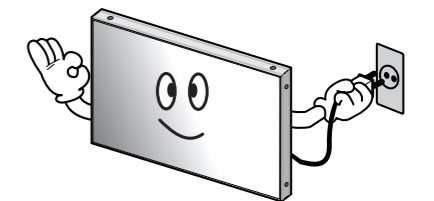

- Do not put candles on the product. If the liquid flows inside the product. It may cause electric shock or fire.

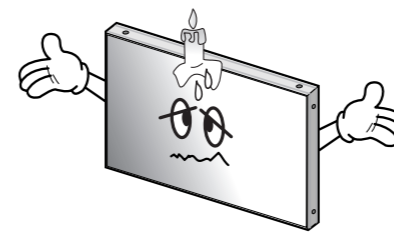

- Do not touch product's front surface with hand. Otherwise, the image quality can be lowered.

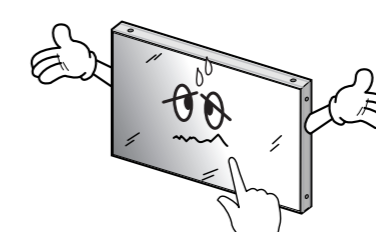

- Do not poke the front screen with sharp material. It may damage the screen and may cause malfunction of the product.

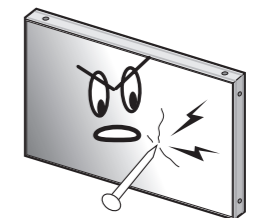



## 2. How to Install

- Install this set only at a location where adequate ventilation is available.

### How to assemble handles

1. Product is packed in a box as shown in Figure 1.
2. Please carefully remove the Packing Bag with a knife or a pair of scissors.  
 ※ Please check front and rear side before you cut the bag to prevent any damages on panel or set.

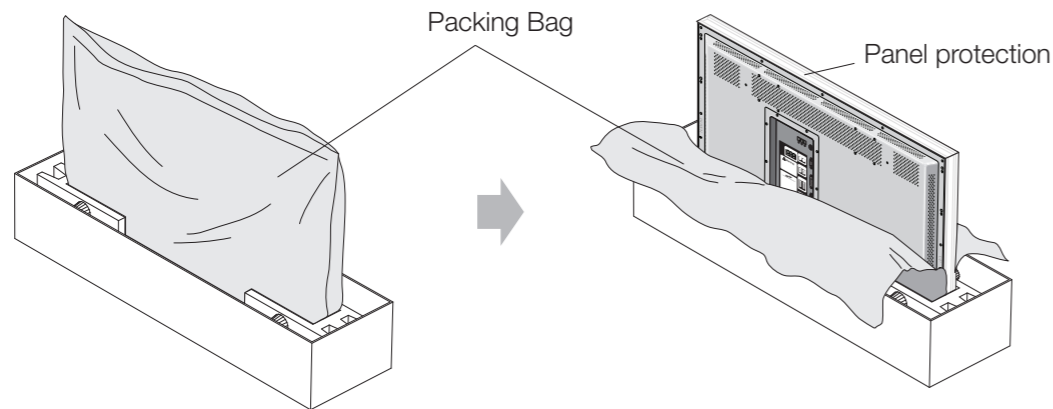

[Figure 1]

[Figure 2]

3. Please assemble handles with the bolts that are in the accessory box to the rear side as shown in the figure.

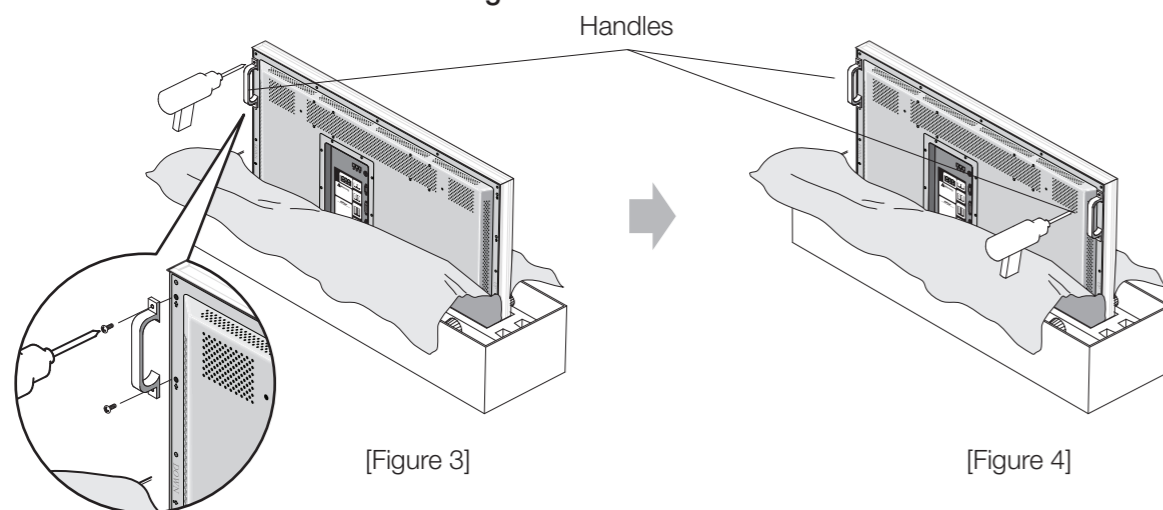

[Figure 3]

[Figure 4]

### How to move MPDP

1. 2 people hold each handle on product's back side.

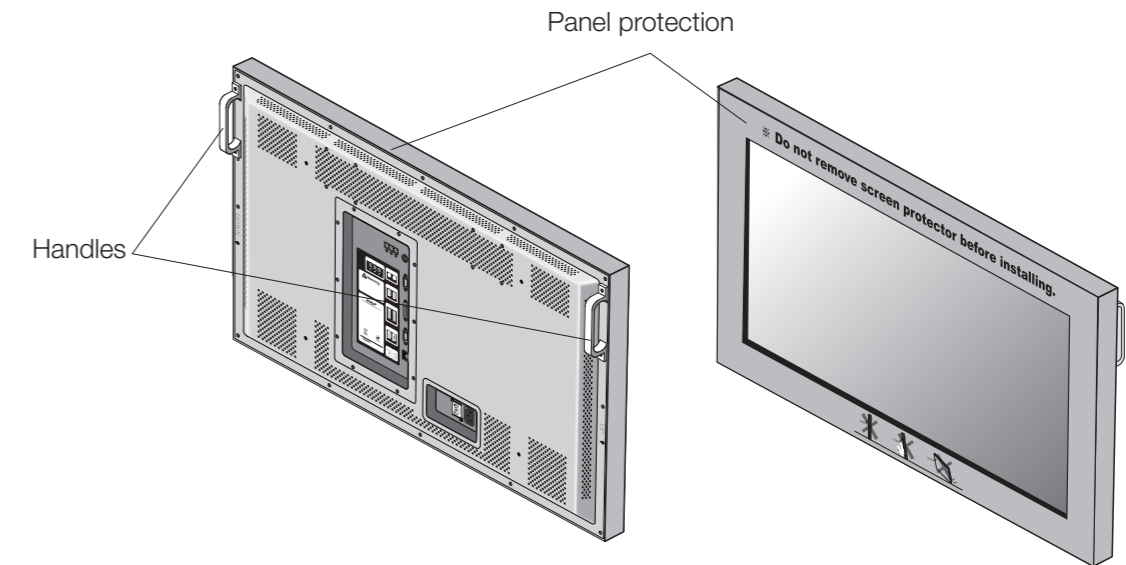

2. It needs two people to carry or install this product.

Please hold the handles in the back and the front bottom part at the same time.

- Please do not grab the panel, but grab bottom of master frame when you carry or install the products.
- Please use gloves when you carry or install the products.

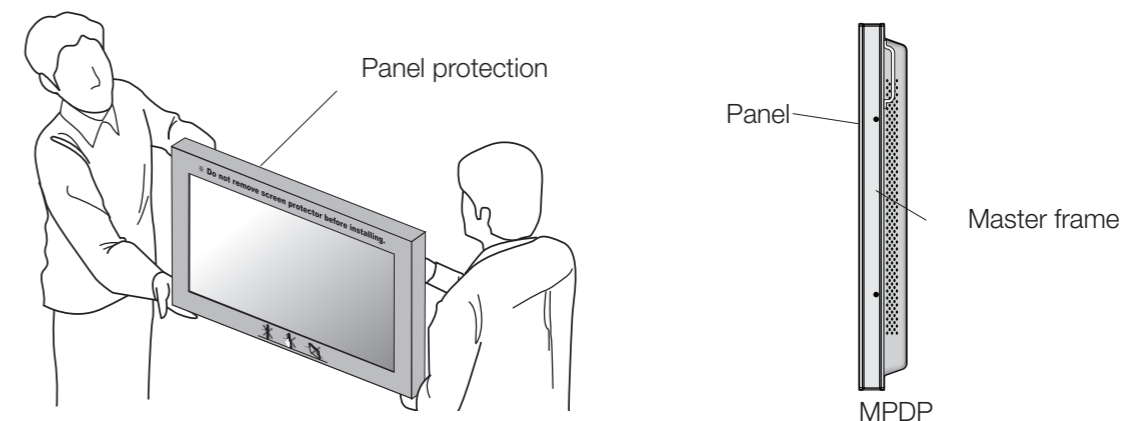

#### ※ Attention :

- Do not remove the panel protection pad until a set is completely installed on a stand or a wall hanger.
- Please carefully remove Panel protection pad to prevent any damages on the product .
- Please make sure to use panel protection when you move, carry or rent MPDP.

**MAIN FRAME Stand Unit (Option)**

- Please do not install our product at following locations to protect the product and prevent possible malfunction.
  - Places of vibration or shock: PDP set may fall and damaged
  - Next or near to Sprinkler sensors: The sensors may detect heat from a set and sprinkler can be activated.
  - Around high voltage power lines: Noise from the power line may affect screen images
  - Around heating apparatus: PDP set may be overheated and damaged.

- The set can be installed as shown below.  
(For further information, refer to the optional 'MAIN FRAME Installation and Setup Guide'.)

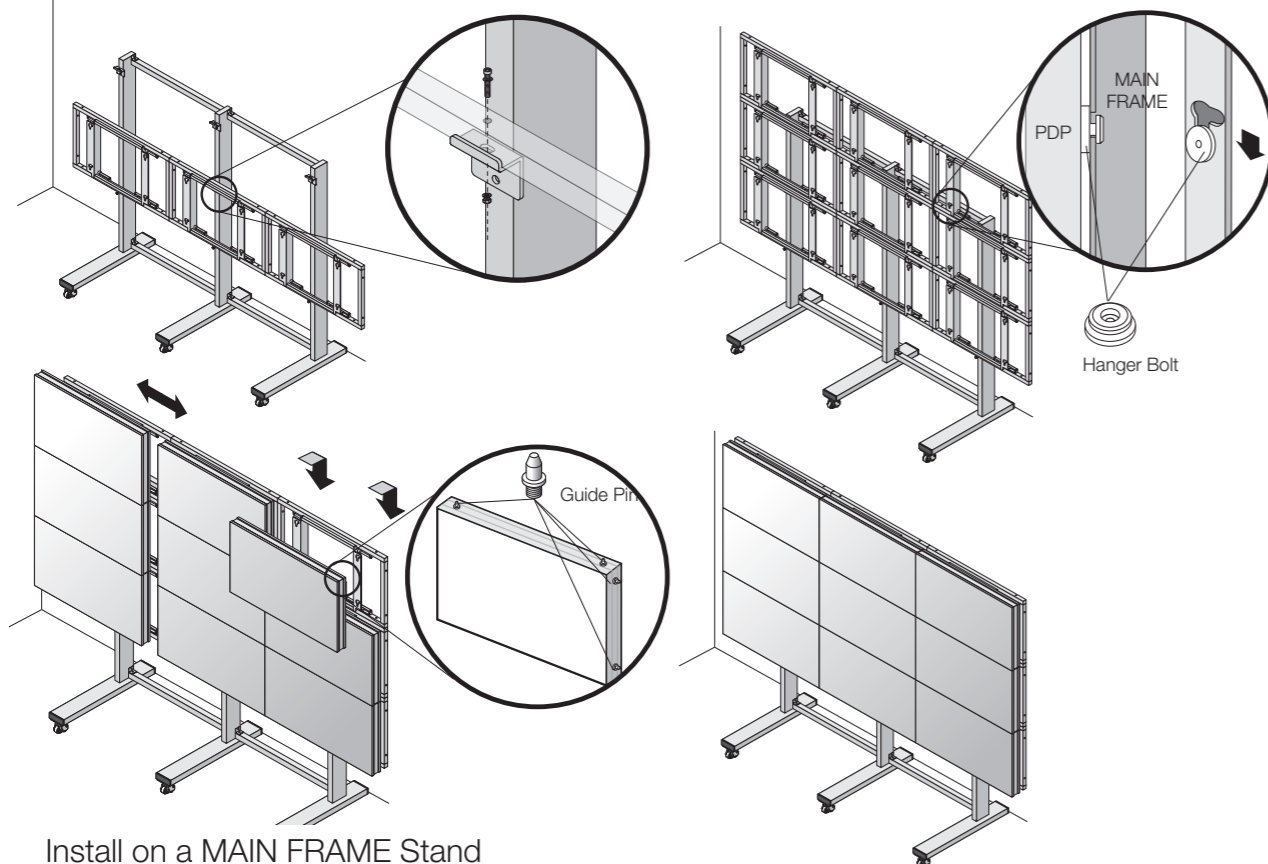

Install on a MAIN FRAME Stand  
Please secure minimum clearance as shown in the picture for adequate ventilation and technical service.

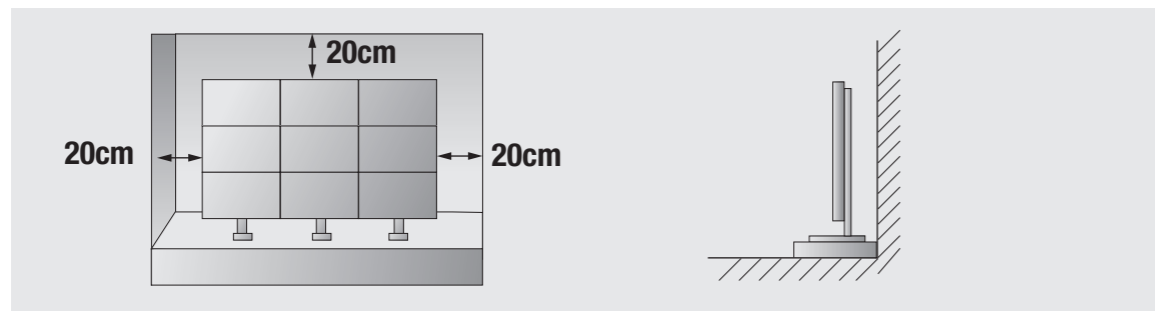

**MAIN FRAME Wall Mounting Unit (Option)**

- Please check the stability of wall.  
If the wall is not strong enough, reinforce the wall before installation.
- Please connect all the cables to proper ports in a set before installation.

- The set can be installed on the wall as shown below.  
(For further information, refer to the optional 'MAIN FRAME Installation and Setup Guide'.)

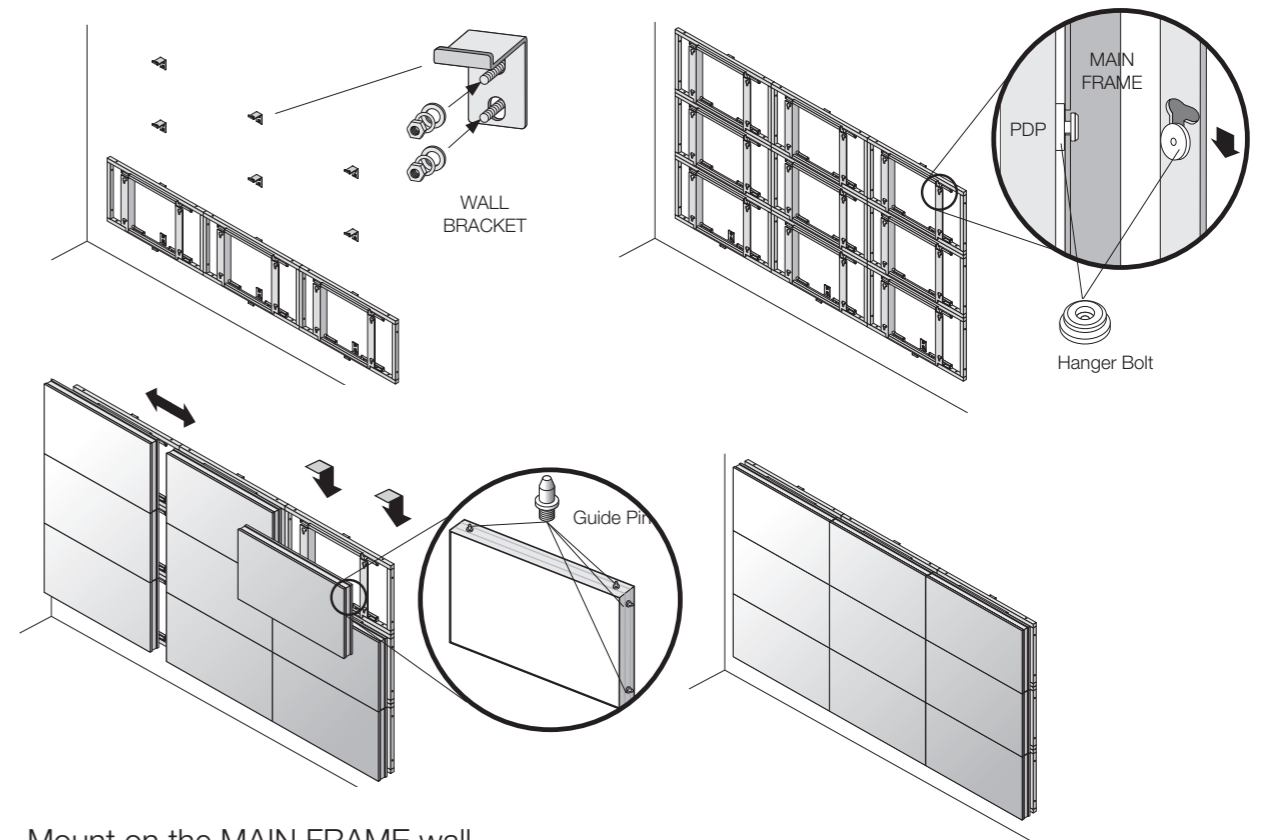

Mount on the MAIN FRAME wall  
Please secure minimum clearance as shown in the picture for adequate ventilation and technical service.

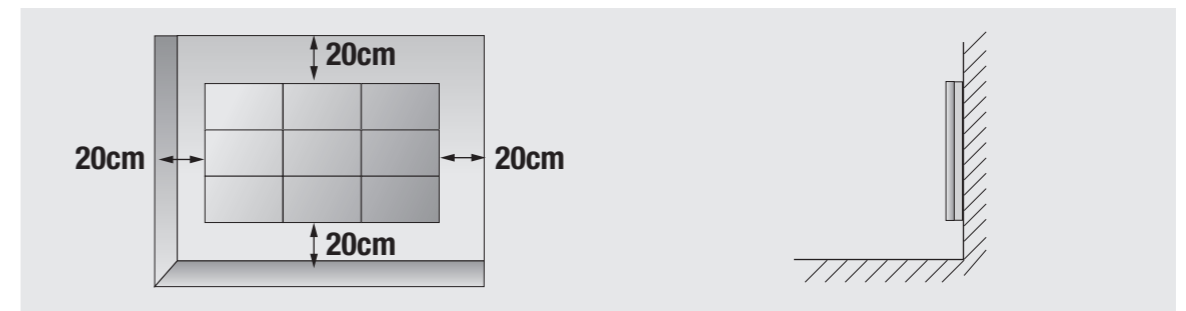

### 3. Guidance for Users

#### ■ Input/Output Terminals

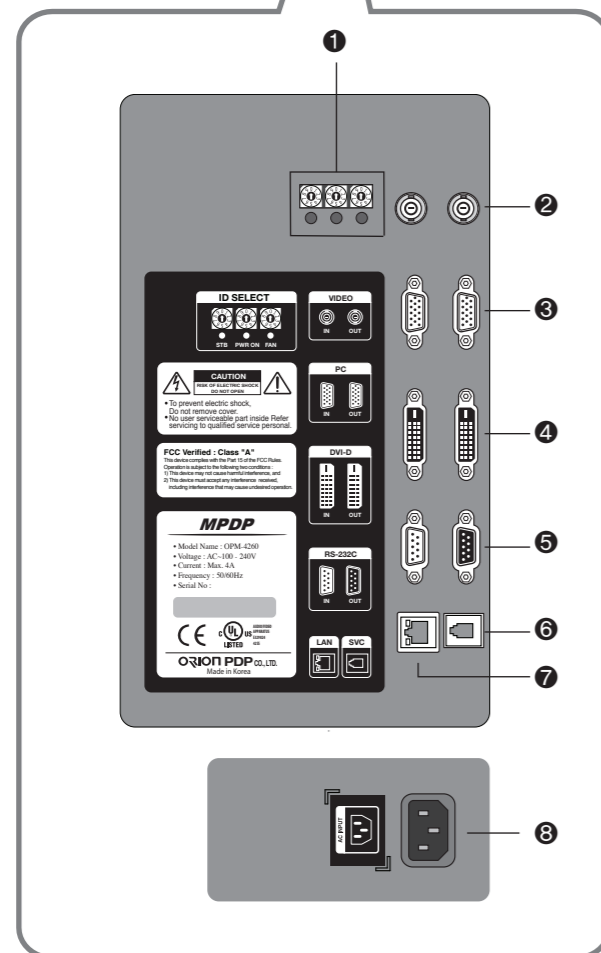
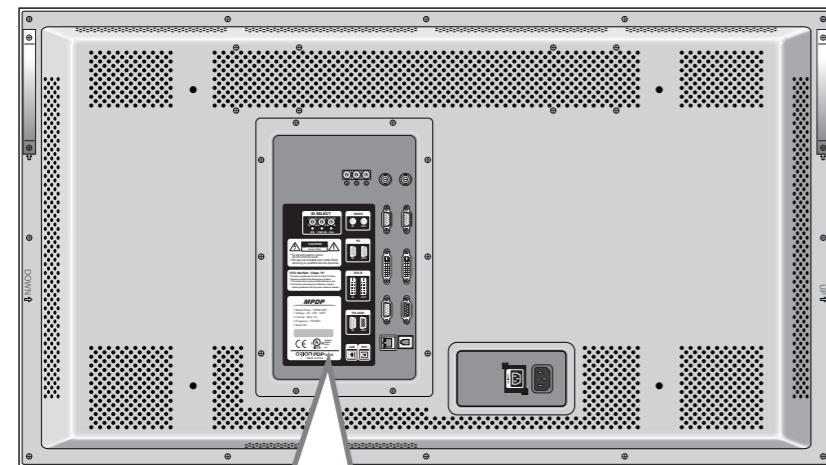

1. **ID SELECT**  
Set ID Switch
2. **VIDEO Input / Output**  
Composite Signal, BNC
3. **PC Input/Output**  
Analog RGB Signal, D-Sub 15pin
4. **DVI-D Input/Output**  
Digital RGB Signal(TMDS), single link 24pin
5. **RS-232C Input/Output**  
MPDP Control, Upgrade by Com Port, D-sub 9pin
6. **SVC**  
For the exclusive use of service, RJ11
7. **LAN**  
MPDP Control by Ethernet, RJ45
8. **AC Input**  
AC 100V ~ 240V, 50/60Hz

#### ■ Set ID Switch Setting

- Example of ID Switch setting
- You can set ID with 3 rotary switches as shown in the following figure.

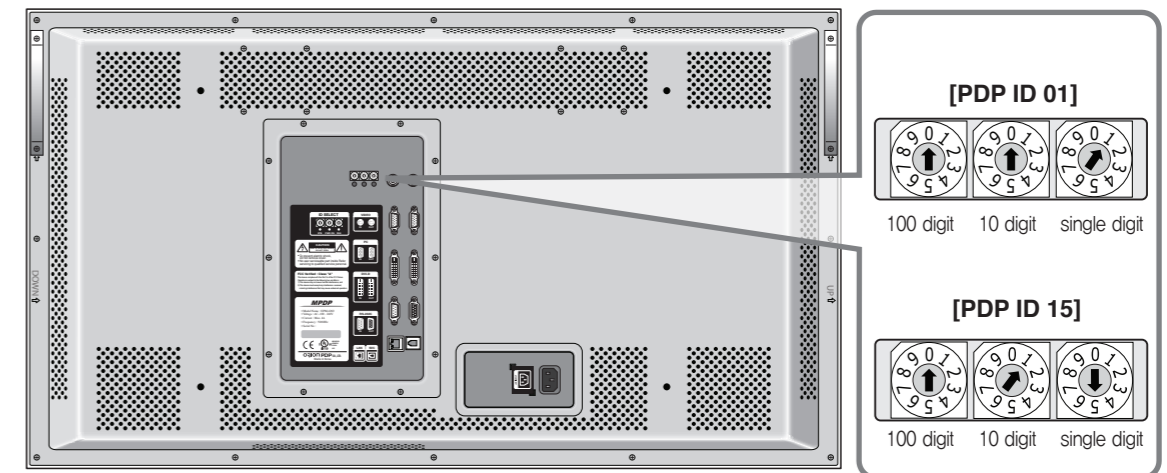

- ※ When you set ID of MPDP set, power cable must be disconnected. If power cable is not disconnected during ID setting, MPDP set may be operated with the previous ID and it may cause abnormal behavior.
- ※ For stable operation, wait for at least 10 seconds prior to use MPDP control program after the first AC power connection.

#### • LED Indication

ON ○ OFF ● BLINKING ●

LED Indication	Description
	No Power.
	Insert power cord(Stand-By state)
	Power On By MSCS. The PWR ON LED blinks continually.
	Power Off by MSCS Program. (System ready).
<p>FAN : Normal - LED Off, Abnormal - LED On IF FAN LED is turned on, please check FANs.</p>	

## 4. How to Connect Cables

- Do not connect/disconnect cables while MPDP or other external equipments are turned on.
- First turn off the power all the attached equipment and make connections.
- Make sure the power cord is inserted properly into the power inlet to prevent unexpected pullout of the cord.

### 4.1. Connection of Single MPDP

- MPDP and PC should be connected; a Com Port in a PC and RS-232C IN port in a MPDP is connected with supplied RS-232C cable.
- MPDP On/Off or Screen adjustment can be controlled by MSCS (Multi-Screen Control System).
- ID setting on the backside of MPDP must be identical with the ID setting in MSCS to control MPDP with a PC.
- If you do not have Com Port, you need to use an USB converter for RS-232C. Depending on manufacturers or models, converters may cause malfunction.

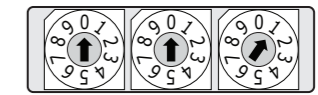
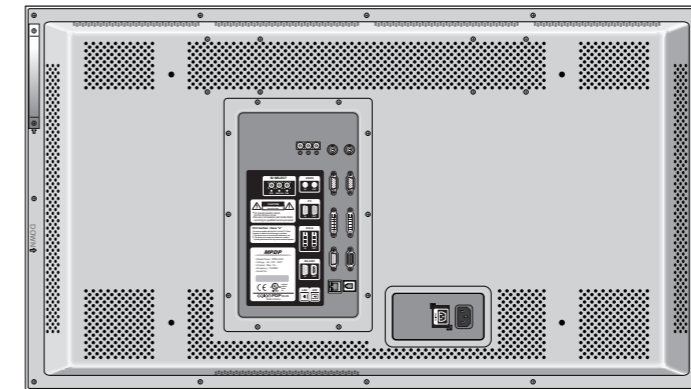

[MPDP ID 1]

- ID switch must be set as ID 1 for one set use.

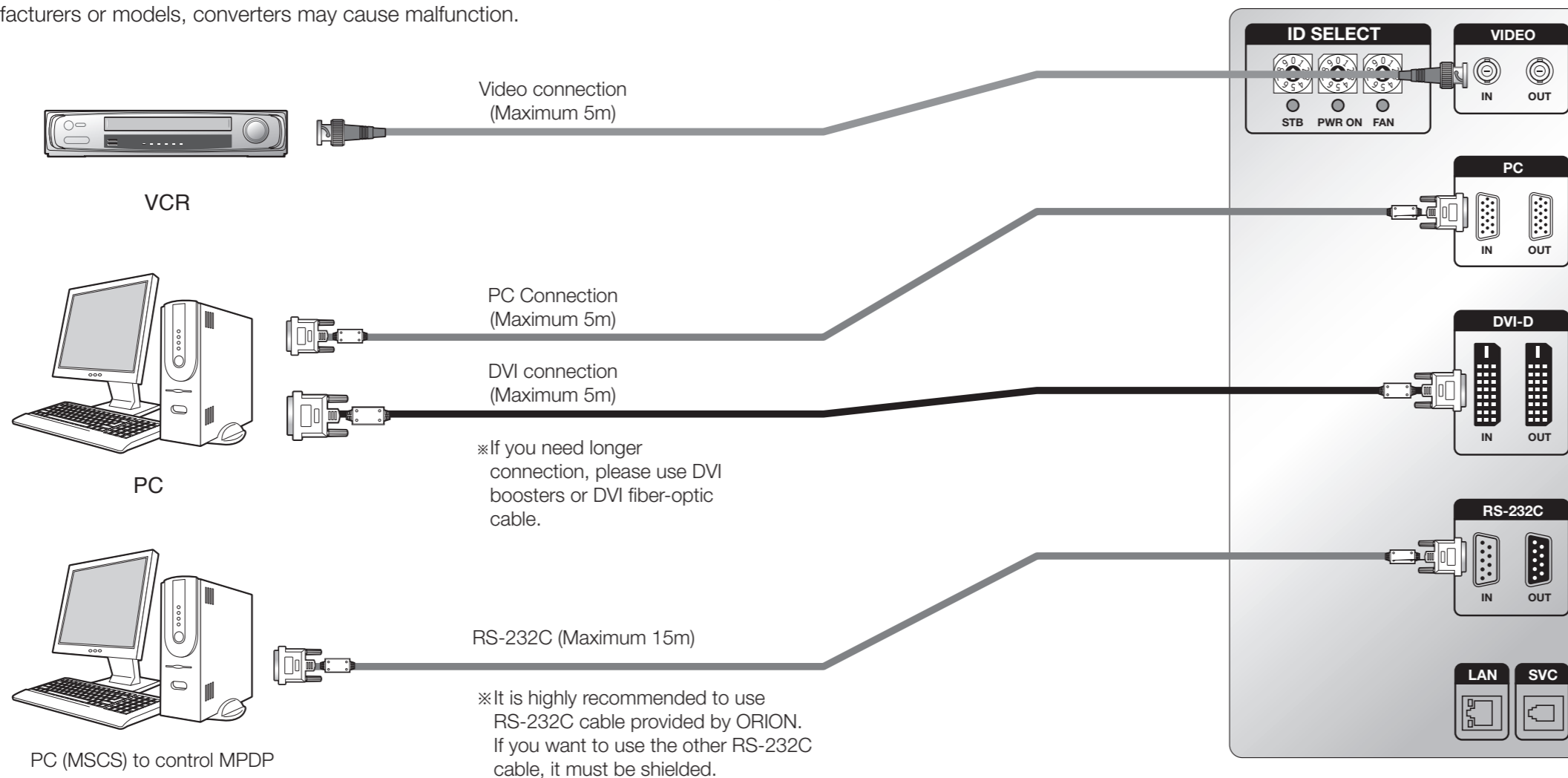

### 4.2. Connection of Multiple MPDP

- Recommended maximum set connection for Multi setting is shown in table below. If you need to connect more than described in the table, you have to use distributors.
- Image quality can be affected by cable or signal quality.

INPUT SOURCE	Resolution	Connection	Remark
DVI	1600 x 1200 x 60Hz	6 sets	HDCP Available
PC	1600 x 1200 x 60Hz	3 sets	
VIDEO	NTSC, PAL, SECAM	6 sets	
RS-232C		30 sets	ORION Cable Only

※ It is highly recommended to use RS-232C cable provided by ORION. If you want to use the other RS-232C cable, it must be shielded.

※ Maximum use of RS-232C with Daisy Chain connection is 30 sets or less, if you need additional connection, use New MFC. (Max 30sets/1 port)

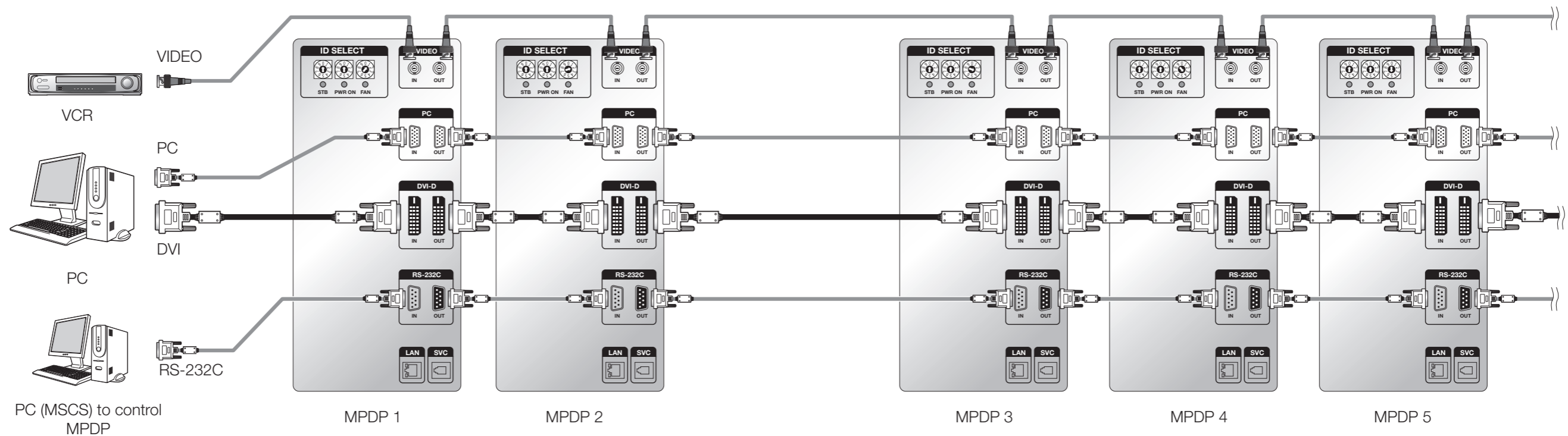
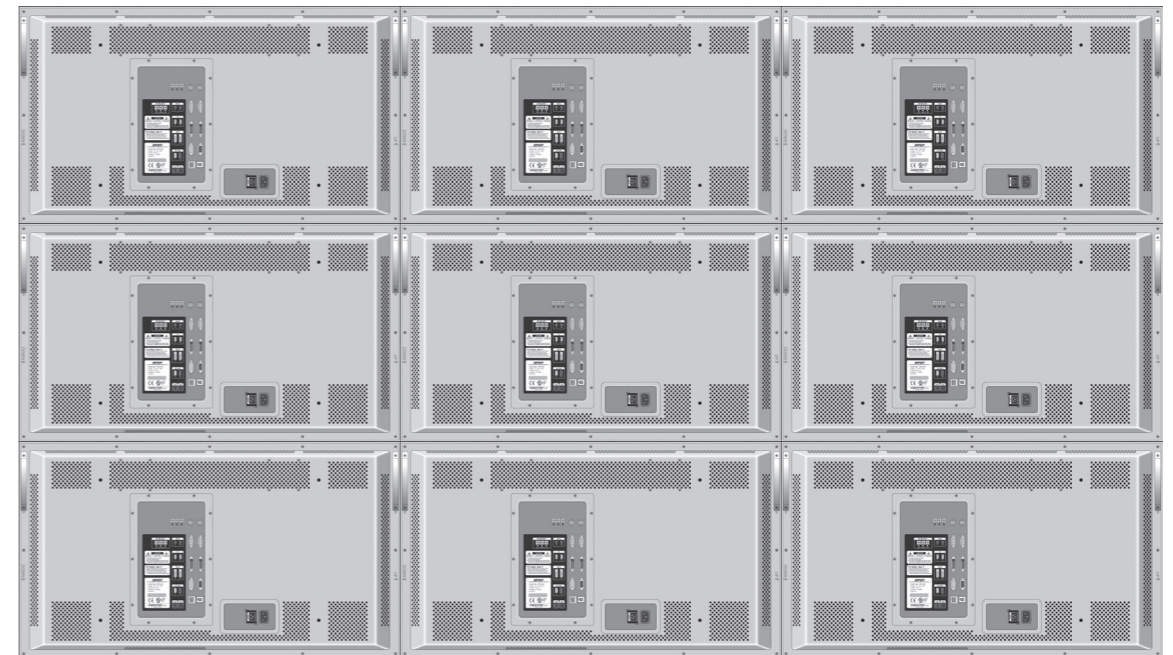

### 4.3. Connection of Control Cable - In case of using MSCS

- Control signal transmission can be connected by 2 different methods. (RS-232C or Ethernet)
- RS-232C and Ethernet connection cannot be used simultaneously.

#### 4.3.1. Connection of RS-232C Cable

- Maximum use of RS-232C with Daisy Chain connection is 30 sets or less, if you need additional connection, use New MFC.(Max 30sets/1 port)

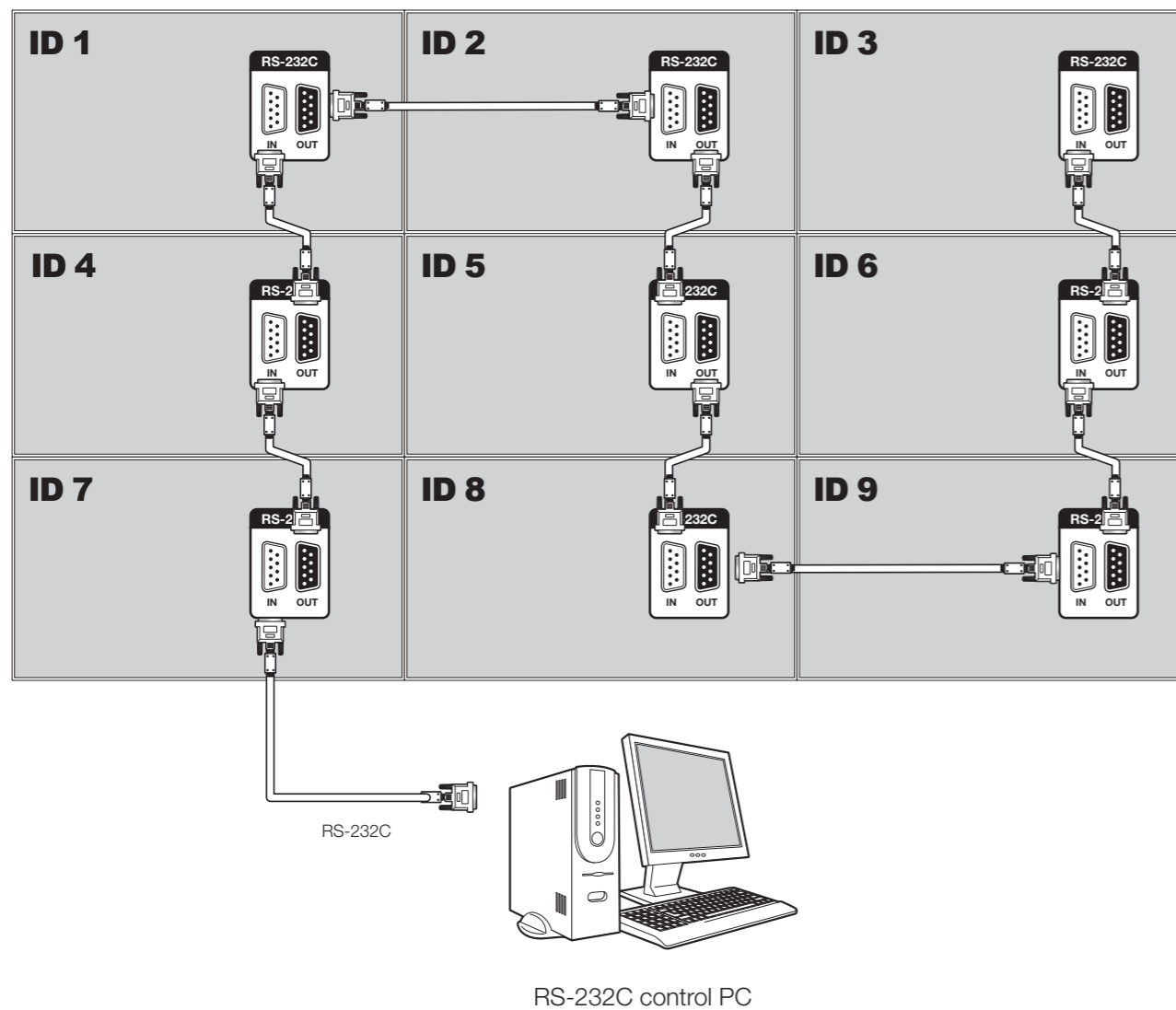

#### 4.3.2. Connection of Ethernet Cable

- In case of Ethernet connection, the control PC should be connected to one of MPDP sets with Ethernet cable. For the connection between the MPDP sets, they should be connected with RS-232C cables.

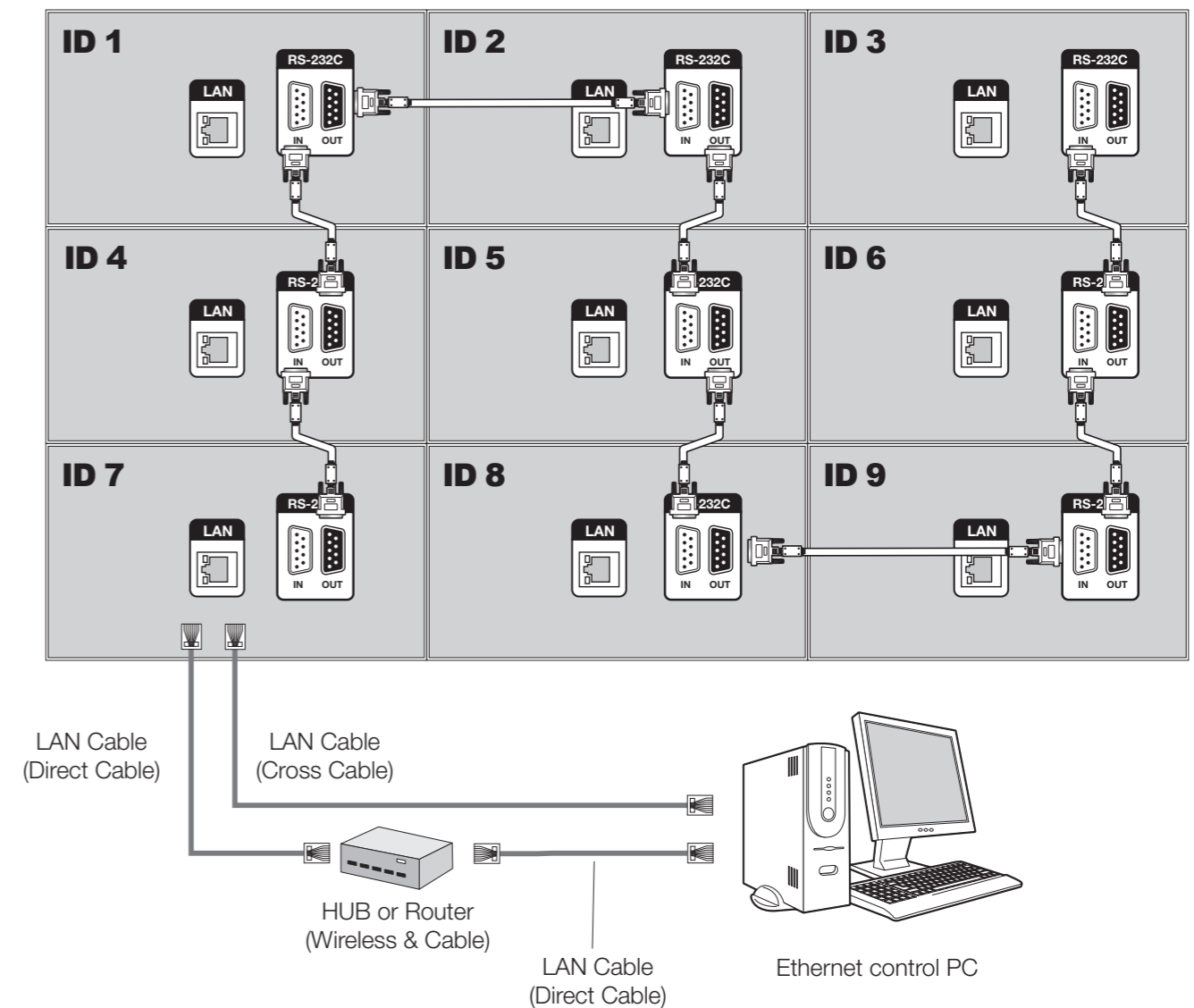

#### 4.4. Connection of Control Cable - In case of using the other control program besides MSCS

※ If you use the other screen control program besides MSCS, the signal cable must be connected via MFC (Multi- Function Controller) of ORION.

- Control signal transmission can be connected by 2 different methods. (RS-232C or Ethernet)
- RS-232C and Ethernet connection cannot be used simultaneously.

##### 4.4.1. Connection of RS-232C Cable

- The RS-232C signal cable must be connected via MFC.
- Maximum use of RS-232C with Daisy Chain connection is 30 sets or less, if you need additional connection, use New MFC.(Max 30sets/1 port)

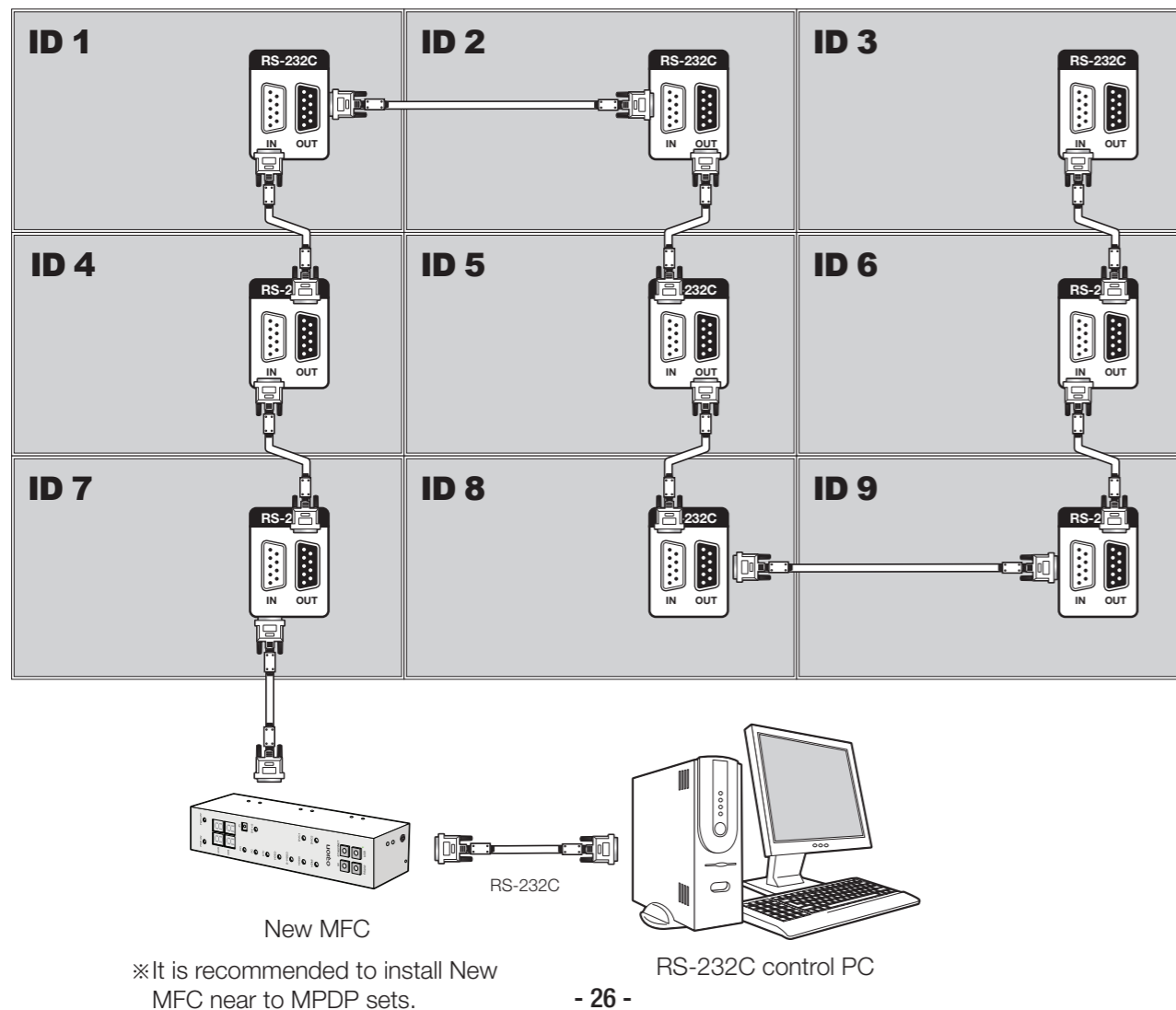

##### 4.4.2. Connection of Ethernet Cable

- If you want to control MPDP sets with Ethernet, PC and MFC can be connected with Ethernet cable and between MFC and the first MPDP set and between the other MPDP sets should be connected with RS-232C cable.

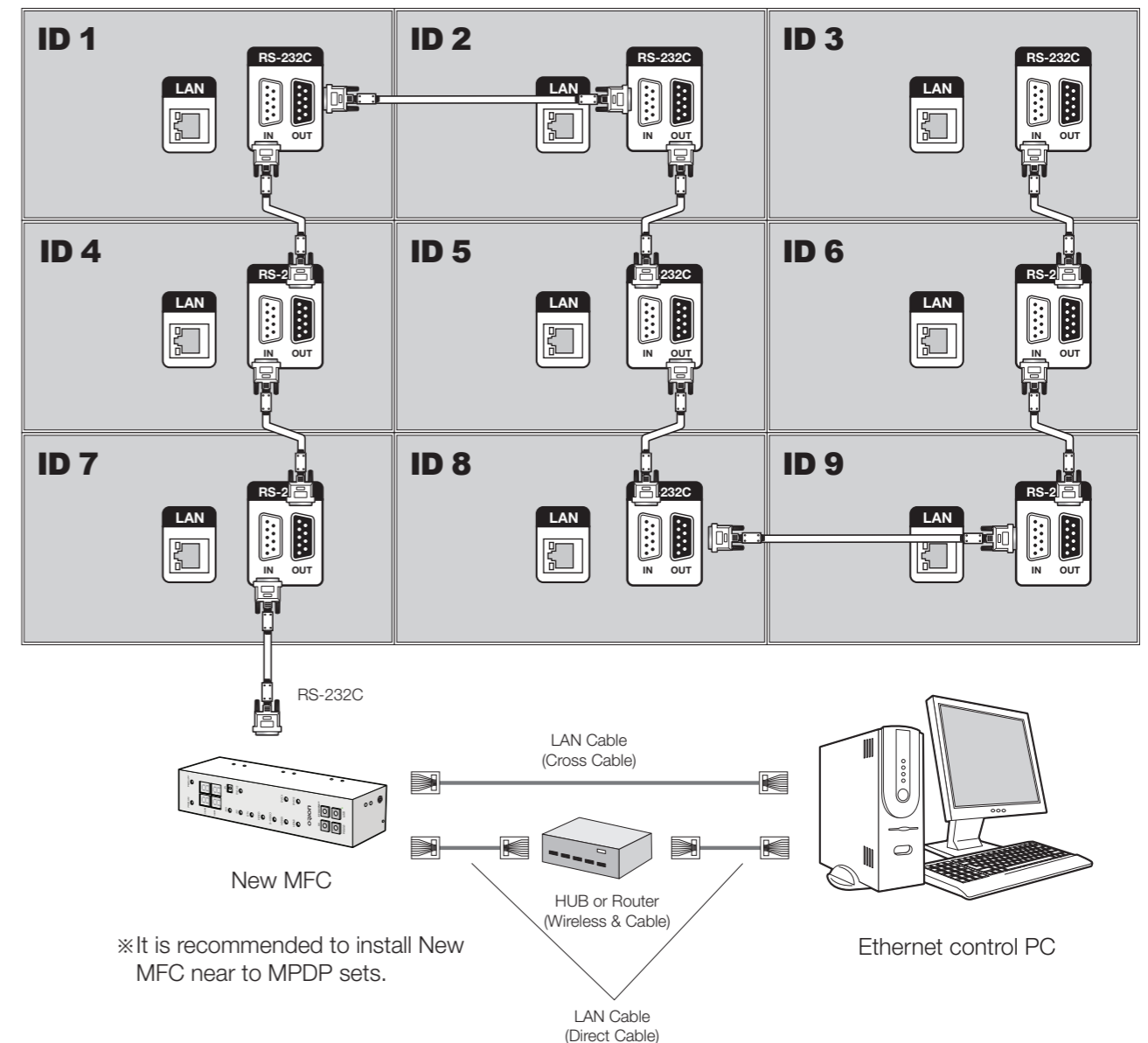

4.5. Connection of DVI cable

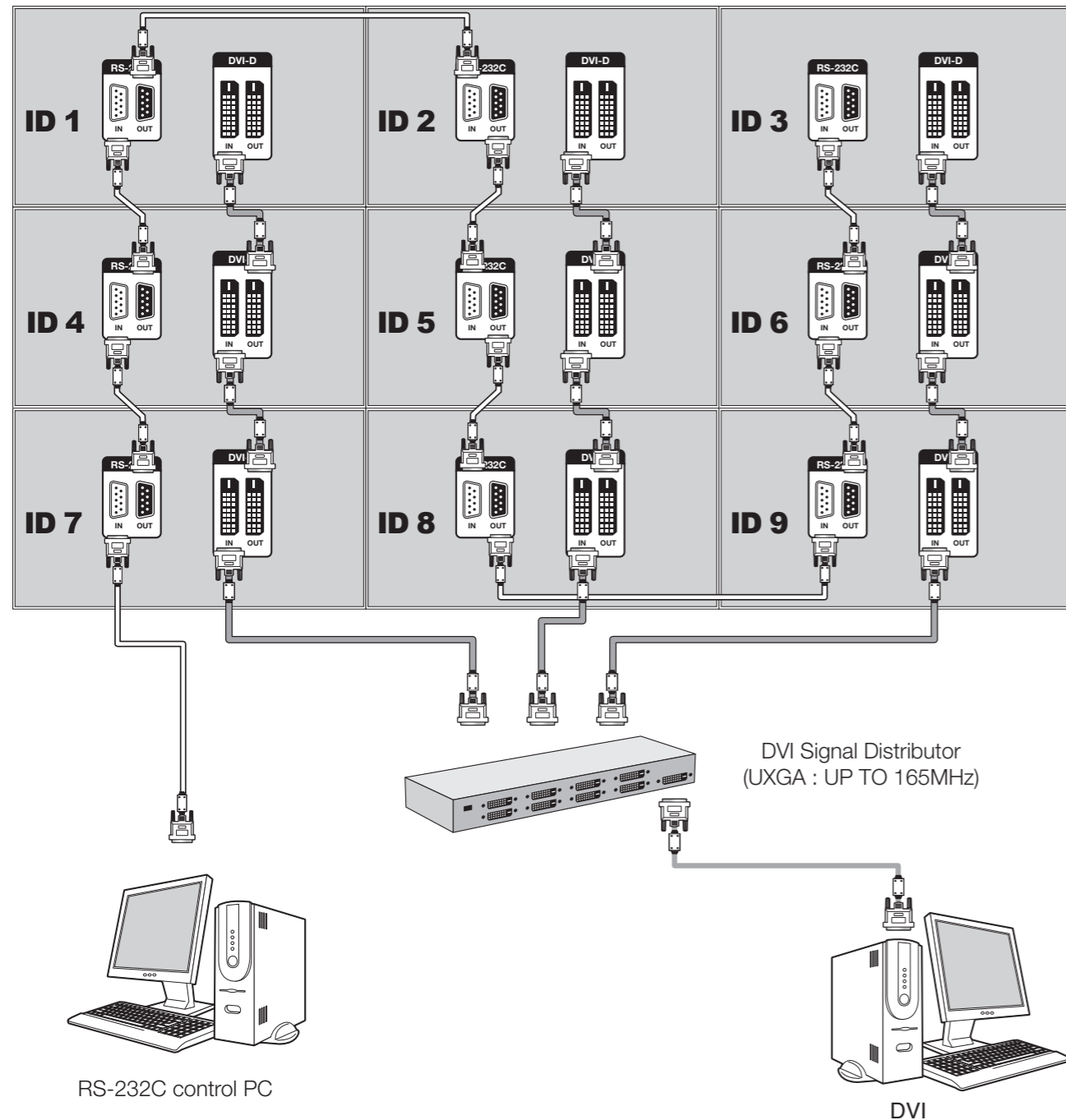

※ Caution for DVI Distributor

If you want to display HDCP (High-bandwidth Digital Content Protection) applied contents, you must use the distributor that supports HDCP function.

4.6. Connection of optional accessory

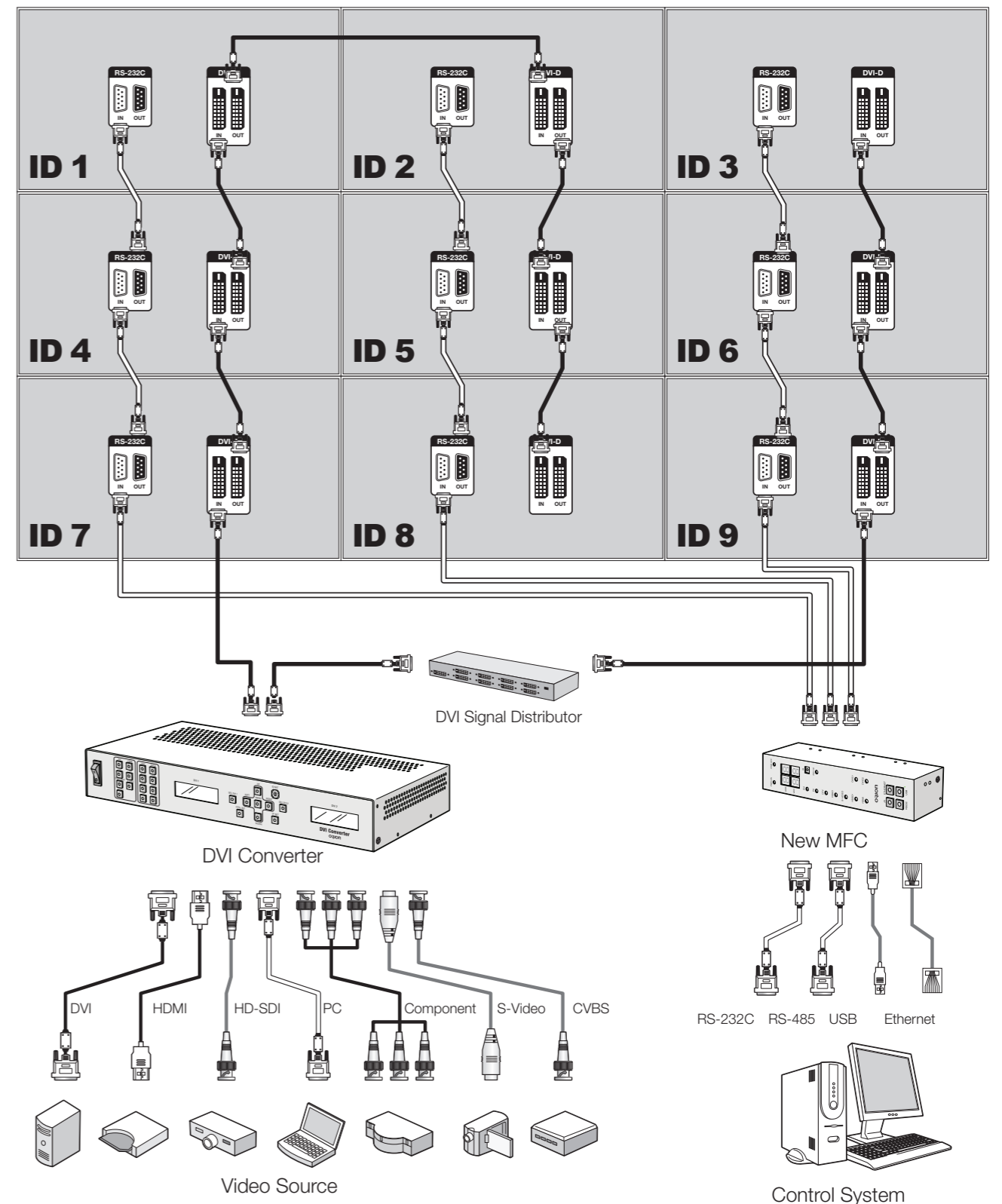



### 4.7. ID setting of X x Y MPDP

- Identity number (ID) indicates the location of each MPDP.
- When you look at the MPDP screens in front of MPDP.

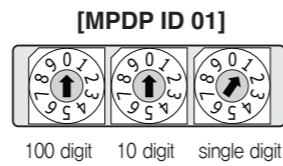

PDP ID 1	PDP ID 2	PDP ID 3	PDP ID 4	PDP ID 5
PDP ID 6	PDP ID 7	PDP ID 8	PDP ID 9	PDP ID 10
PDP ID 11	PDP ID 12	PDP ID 13	PDP ID 14	PDP ID 15
PDP ID 16	PDP ID 17	PDP ID 18	PDP ID 19	PDP ID 20
PDP ID 21	PDP ID 22	PDP ID 23	PDP ID 24	PDP ID 25

Recommended ID of X x Y screens

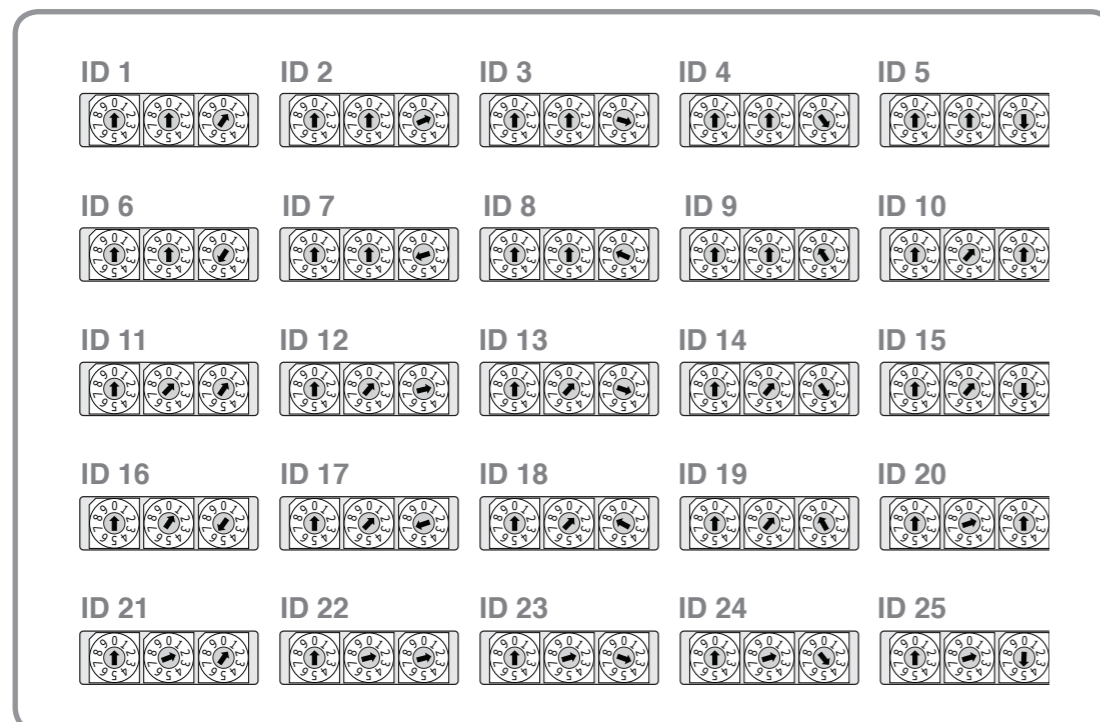

## 5. Setting and operation of MSCS software

### 5.1. MSCS Installation

- Insert the Installation CD.
- You can see following installation start screen.
- Select proper version for your product and start installation

• MSCS supports Windows® 2000, Windows® XP and Windows® Vista, Windows® 7™ only



MSCS Installation start screen.



#### ※ Caution for using MSCS

1. Data for Picture control, Manual Tracking and so forth can be read by clicking the right button of your mouse on the desired MPDP set from MSCS. Please do not use above function together with the other functions.
2. When you off AC power, execute power off by MSCS first and disconnect AC power to save your configuration.

### 5.2. Start MSCS

- MSCS is an application program needed to control MPDP.
- When you execute MSCS for your product at the installation screen, it will create a new folder at *C:/Program File/MSCS* and an icon on your computer screen.
- By double clicking the MSCS icon, the initial screen image of MSCS will be displayed as shown in the picture.



Main Image of MSCS (Multi Screen Control system)

### 5.3. Setting of COM Port

- Com Port connects or disconnects the communication between PC and MPDP.
- Connect MPDP to PC Com Port via RS-232C cable.

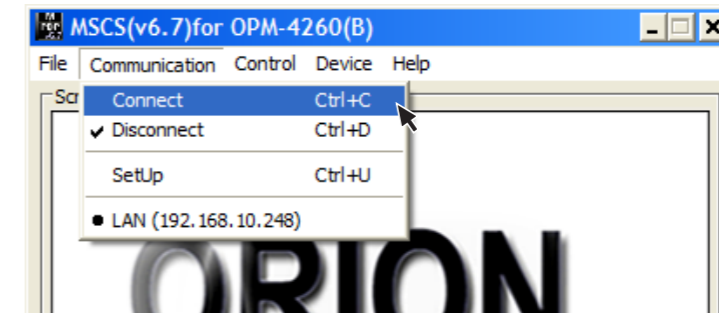

- Go to MSCS Menu -> Communication and set Com Port. Click 'Connect' using mouse or press 'Ctrl+C' using keyboard.
- In order to disconnect communication, click 'Disconnect' using mouse or press 'Ctrl+D' using keyboard.

When you use USB-to-RS-232C converters, you need to set Com Port again, because MSCS uses one of Com Port no. 1 to 30.

※ Available Com Port on the PC is automatically recognized and displayed.

- Com Port Configuration

Baud Rate	115200bps(Fixed)
Data Bit	8Bits
Parity	None
Stop Bit	1Bit
Flow Control	None



**Caution**

- ※ To install MSCS, you need the account for the administrator.
- ※ Check whether Windows Firewall or anti-virus program prohibits the access of MSCS to the IP address of the display.

### 5.4. Setting of LAN Port (In case of connecting to a LAN Hub)

- This function is used to control the MPDP via LAN PORT.
- \* During the setting process, MPDP and control PC should be connected via RS-232C cable only. Do not connect ethernet cable.
- \* After setting process, the control PC should be connected to one of MPDP sets with Ethernet cable only. For the connection between the MPDP sets, they should be connected with RS-232C cables.

#### ■ Network IP setting for MPDP

- 1) Execute the LAN Configurator V1.0 from installation CD.
- 2) Select Com Port and select "OPEN".

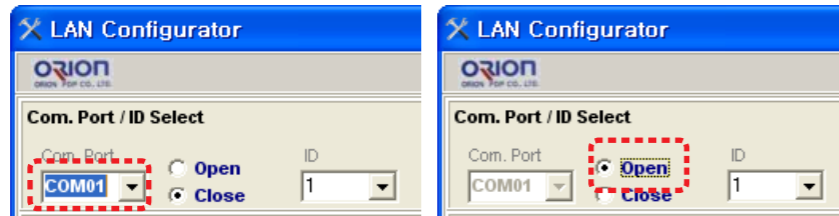

- 3) Select ID of MPDP which you want to control.
- 4) Turn off MPDP.

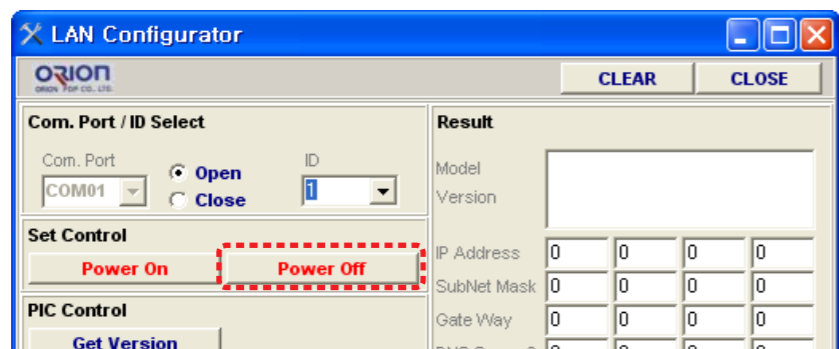
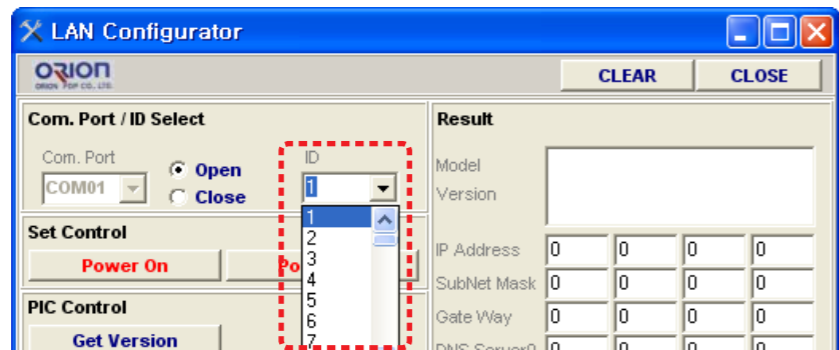

- 5) Type in IP Address.

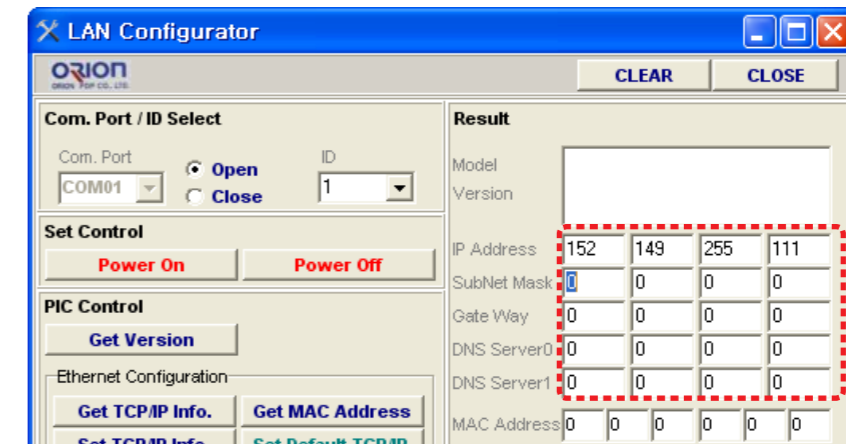

- 6) Click "SET TCP/IP Info".

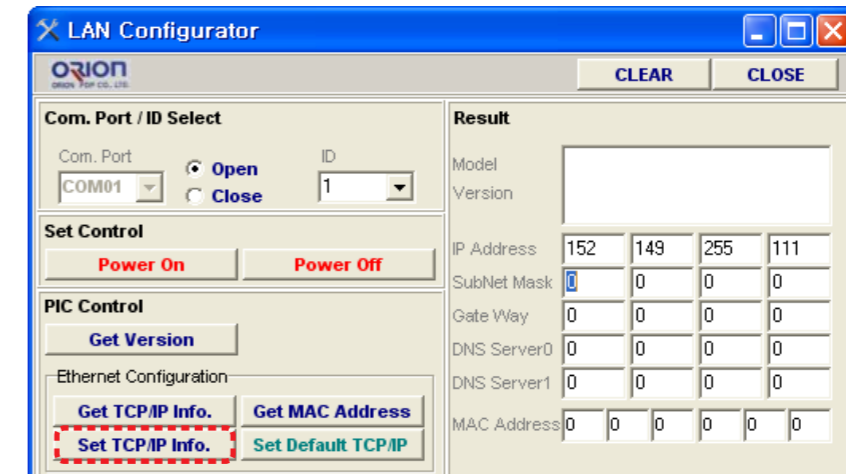

- 7) Click "GET TCP/IP Info." and Confirm the IP Address.

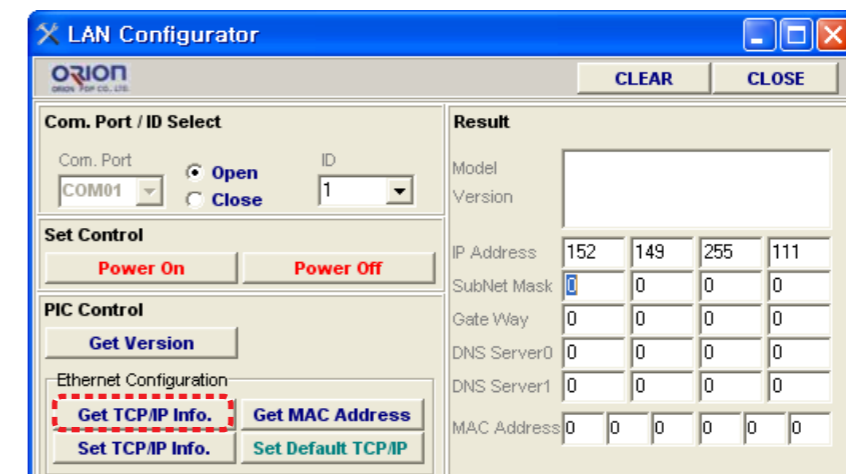

- 8) Close the LAN Configurator V1.0

### 5.5. Setting of LAN Port (In case of connecting directly to user's computer)

■ Check the network informations

- 1) Execute the LAN Configurator V1.0 from installation CD.
- 2) Select Com Port and select "OPEN".

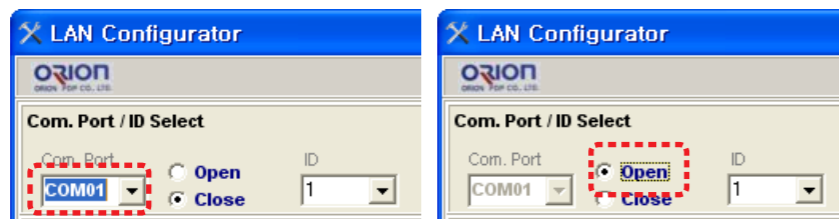

- 3) Select ID of MPDP which you want to control.
- 4) Turn off MPDP.

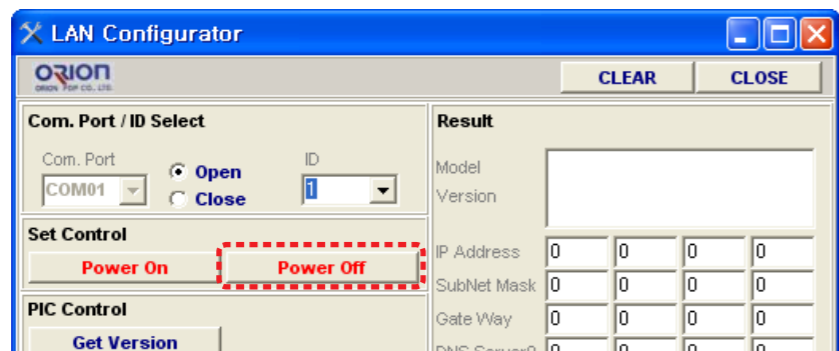
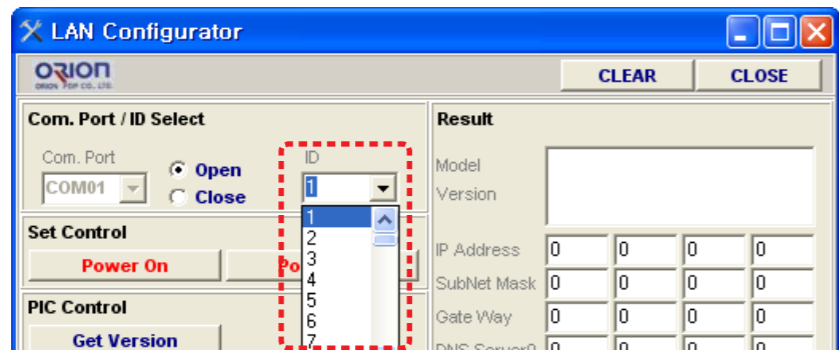

- 5) Click "GET TCP/IP Info." and check the network informations.

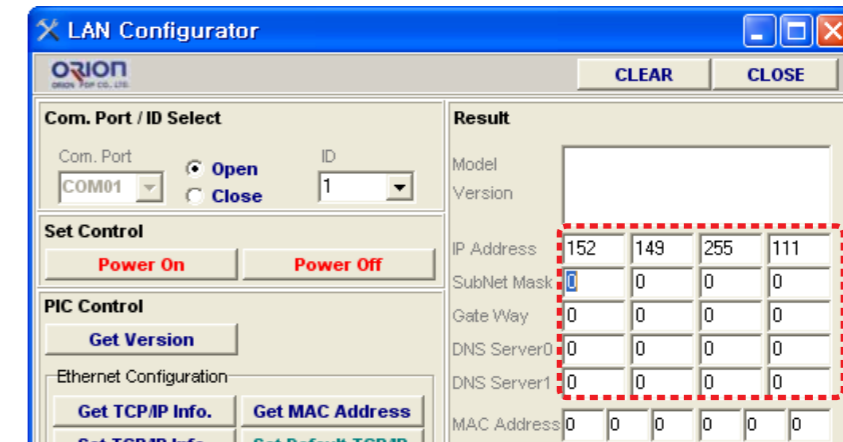

- 6) Input the network information of the user's PC to be identical with MPDP set. However, the final digit of the IP address must be different.

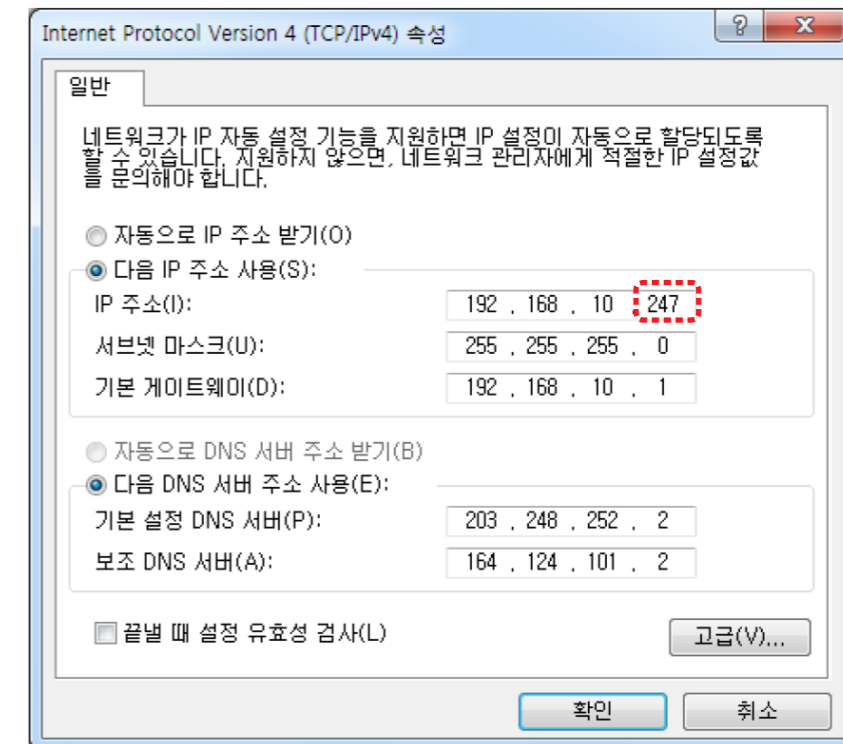

■ Network IP setting for MSCS

- 1) Execute the MSCS.
- 2) Select "Menu->Communication -> Setup" or "Ctrl+U" to start setup.

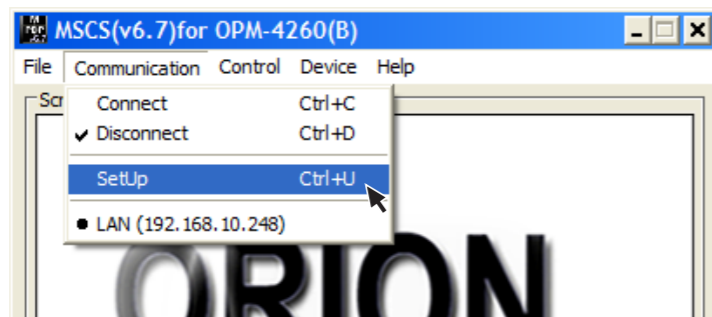

- 3) Select "Socket" radio button.
- 4) Type in IP Address of MPDP.
- 5) Click "Ping Test" to check status of communication.
- 6) Close the Commnication setup window

► Menu Description

- **Serial** : Set the serial communication as a default communication.
- **Com Port** : Set the port of a PC to communicate with MPDP.
- **Baud Rate** : Fixed at 115200bps.  
 ※ Caution: Users cannot change the Baud rate.
- **Socket** : Set the Ethernet LAN communication.
- **Edit Box** : Set the IP address.
- **Port Number** : Fixed as 9761.  
 ※ Caution: Users cannot change the port number.
- **Ping Test**: Test the IP address.
- **Connect** : Connect the communication.

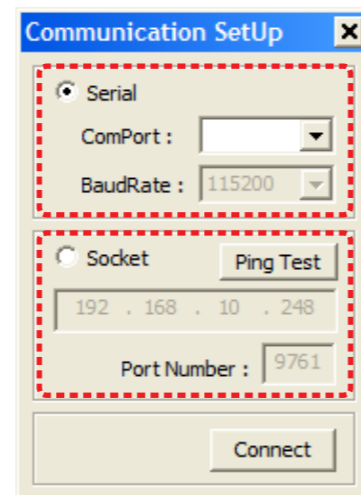

Communication Setup

5.6. "New design/Last design" setting

- You can see following pop-up window for "New design/Last design" when you click "Connect" or press "Ctrl+C" using keyboard after select communication type.

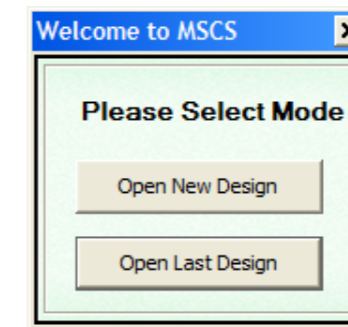

New/Last Design Set

- Click "Open New Design" to prepare new configuration.
- Click "Open Last Design" to go to last design before closing.
- When the connection is successfully completed after setting Com Port, following Message dialog is displayed. The dialog window will be disappeared in 1 second.

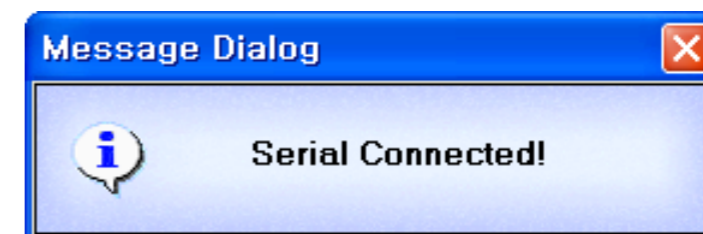

- When the connection is successfully completed after setting Lan Port, following Message dialog is displayed. The dialog window will be disappeared in 1 second.



### 5.7. Multi-screen configuration

#### ■ Input the numbers of X and Y

- X is for the number of row and Y is for column.
- X and Y can be selected within the range from 1 to 15. The maximum MPDP quantity of MSCS control is 100 sets.
- MPDP image of selected numbers of X and Y is displayed in the Screen configuration in one second after setting the number.

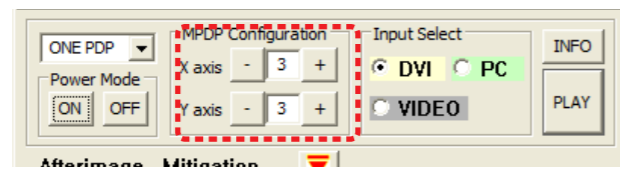

Screen Configuration Setting

### 5.8. Selecting the command transmission method

- **ONE PDP** : Transmit Protocol Command to one MPDP.
- **ALL PDP** : Transmit the Protocol command sequentially to all connected MPDP sets.
- **Broadcast** : Transmit the Protocol command simultaneously to all connected MPDP sets.

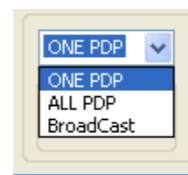

#### ※ INFO :

- Check the resolution of the input source. It is displayed at the upper right corner of the screen.
- Check the signal. If there is no input signal, "No signal" is displayed.

### 5.9. Power On/Off

1) Power On: Press On button in the Power Mode.

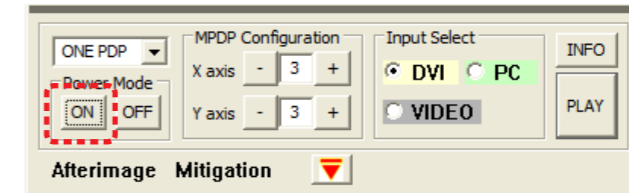

2) Power Off: Press Off button in the Power Mode.

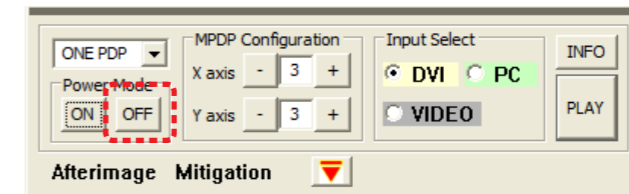

**Caution**

It needs about 10 second standby time before pressing the Power On button if the power is newly connected. Without the standby time, it may cause malfunction. In case of malfunction, disconnect the power plug and connect it again.

3) Power off for Afterimage Mitigation: Power off after displaying a pattern to mitigate the afterimage. Press Afterimage Mitigation button.

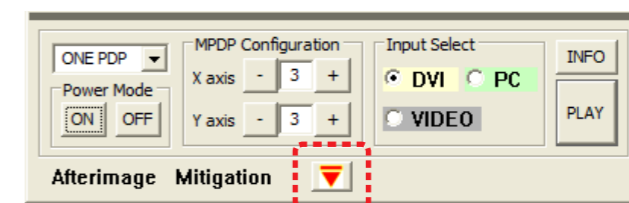

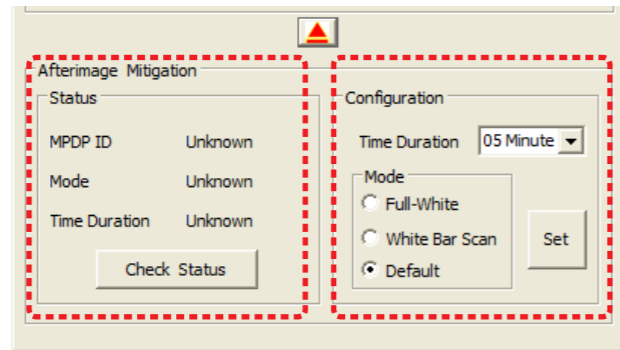

Afterimage Mitigation Menu

**A. Status**

- It indicates the function of Afterimage Mitigation for each PDP.

**B. Configuration**

- 1) Time Duration: Decide the duration time for the display pattern.
- 2) Mode: Select a pattern for Afterimage Mitigation
  - Full White: Display White on the entire screen.
  - White Bar Scan: Display moving white bar pattern on the screen
  - Default: No display



**C. Configuration Step**

- 1) Select PDP set for Afterimage Mitigation  
Select ALL PDP or Broadcast for all PDP sets and One PDP for single PDP set.
- 2) Select the duration time in the Time Duration menu.
- 3) Select a pattern in the Mode menu.
- 4) Complete the configuration by pressing SET button. When you press SET button, following menu window will be displayed. If you want to check the status of each PDP set, press the right button of the mouse and press Check Status button.

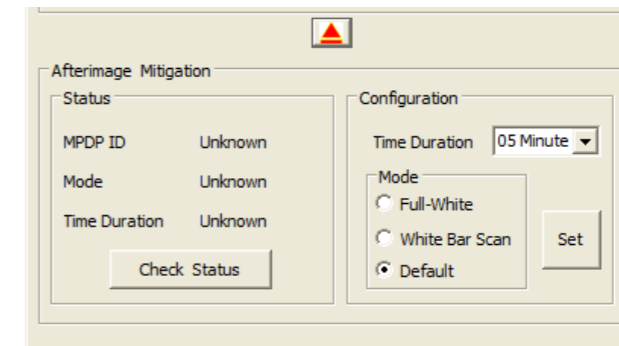

- 5) Press Off button after configuration, Afterimage Mitigation pattern will be displayed for the selected time and the PDP set will be turned off.

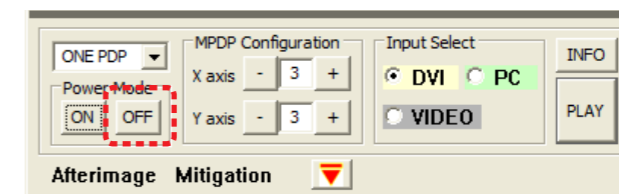

※ This function is for mitigating Afterimage. However, it does not prevent the occurrence of Afterimage. Therefore, it is highly recommended not to display fixed image for long time.

### 5.10. Changing the input source

- Varieties of screen formations are available with screen configuration.
- Select DVI, PC or Video at the Input Select menu.

#### 5.10.1. If you select DVI and click Play button at the Input Select menu, the input source will be changed from PC to DVI .

– In case you do not select a screen and click Play, the input source for the all screen will be changed.

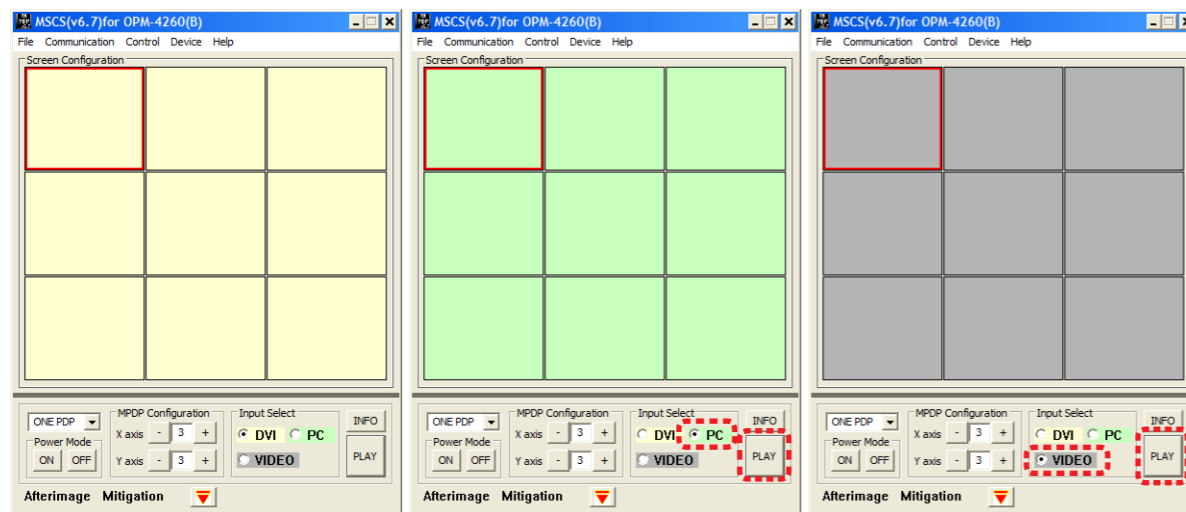

Select DVI at the Input Select menu

※ Input source is not displayed on the MSCS screen, but it is indicated by colors.  
 (DVI : Yellow PC : Green Video : Gray)

#### 5.10.2. Screen formation

- To make various Input-screen formation, select an input source and click the screen you want in the Screen configuration with the left button of the mouse.

1) Select PC at the Input Select menu.

– e.g.) in case PC is selected

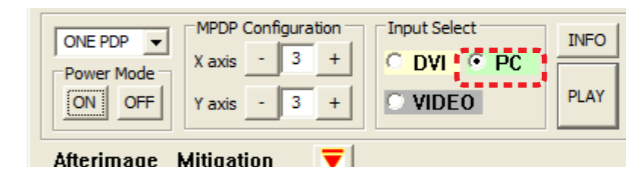

2) Click the screen you want in the Screen configuration with the left button of the mouse.

- Click the screen you want in the Screen configuration with the left button of the mouse.
- DVI screen will be changed with PC.

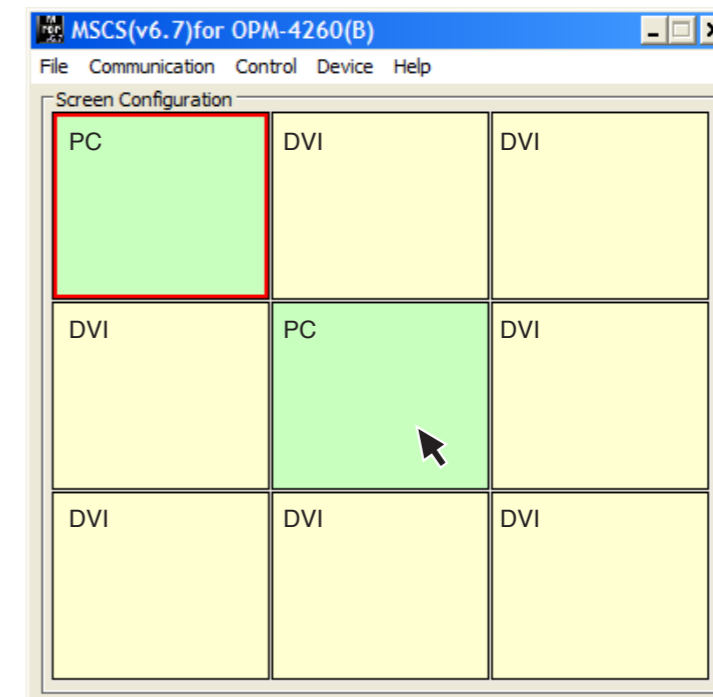



### 5.10.3. Screen Formation with one step.

- You can make various multi-screen formations with simple movement.

1) Select an input source at Source Select menu.

- e.g.) In case you want to select PC

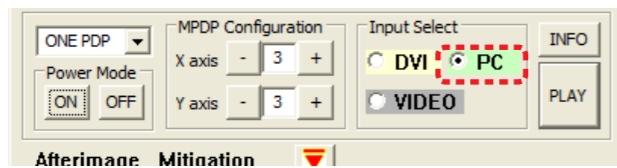

2) Click the screen you want in the Screen Configuration with the left button of the mouse and drag.

- Click the screen you want in the Screen Configuration with the left button of the mouse and drag to the screen you want to include.
- When you stop dragging, selected screens will be changed to PC automatically.

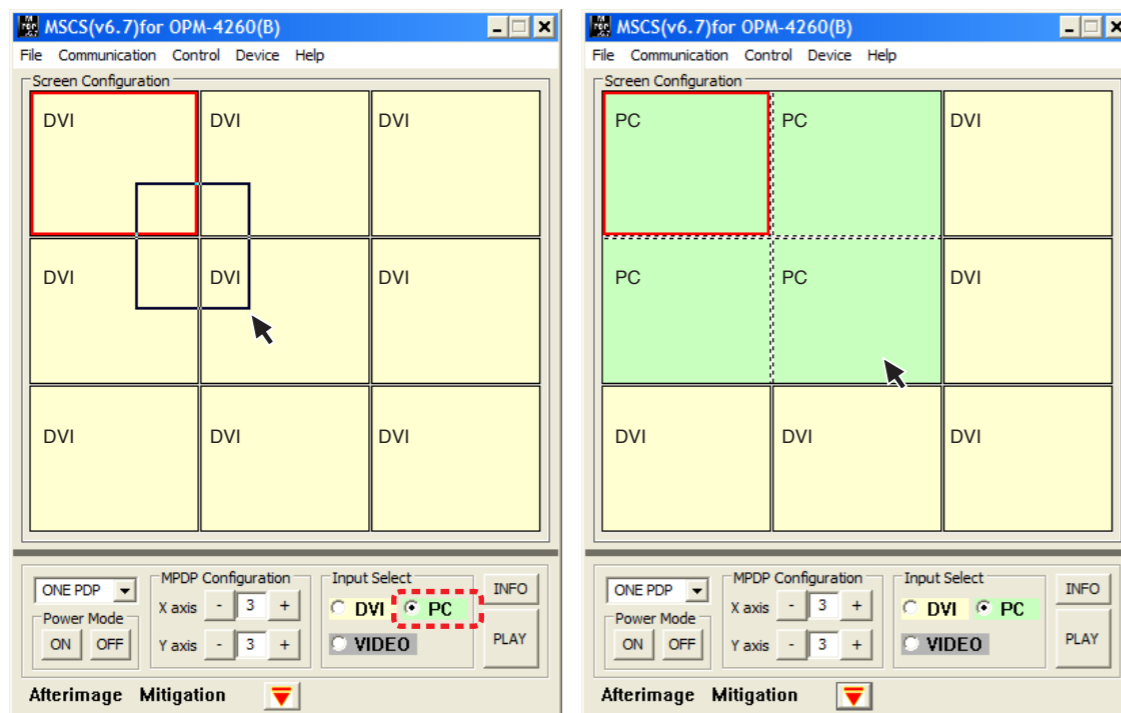

### 5.11. Slide Control

- MPDP configuration that users can choose is displayed repeatedly.
- To use Slide Control, go to MSCS Menu -> Control -> Slide Control or press "Ctrl+S" using Keyboard.

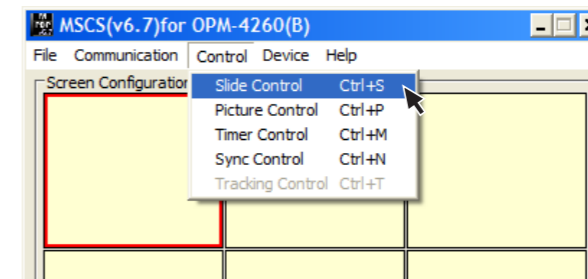

1) Make a desirable configuration in "Screen Configurations"

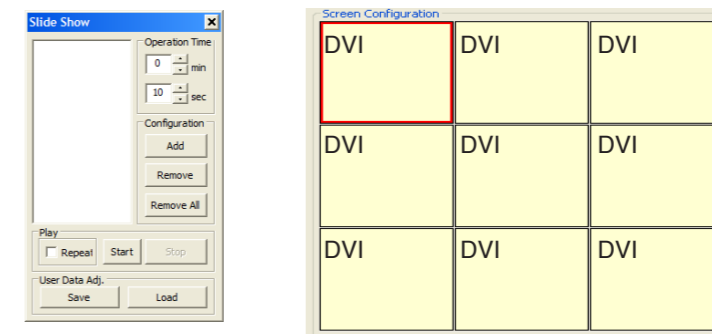

2) Set "Operation Time" in "Slide Control"

- Click "Add" button to save configuration.
- The range of "Operation Time" is from 10 seconds to 1 hour.

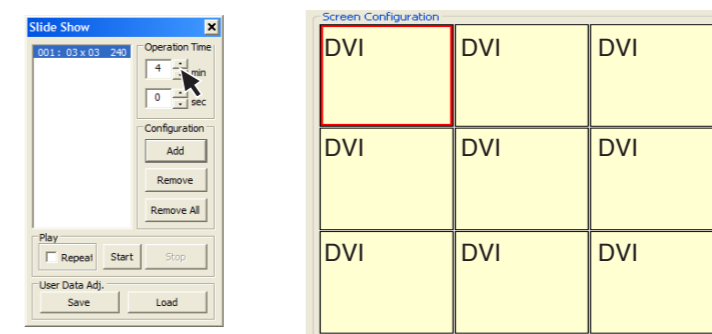

3) Save various screen configurations in the same way.

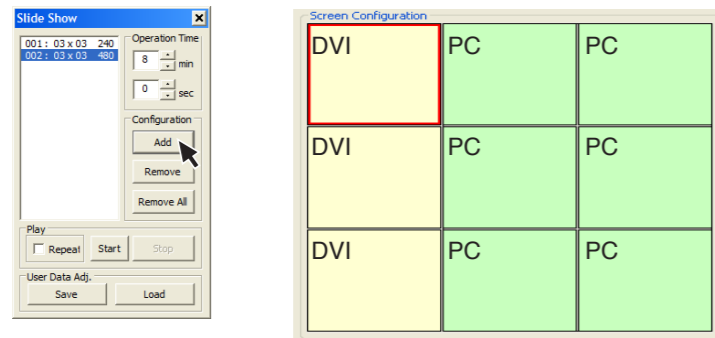

4) Click "Slide Start" to display saved screen configurations.  
 - Saved screen configurations are displaying for preset time.

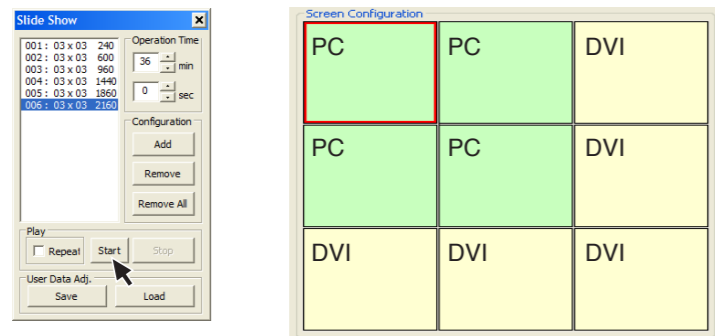

5) Check "Repeat" to display saved configuration repeatedly.

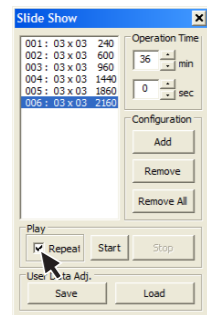

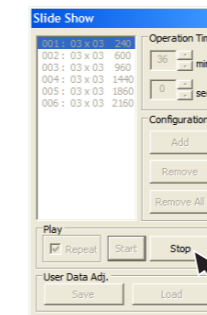

6) Click "Stop" button to end "Slide Control"

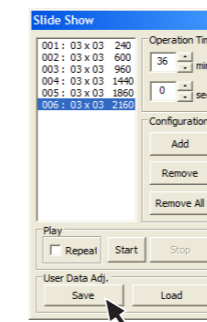

7) Save or Load the slide configuration

- Click "SAVE" button to save user added Slide configuration as "\*.ssd" file.
- Click "LOAD" button to open saved "\*.ssd" file.



**Caution**  When you load "Slide File", previous slide configuration and new slide configuration must be identical. If they are different, the file cannot be loaded. So, revise the new slide file configuration as previous configuration or save as new file.

- ※ To view the saved screen configuration, select the list from "List Box."
- ※ Saved screen protocol is transmitted to MPDP by double clicking the list.

### 5.12. Picture Control

- Register values related to display of MPDP can be changed.
- To use Picture Control, go to MSCS Menu -> Control -> Picture Control or press "Ctrl+P" using Keyboard.

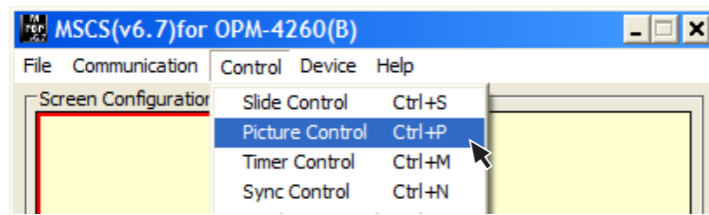

- In order to control display values, input values directly in "Edit Box" and press Enter key. Or click +/- button using mouse.
- Click "Exit" button or press "Ctrl+X" using keyboard to close "Picture Control" window.
- **Color Temp** : Change the color temperature of the screen
  - Normal : Initial setting. Proper for normal video image view.
  - Studio : Low Color temperature. Proper for broadcasting purpose.
- **Brightness** : The range of "Brightness" you can adjust is 0 to 100.
- **Contrast** : The range of "Contrast" you can adjust is 0 to 100.
- **Sharpness** : The range of "Sharpness" you can adjust is 0 to 28.
- **User Data** : Users can adjust color impression with white screen and save or load the adjusted value.
  - Save - Save User's data file (\*.pdt)
  - Load - Load User's data file (\*.pdt)

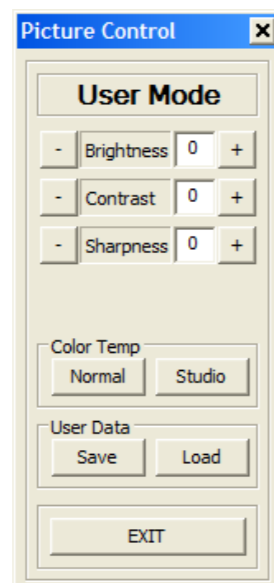

### 5.13. Timer Control

- Users can decide the time of turning on or off MPDP set by timer control.
- To use this function, click Menu -> Control-> Timer Control or use 'Ctrl +M' keys from the keyboard.

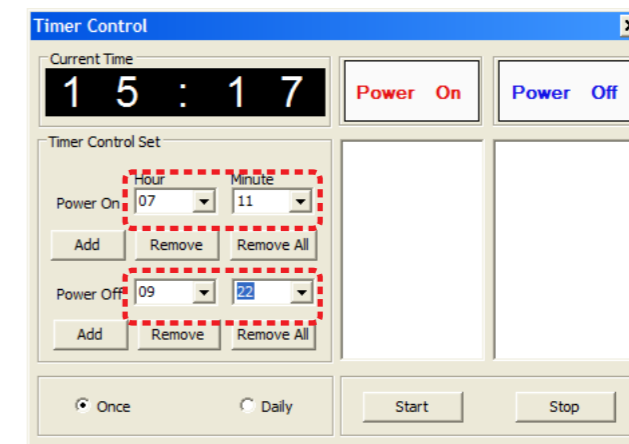
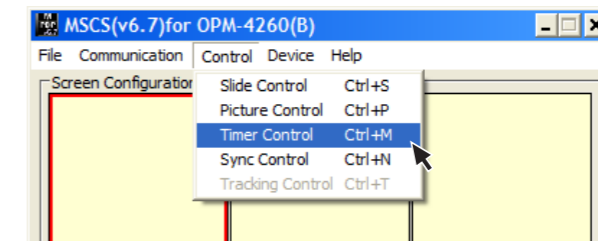

Timer Control Dialog

- How to set the time of power on or off.
  - I. Select Hour and Minutes of turn on or off
  - II. After setting Power On/Off time, click "Add" button to add it to Power On/Off List Box. You can save up to 10 settings for Power On/Off. Also, you can delete the saved settings in the List Box one by one with "Remove" button. If you delete all the settings, click "Remove All" button.
  - III. Select once for one time use and Daily for daily use, then click 'Start'
  - IV. Power on or off signal will be transmitted to MPDP at the time of user set.
- Time Dialog must be activated to use Timer function

### 5.14. Sync Control

- It reduces the flashing effect for MPDP.
- Select Menu -> Control -> Sync Control or press "Ctrl + N" to execute Sync Control.

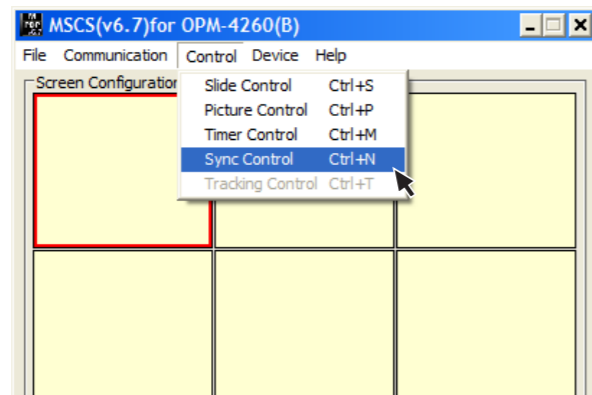

- MPDP ID for Sync Correction, Sync Correction Mode and Time will be displayed at the Sync Correction Status window.
- Select "Auto" for automatic Sync correction.
- Select "Manual" for manual Sync correction.
- Sync Correction time can be selected (Range: 0~255)
- Sync Correction time will be reset as "0" when the Correction mode is changed from "Manual" to "Auto."
- If Sync Correction Time is changed by user during "Auto" mode, it will be turned to "Manual" mode automatically.

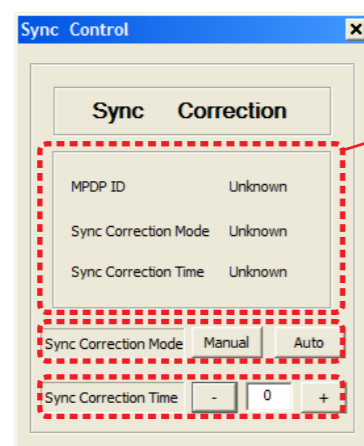

Sync Correction Status

### 5.15. Tracking Control

- Alignment adjustment is available when input source is PC.

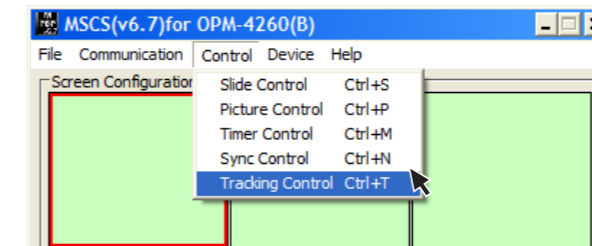

- Go to "Control" in menu bar -> Tracking Control or press "Ctrl+T" using keyboard to run "Tracking" window.
- Press "Tracking Auto" button in order to run auto tracking.
- In case alignment doesn't work through "Tracking Auto" command, user can tune finely through "Manual".
- Manual Tracking enables users to set Frequency, Phase, LineStart and PixelStart.
- Select panel ID which you want to adjust alignment.

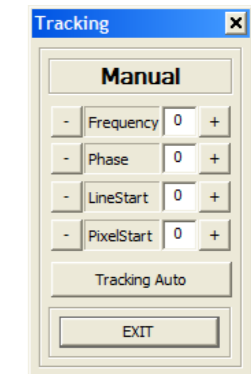

Tracking Manual Window

- Detail adjustment steps are as follows.
  - 1) Tune "Phase" until the vertical lines are clearly adjusted..
  - 2) Tune "LineStart" to adjust vertical alignment. "PixelStart" for horizontal alignment.
  - 3) Adjust "Frequency" if alignment is still wrong. If you adjust "Frequency", repeat step 1) and 2) to fit alignment. Adjustable range is as follows
    - The range of "Frequency" you can adjust is -50 to 50
    - The range of "Phase" you can adjust is 0 to 63
    - The range of "Linestart" you can adjust is -23 to 10
    - The range of "Pixelstart" you can adjust is -50 to 40
- Click "EXIT" button or press "Ctrl+X" using keyboard to close "Tracking" window.

※ When "Tracking" windows is on display, users cannot display "Picture Control" window.

※ Even when "Tracking" window is on display, selecting panel ID is available by clicking right button of mouse.

### 5.16. ORION Homepage log on and Version Information

- In order to move to Orion website, go to "Help" of menu bar ->"OrionDisplay HomePage".

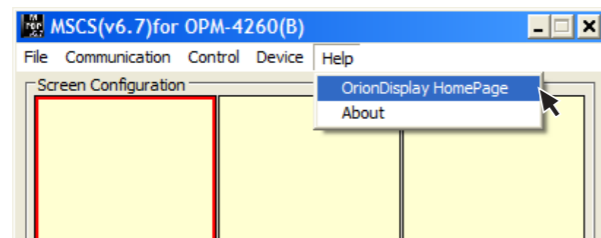

ORION Homepage Log on

- Go to "Help" of menu bar -> "About" to check MSCS.

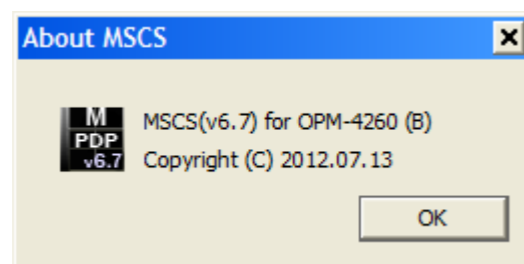
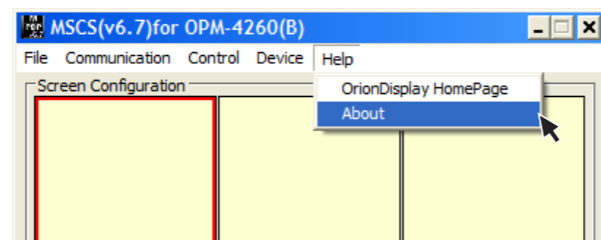

Checking MSCS Version

## 6. Control Method of optional accessory

### 6.1. New MFC

#### (1) New MFC Connection

- 1) Connect power of New MFC
- 2) Connect female D-sub of New MFC to the Com port in the computer with RS-232C cable.
- 3) Connect male D-sub of New MFC to the RS-232C port in MPDP with RS-232C cable.
- 4) Install the New MFC at the location of good Remote controller reception.
- 5) Set the number of the connected MPDP units in advance. The number can be set only by the Remote controller.

※ For the additional information refer to the "New MFC manual"

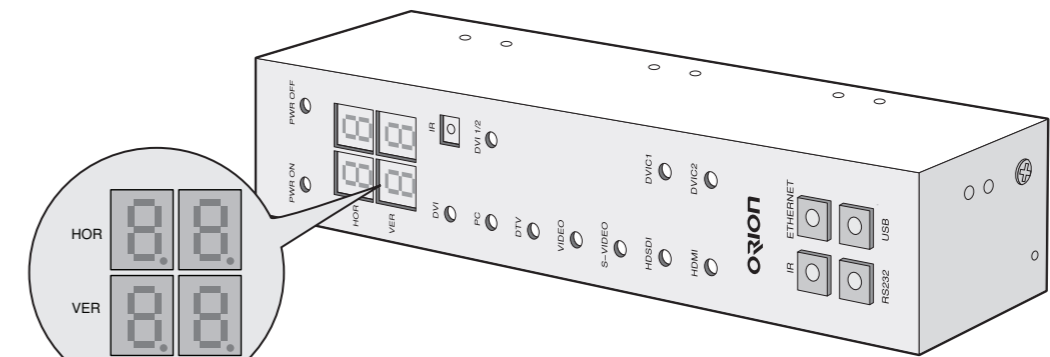

MPDP "N x M" Configuration

New MFC Front

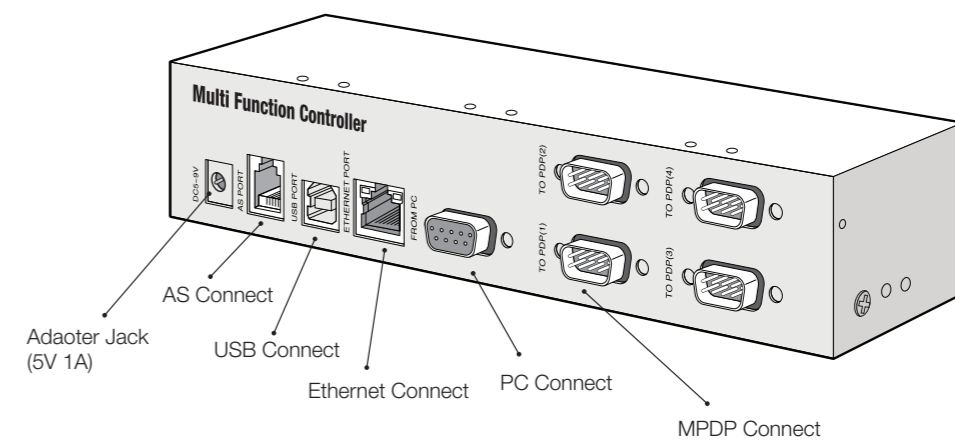

New MFC Rear

(2) MPDP Set Configuration (e.g. X:5 sets x Y:6 sets)

**Horizontal configuration**



1. Press SET button .



2. Press Left and Right buttons sequentially to enter the horizontal configuration mode.

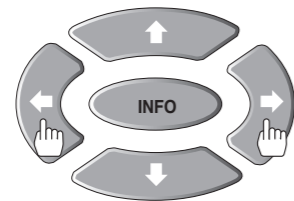

3. When the 2 LEDs at lower right corner of each 7-segment of lower line in the New MFC are turned on, the horizontal configuration mode is started.

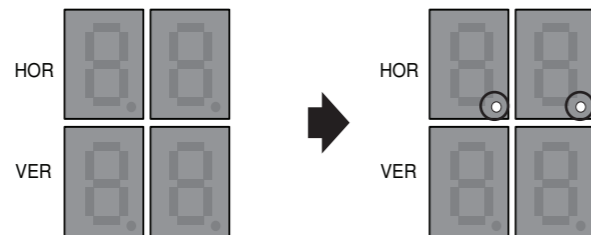

4. Use the number buttons to set the numbers of MPDP sets in horizontal line.  
-e.g. If you want to set 5 for horizontal number, press "0" for ten's place and "5" for one's place.

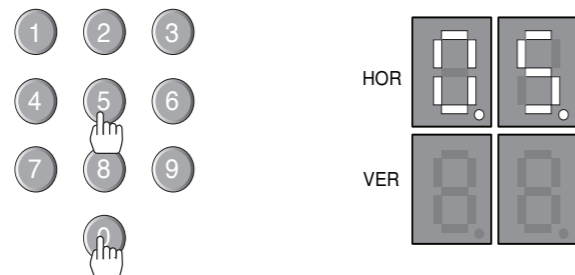

5. Pres SET button to finish the horizontal configuration mode.

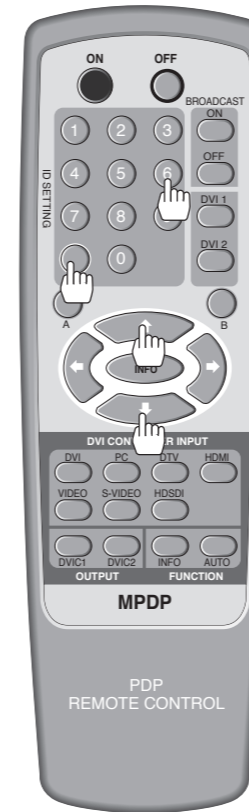

**Vertical configuration**

1. Press SET button.



2. Press Up and Down buttons sequentially to enter the vertical configuration mode.

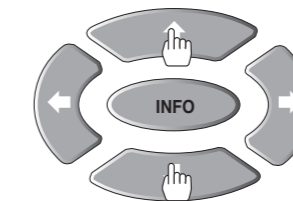

3. When the 2 LEDs at lower right corner of each 7-segment of lower line in the New MFC are turned on, the vertical configuration mode is started.

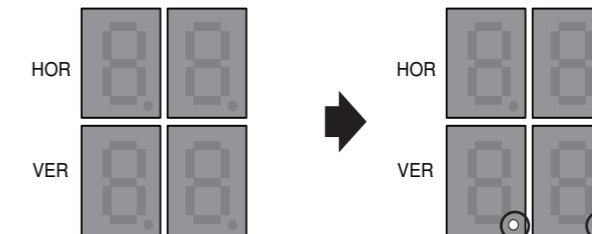

4. Use the number buttons to set the numbers of MPDP sets in vertical line.  
-e.g. If you want to set 6 for vertical number, press "0" for ten's place and "6" for one's place.

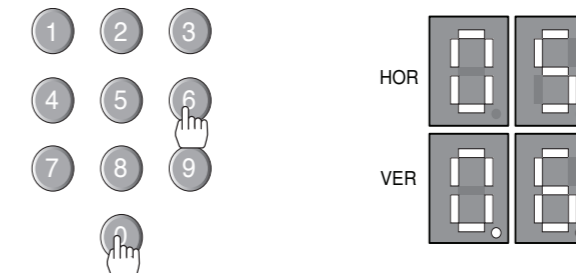

5. Pres SET button to finish the vertical configuration mode.



## 6.2. DVI Converter

- To use DVI Converter, go to MSCS Menu -> Device -> DVI Converter or press "Ctrl+V" using Keyboard.

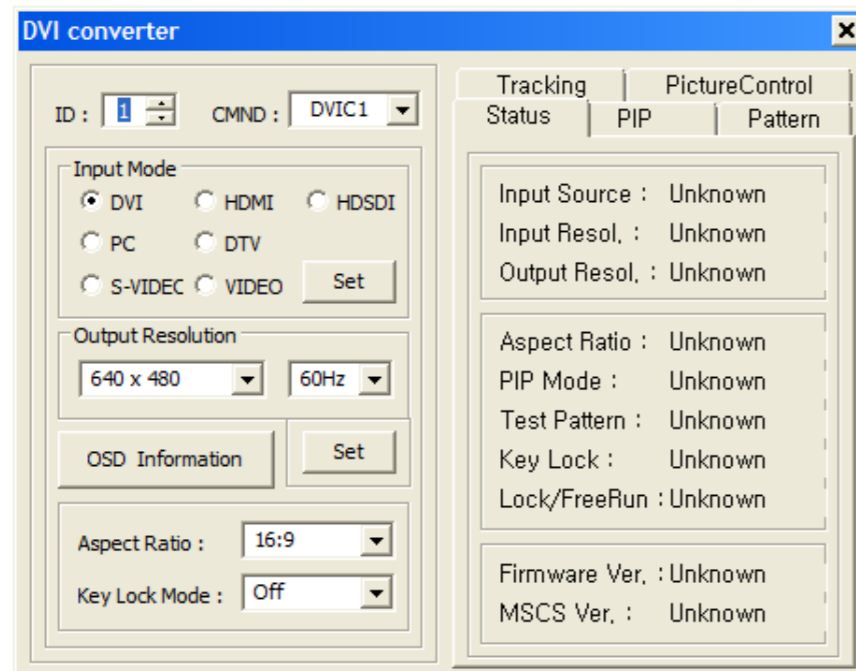
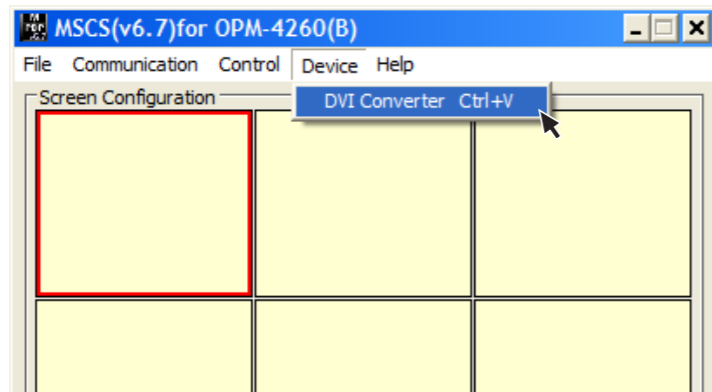

DVI Converter Dialog

### (1) ID

- Set the ID of DVI Converter. The ID can be selected from 1 to 9.

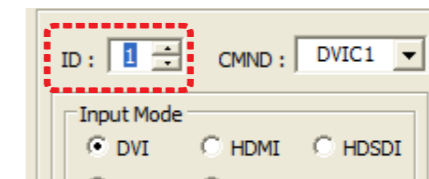

### (2) CMND

- Select the channel of DVI converter to control.
- One of DVI Channel 1(DVIC1), DVI Channel 2(DVIC2), and ALL DVI Channel can be selected.

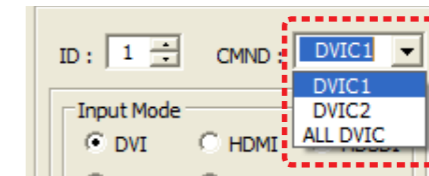

### (3) Input Mode

- Select the input mode of DVI Converter.
- One of DVI, HDMI, HSDSI, PC, DTV, S-VIDEO, and VIDEO can be selected.
- Set** : Select one of 7 Input Modes and press "Set".

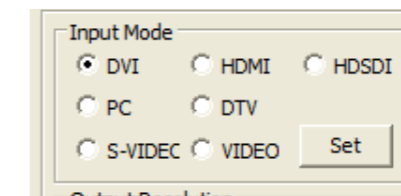

#### (4) Output Resolution

- Set the output resolution of DVI Converter.

Resolution	frequency
640 x 480	60Hz / 85Hz
800 x 600	50Hz / 60Hz / 85Hz
853 x 480	50Hz / 60Hz
1024 x 768	60Hz / 85Hz
1280 x 1024	50Hz / 60Hz
1600 x 900	50Hz / 60Hz
1600 x 1200	50Hz / 60Hz
1706 x 960	60Hz
1920 x 1080p	50Hz / 60Hz

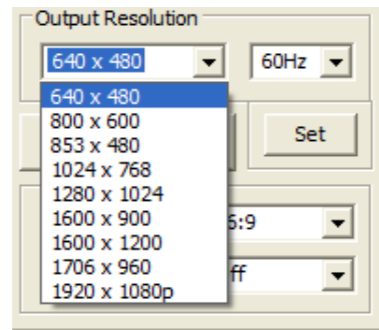

- **Set** : Set the output resolution.

#### (5) OSD Information

- The DVI Converter input mode and input resolution are displayed on the screen.

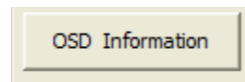

#### (6) Aspect Ratio

- Set or change the screen ratio (Horizontal: Vertical)
- **16 : 9** : Set the screen ratio as 16:9 wide screen.
- **4 : 3** : Set the screen ratio as 4:3
- **LB(Letter Box)** : Expand the screen image to remove the black patterns at the top and bottom portions of the screen.
- **LBS(Letter Box Subtitle)** : Expand the screen with the subtitle to the top portion. (The bottom portion remains with black pattern)

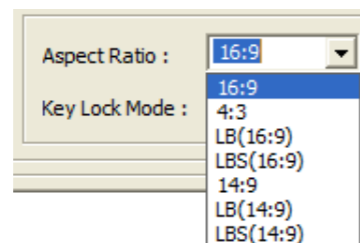

#### (7) Key Lock Mode

- Lock the front key of DVI Converter not to turn On or Off.

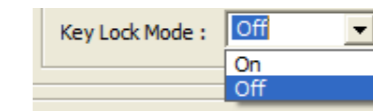

#### (8) Status

- Display the DVI Converter status (Input Source, Input Resolution, Output Resolution, Aspect Ratio, PIP Mode, Test Pattern, Key Lock, FreeRun/Lock, Firmware Version, MSCS Version information)

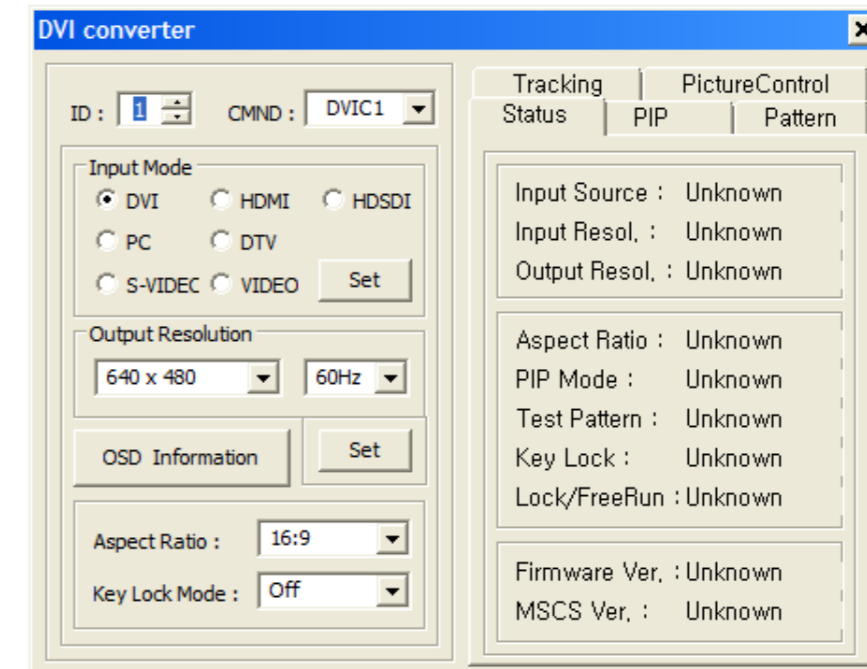



**(9) Picture Control**

- Control the Brightness, Contrast, Sharpness, Color, and Tint of the DVI Converter.
- **Brightness** : The range of "Brightness" you can adjust is 0 to 100.
- **Contrast** : The range of "Contrast" you can adjust is 0 to 100.
- **Sharpness** : The range of "Sharpness" you can adjust is 0 to 28.
- **Color** : The range of "Color" you can adjust is 0 to 100.
- **Tint** : The range of "Tint" you can adjust is 0 to 90.
- **Firmware Default** : Initialize the adjusted values to the default values.

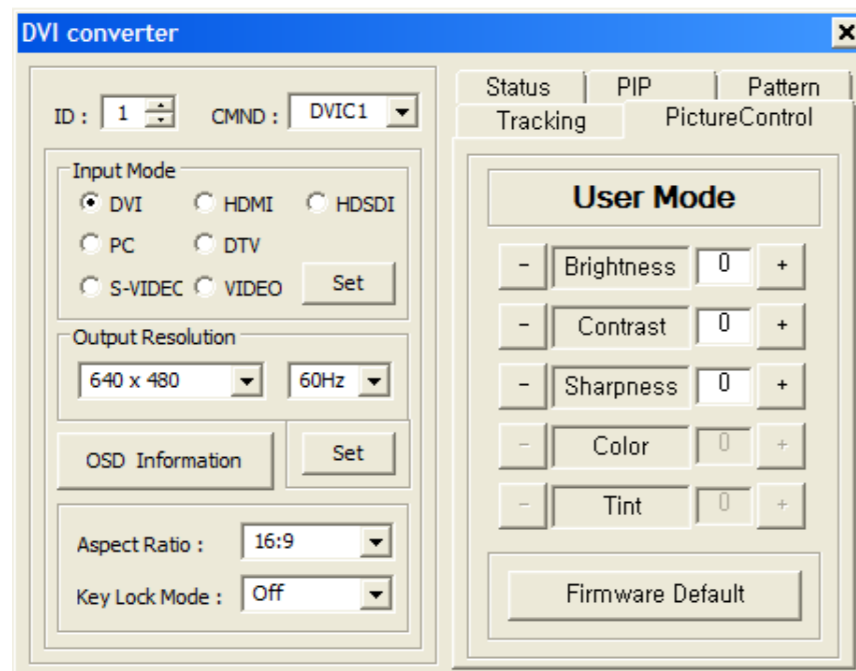
**(10) Pattern**

- Select the Test Pattern (Red, Blue, 8-Color, 16-Gray, Green, White, White (10%), Screen)
- **Set** : Set or change the Pattern.

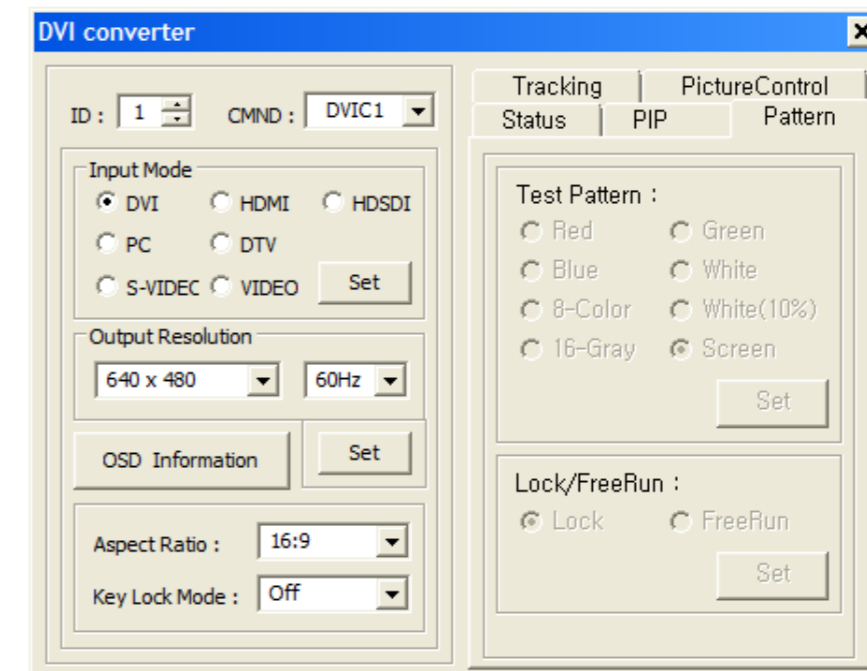
**(11) Lock/FreeRun**

- **Lock** : Default setting. It is used when MPDP is configured as the default display. If the vertical frequency of input signal and out signal is identical, output is generated according to vertical synchronization of input signal.
- **FreeRun** : This function is used when the default display is not MPDP and screen image is not displayed. It generates its own output vertical frequency regardless of input signal. If screen image is displayed, use Lock mode.
- Lock/FreeRun can be configured by the keypad of DVI converter besides MSCS. While Menu OSD is not displayed, FreeRun mode can be selected by pressing UP key and Lock mode by DOWN key.

**(12) Tracking**

- Control the Screen size, sharpness, and position of DVI Converter for PC input mode.
- In case alignment doesn't work through "Tracking Auto" command, users can tune finely through "Manual Tracking".
- "Manual Tracking" window enables users to set Frequency, Phase, LineStart and PixelStart.
- Detail adjustment steps are as follows.
  - 1) Tune "Phase" until the vertical lines are clearly adjusted..
  - 2) Tune "LineStart" to adjust vertical alignment. "PixelStart" for horizontal alignment.
  - 3) Adjust "Frequency" if alignment is still wrong.  
If you adjust "Frequency", repeat step 1) and 2) to fit alignment.  
Adjustable range is as follows
- **Frequency** : The range of "Frequency" you can adjust is -50 to 50
- **Phase** : The range of "Phase" you can adjust is 0 to 63
- **Linestart** : The range of "Linestart" you can adjust is -23 to 10
- **Pixelstart** : The range of "Pixelstart" you can adjust is -50 to 40
- **Auto Tracking** : Automatic alignment for DVI Converter screens.
- **Auto Calibration** : Automatic color control for DVI Converter screen.

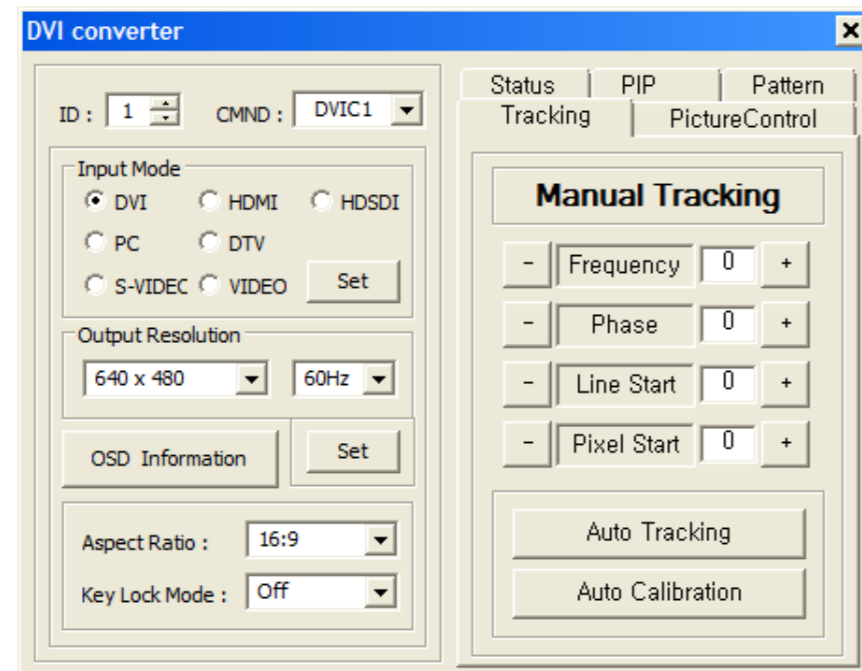
**(13) PIP( Picture In Picture )**

- A variety of images can be displayed with the PIP function of DVI converter. To activate PIP, click "PIP" in the Mode. The position of sub-picture can be controlled by clicking - / + buttons increase or decrease the number or directly type in the numbers at Edit box.
- Various input sources can be used. To set the sub-input, click the sub-input combo box and select sub-input.
- Main screen and sub-screen can be swapped with the PIP Swap function. Press "ON" button at the right side of "PIP Swap." If you want to return to previous screen, press "OFF" button at the right side of "PIP Swap."
- **Mode** : Normal mode - Normal screen without PIP (PIP Off)  
PIP mode-Sub-screen is displayed at the lower right corner of the screen. (PIP On)
- **Position** : Horizontal - Adjust the horizontal location of PIP. Adjustable range 0~100  
Vertical - Adjust the vertical location of PIP. Adjustable range 0~100
- **Sub Input** : Set the input for PIP. One of DVI, HDMI, HDSDI, PC, DTV, S-VIDEO, and VIDEO can be selected for sub-input.
  - ※ According to the main input, the sub-input can be restricted. If the main input is a digital input such as DVI, HDMI or HD-SDI, the sub-input should be an analog input such as PC, DTV, S-VIDEO or Video. If the main input is an analog input the sub-input should be a digital input.
- **PIP Swap** :OFF - Return to previous locations of swapped Main Source Input screen and Sub Source Input screen.  
ON - Exchange the locations of Main Source Input screen and Sub Source Input screen.

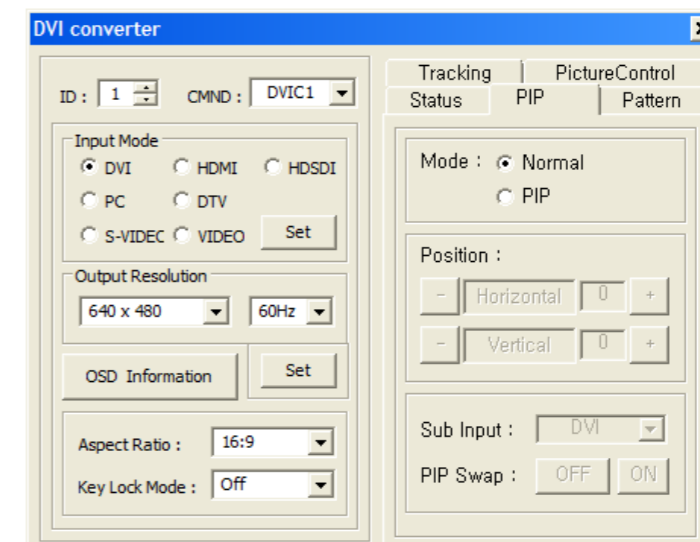

# 7. MSCS Protocol

## 1. Introduction

This chapter contains the communication protocol between PDP and its control devices such as computer for better use of the product. However, it does not include detailed technical matters. It rather focuses on the brief functional explanation and communication protocol.

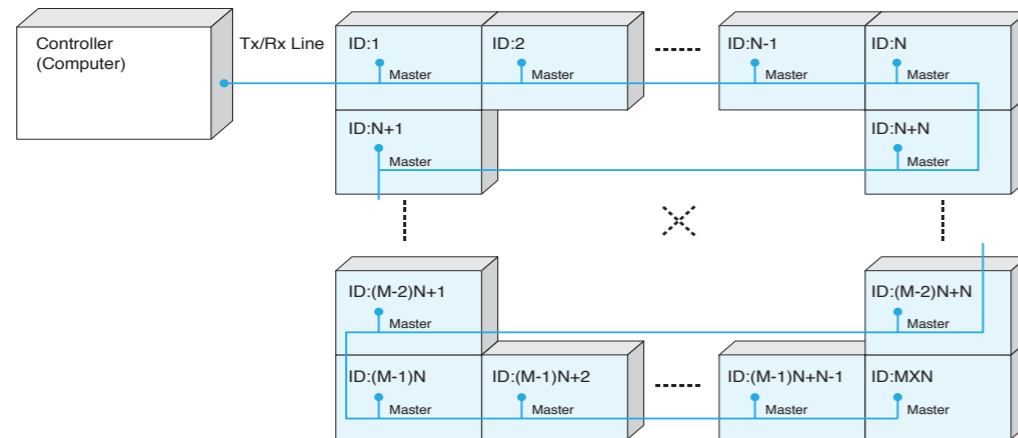

※ The connection can be variable based on environment or the users' intention.  
< Communication connection diagram >

### 1.1. Communication Setting

- Transmission & Reception type: Asynchronous Serial Communication
- Connection type: Daisy Chain
- Baudrate : 115200
- Data Bits : 8
- Parity : None
- Stop Bits : 1
- Flow Control : None

## 2. Protocol Format

### 2.1. Send To PDP

STX	Command	Length	Data	ETX
1 byte	1 byte	1 byte	Variable	1 byte

ID	Master	Other Data
1 byte	1 byte	N byte

- This is how to send commands to PDP. Only the set of the designated ID is working according to the "Command." But, if the "ID" value is "0", all MPDP sets are working according to command as "Broadcast".
- STX(0x02): The initial code. It means the beginning of Protocol. (Fixed value)
- Command: Code for actual operation. (Variable)
- Length: the length of "Data" area. (Variable: 0~255)
- Data: the areas for "ID" and the other Data (Variable)
- ID: It is a code to distinguish PDP sets. Its range is "0" to "255". If the ID is "0," it means Broadcast command.(variable)
- Master(0x01) : This is the scaler code.
- ETX(0x03): The end of the code. (Fixed value)

### 2.2. Receive From PDP

STX	CMD	Length	Data	Check Sum	ETX
1 byte	1 byte	1 byte	Variable	1 byte	1 byte

  

ID	Master	Other Data
1 byte	1 byte	N byte

- Response by a certain command from the designated set among MPDP sets. The difference from "Send to PDP" is "Check sum".
- STX(0x02): The initial code. It means the beginning of Protocol. (Fixed value)
- Command: Code for actual operation. (Variable)
- Length: the length of "Data" area. (Variable: 0~255)
- Data: the areas for "ID" and the other Data (Variable)
- ID: Set identification (0~255) (Variable)
- Master(0x01) : This is the scaler code.
- Check sum: execute "Not" operation after adding all the values in "STX-Data" area.
- ETX(0x03): The end of the code. (Fixed value)

#### - Communication Sequence

- \* Wait for 50msec for response after sending the command. If there is no response, it is recommended to resend the command.
- \* It is recommended that not sending the other command or changing input resolution during command transmission.

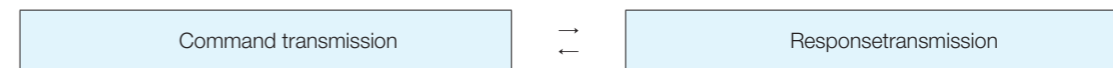

## 3. Command

### 3.1. Power On

- Command for Power On: Operative status
- CMD : 0x40
- It is available only during Power Off(Stand-by) status.
- Send to MPDP

A. Normal command

	STX	CMD	Length	Data		ETX
				ID	Master	
Value	0x02	0x40	0x02	Variable	0x01	0x03

\* ID range(Program): 0x01(1) ~ 0xFF(255)

B. Broadcast command

	STX	CMD	Length	Data: ID	ETX
Value	0x02	0x40	0x01	0x00	0x03

\* Make all PDP do the same operation. But, there will be no return communication. (One way command)

#### - Receive from MPDP

	STX	CMD	Length	Data		Check Sum	ETX
				ID	Master		
Value	0x02	0x40	0x02	Variable	0x01	Variable	0x03

\* ID range (Program): 0x01(1) ~ 0xFF(255)

\* Check sum: execute "Not" operation after adding all the values in "STX-Data" area.

### 3.2. Power Off

- Command for Power Off : Stand-by status
- CMD : 0x41
- It is available only during Power On (Operative) status.
- Send to MPDP

A. Normal command

Value	STX	CMD	Length	Data		ETX
				ID	Master	
	0x02	0x41	0x02	Variable	0x01	0x03

\* ID range(Program): 0x01(1) ~ 0xFF(255)

B. Broadcast command

Value	STX	CMD	Length	Data: ID	ETX
	0x02	0x41	0x01	0x00	0x03

\* All PDP will do the same operation simultaneously. But, there will be no return communication. (One way command)

#### - Receive from MPDP

Value	STX	CMD	Length	Data		Check Sum	ETX
				ID	Master		
	0x02	0x41	0x02	Variable	0x01	Variable	0x03

\* ID range (Program): 0x01(1) ~ 0xFF(255)

\* Check sum: execute "Not" operation after adding all the values in "STX~Data" area.

### 3.3. Power off for Afterimage Mitigation

- Command for Power Off : Stand-by status
- CMD : 0x89
- It is available only during Power On (Operative) status.
- Send to MPDP

A. Normal command

Value	STX	CMD	Length	Data				ETX
				ID	Master	Mode	Time Duration	
	0x02	0x89	0x04	Variable	0x01	Variable	Variable	0x03

\* ID range(Program): 0x01(1) ~ 0xFF(255)

\* Mode : Full White Pattern(0x01), White Bar Scan(0x02), Default(0x00)

\* Time Duration : 0x00 : No Display, 0x01: 5 Minute , 0x03: 15 Minute, 0x06: 30 Minute, 0x0C : 1 Hour...0xF0: 20 Hour)

B. Broadcast command

Value	STX	CMD	Length	Data			ETX
				ID	Mode	Time Duration	
	0x02	0x89	0x03	0x00	Variable	Variable	0x03

\* All PDP will do the same operation simultaneously. But, there will be no return communication. (One way command)

\* Mode : Full White Pattern(0x01), White Bar Scan(0x02), Default(0x00)

\* Time Duration : 0x00 : No Display, 0x01: 5 Minute , 0x03: 15 Minute, 0x06: 30 Minute, 0x0C : 1 Hour...0xF0: 20 Hour)

#### - Receive from MPDP

Value	STX	CMD	Length	Data		Check Sum	ETX
				ID	Master		
	0x02	0x89	0x02	Variable	Variable	Variable	0x03

\* ID range(Program): 0x01(1) ~ 0xFF(255)

\* Check Sum: Execute "Not" operation after adding all the values in "STX~Data" area.

### 3.4. Multi-Scale

- Command for expanding the screen of MPDP.
- It is available only on Power On (Operative) status.
- CMD: 0xDD (DVI), 0xDE(PC), 0XE2(VIDEO)
- Send to MPDP

A. Normal command

Value	STX	CMD	Length	Data				ETX
				ID	Master	XY	P	
	0x02	Variable	0x04	Variable	0x01	Variable	Variable	0x03

\* ID range (Program): 0x01(1) ~ 0xFF(255)

\* XY: The number of horizontal axis (X)/ the number of vertical axis(Y); upper 4 bits -X (Max:15), Lower 4bits - Y (Max: 15)

\* P: the location of expanded screen

B. Broadcast command

Value	STX	CMD	Length	Data				ETX
				ID	XY	S	X	
	0x02	Variable	0x04	0x00	Variable	Variable	Variable	0x03

\* ID: 0x00

\* XY: The number of MPDP sets in horizontal line(X), the number of MPDP sets in vertical line(Y)

The top 4bits - X (Max: 15), the bottom 4bits - Y (Max: 15)

1:1 screen ratio (Full screen) is "0x11"

\* S: The ID of MPDP to be expanded in top left position, 1:1 screen ratio (Full screen) is "0x00"

\* X: The number of all X axis line, 1:1 screen ratio (Full screen) is "0x01"

\* Make all PDP do the same operation. But, there will be no return communication. (One way command)

Broadcast command: e.g.) In case of 5x5 MPDP formation

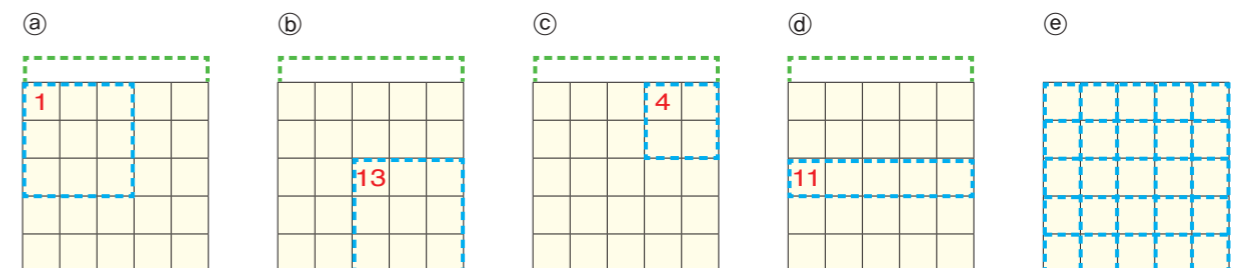

a	0x02(STX)	0xDD(CMD)	0x04(Length)	0x00(ID)	0x33(XY)	0x01(S)	0x05(X)	0x03(ETX)
b	0x02(STX)	0xDD(CMD)	0x04(Length)	0x00(ID)	0x33(XY)	0x0D(S)	0x05(X)	0x03(ETX)
c	0x02(STX)	0xDD(CMD)	0x04(Length)	0x00(ID)	0x22(XY)	0x04(S)	0x05(X)	0x03(ETX)
d	0x02(STX)	0xDD(CMD)	0x04(Length)	0x00(ID)	0x41(XY)	0x0B(S)	0x05(X)	0x03(ETX)
e	0x02(STX)	0xDD(CMD)	0x04(Length)	0x00(ID)	0x11(XY)	0x00(S)	0x01(X)	0x03(ETX)

- Receive from MPDP

Value	STX	CMD	Length	Data		Check Sum	ETX
				ID	Master		
	0x02	Variable	0x02	Variable	0x01	Variable	0x03

\* ID range (Program): 0x01(1) ~ 0xFF(255)

\* Check Sum: execute "Not" operation after adding all the values in "STX-Data" area.

### 3.5. Infomation

- Command for displaying the information on the screen (Input source and resolution by OSD)
- **CMD : 0x42**
- **It is available only on Power On (Operative) status.**
- **Send to MPDP**

A. Normal command

Value	STX	CMD	Length	Data		ETX
				ID	Master	
	0x02	0x42	0x02	Variable	0x01	0x03

\* ID range(Program): 0x01(1) ~ 0xFF(255)

B. Broadcast command

Value	STX	CMD	Length	Data: ID	ETX
	0x02	0x42	0x01	0x00	0x03

\* All PDP will do the same operation simultaneously. But, there will be no return communication. (One way command)

- Receive from MPDP

Value	STX	CMD	Length	Data		Check Sum	ETX
				ID	Master		
	0x02	0x40	0x02	Variable	0x01	Variable	0x03

\* ID range (Program): 0x01(1) ~ 0xFF(255)

\* Check Sum: execute "Not" operation after adding all the values in "STX-Data" area.

### 3.6. Input-Mode Change

- Command for changing input mode without screen scaling
- **It is available only on Power On (Operative) status.**
- **CMD: 0xDD(DVI), 0xDE(PC), 0XE2(Video)**
- **Send to MPDP**

A. Normal Command

Value	STX	CMD	Length	Data				ETX
				ID	Master	XY	X	
	0x02	Variable	0x04	Variable	0x01	0x11	0x01	0x03

\* ID range(Program): 0x01(1) ~ 0xFF(255)

B. Broadcast Command

Value	STX	CMD	Length	Data				ETX
				ID	XY	S	X	
	0x02	Variable	0x04	0x00	0x11	0x00	0x01	0x03

\* All PDP will do the same operation simultaneously. But, there will be no return communication. (One way command)

- Receive from MPDP

Value	STX	CMD	Length	Data		Check Sum	ETX
				ID	Master		
	0x02	Variable	0x02	Variable	0x01	Variable	0x03

\* ID range (Program): 0x01(1) ~ 0xFF(255)

\* Check Sum: execute "Not" operation after adding all the values in "STX-Data" area.

### 3.7. Global Offset

- Command for removing the image data in seam area (On) or displaying all the data on the screen (Off)
- **It is available only on Power On (Operative) status.**
- **CMD: 0x74(On), 0x73(Off)**
- **Send to MPDP**

A. Normal Command

Value	STX	CMD	Length	Data		ETX
				ID	Master	
	0x02	Variable	0x02	Variable	0x01	0x03

\* ID range(Program): 0x01(1) ~ 0xFF(255)

B. Broadcast Command

Value	STX	CMD	Length	Data: ID	ETX
	0x02	Variable	0x01	0x00	0x03

\* Make all PDP do the same operation. But, there will be no return communication. (One way command)

- Receive from MPDP

Value	STX	CMD	Length	Data		Check Sum	ETX
				ID	Master		
	0x02	Variable	0x02	Variable	0x01	Variable	0x03

\* ID range (Program): 0x01(1) ~ 0xFF(255)

\* Check Sum: execute "Not" operation after adding all the values in "STX-Data" area.

### 3.8. Auto-Power Mode

- Configuration for automatic power on by AC power connection.
- It is available only on Power On (Operative) status.
- **CMD: 0x62(On), 0x63(Off)**
- **Send to MPDP**

A. Normal Command

	STX	CMD	Length	Data		ETX
				ID	Master	
Value	0x02	Variable	0x02	Variable	0X01	0x03

\* ID range(Program): 0x01(1) ~ 0xFF(255)

B. Broadcast Command

	STX	CMD	Length	Data: ID	ETX
Value	0x02	Variable	0x01	0x00	0x03

\* All PDP will do the same operation simultaneously. But, there will be no return communication. (One way command)

- **Receive from MPDP**

	STX	CMD	Length	Data		Check Sum	ETX
				ID	Master		
Value	0x02	Variable	0x02	Variable	0X01	Variable	0x03

\* ID range (Program): 0x01(1) ~ 0xFF(255)

\* Check Sum: execute "Not" operation after adding all the values in "STX-Data" area..

### 3.9. DTV Over-Scan On/Off

- Users can select Over-scan when input is DTV resolution from DVI. It is only available with DVI mode.
- **CMD: 0xE4(On), 0xE5(Off)**
- It is usable only at Power on status.
- **Send to MPDP**

A. Normal Command

	STX	CMD	Length	Data		ETX
				ID	Master	
Value	0x02	Variable	0x02	Variable	0X01	0x03

\* ID range(Program): 0x01(1) ~ 0xFF(255)

B. Broadcast Command

	STX	CMD	Length	Data: ID	ETX
Value	0x02	Variable	0x01	0x00	0x03

\* Make all PDP do the same operation. But, there will be no return communication. (One way command)

- **Receive from MPDP**

	STX	CMD	Length	Data		Check Sum	ETX
				ID	Master		
Value	0x02	Variable	0x02	Variable	0X01	Variable	0x03

\* ID range (Program): 0x01(1) ~ 0xFF(255)

\* Check Sum: Execute "Not" operation after adding all the values in "STX-Data" area.

### 3.10. Over-Temperature Shut-down Control

- **Commands for automatic power off making MPDP set stand-by and OSD warning method, if IP board temperature is 95°C or higher.**

- **CMD**

\* 0x64(Over Temperature Shut-down Enable)

: In case IP board temperature is 95°C or higher, display warning signal "High Temperature" in red for 1 minute at the lower left corner of MPDP and power off automatically (Stand-by mode.)

\* 0x65(Over Temperature Shut-down Disable)

: In case IP board temperature is 95°C or higher, display warning signal "High Temperature" in red for 3 seconds at the lower left corner of MPDP and repeat the warning every 60 seconds. (No automatic power off)

- **It is available only on Power On (Operative) status.**

- **The initial configuration is "Over Temperature Shut-down Enable."**

- **Send to MPDP**

A. Normal Command

	STX	CMD	Length	Data		ETX
				ID	Master	
Value	0x02	Variable	0x02	Variable	0X01	0x03

\* ID range(Program): 0x01(1) ~ 0xFF(255)

B. Broadcast Command

	STX	CMD	Length	Data: ID	ETX
Value	0x02	Variable	0x01	0x00	0x03

\* Make all PDP do the same operation. But, there will be no return communication. (One way command)

- **Receive from MPDP**

	STX	CMD	Length	Data		Check Sum	ETX
				ID	Master		
Value	0x02	Variable	0x02	Variable	0x01	Variable	0x03

\* ID range(Program): 0x01(1) ~ 0xFF(255)

\* Check Sum: Add the sum from STX to Data and execute "Not" operation.

### 3.11. Test Pattern

- **Command for checking the operating status with internal patterns**
- **It is available only on Power On (Operative) status.**
- **CMD: 0x57 (Red), 0x58 (Green), 0x59 (Blue), 0x5A (White), 0x5B (Screen)**
- **Send to MPDP**

A. Normal Command

	STX	CMD	Length	Data		ETX
				ID	Master	
Value	0x02	Variable	0x02	Variable	0X01	0x03

\* ID range(Program): 0x01(1) ~ 0xFF(255)

B. Broadcast Command

	STX	CMD	Length	Data: ID	ETX
Value	0x02	Variable	0x01	0x00	0x03

\* Make all PDP do the same operation. But, there will be no return communication. (One way command)

- Receive from MPDP

Value	STX	CMD	Length	Data		Check Sum	ETX
				ID	Master		
	0x02	Variable	0x02	Variable	0X01	Variable	0x03

\* ID range (Program): 0x01(1) ~ 0xFF(255)

\* Check Sum: execute "Not" operation after adding all the values in "STX-Data" area.

### 3.12. Elapsed Time

- Command for informing the elapsed time of each PDP set. (Basic unit: hour)
- It is available only on Power On (Operative) status.
- CMD : 0x77 (Get), 0x7B (Initial)
- Send to MPDP

Value	STX	CMD	Length	Data		ETX
				ID	Master	
	0x02	Variable	0x02	Variable	0X01	0x03

\* ID range (Program): 0x01(1) ~ 0xFF(255)

\* It is not applicable as "Broad-cast" command

- Receive from MPDP

Value	STX	CMD	Length	Data			Check Sum	ETX
				ID	Master	Elapsed Time		
	0x02	Variable	0x08	Variable	0X01	...	Variable	0x03

Hundred thousands	ten thousands	thousands	hundreds	ten	one
Variable	Variable	Variable	Variable	Variable	Variable

\* ID range(Program): 0x01(1) ~ 0xFF(255)

\* Check Sum: Execute "Not" operation after adding all the values in "STX-Data" area.

\* Elapsed Time

- Hundred thousands, ten thousands, thousands, hundreds, tens, ones: 0(0x00)~9(0x09) range value.

### 3.13. IP Serial Number

- Command for assigning and identifying the serial numbers of each IP board. (8 digit)
- CMD: 0x75 (Get S/N), 0x76 (Set S/N)
- Send to MPDP

Value	STX	CMD	Length	Data		ETX
				ID	Master	
	0x02	Variable	0x02	Variable	0X01	0x03

\* ID range (Program): 0x01(1) ~ 0xFF(255)

\* "Get/Set IP Serial Number"(0x75/0x76) command is not applicable as "Broad-cast" command, because each PDP should have an unique serial number.

- Receive from MPDP

Value	STX	CMD	Length	Data			Check Sum	ETX
				ID	Master	S/N		
	0x02	Variable	0x0A	Variable	0x01	...	Variable	0x03

0	1st	2nd	3rd	4th	5th	6th	7th
Variable	Variable	Variable	Variable	Variable	Variable	Variable	Variable

\* ID range(Program): 0x01(1) ~ 0xFF(255)

\* Check Sum: Execute "Not" operation after adding all the values in "STX-Data" area.

\* Elapsed Time

- 0, 1st, 2nd, 3rd, 4th, 5th, 6th, 7th: 0(0x00)~9(0x09) range value

### 3.14. Get Current Status

- Command for obtain the current PDP (IP) information
- CMD: 0x87
- It is available only on Power On (Operative) status.
- Send to MPDP

Value	STX	CMD	Length	Data		ETX
				ID	Master	
	0x02	0x87	0x02	Variable	0X01	0x03

\* ID range (Program): 0x01(1) ~ 0xFF(255)

\* It cannot be used as "Broad-cast" command.

- Receive from MPDP

Value	STX	CMD	Length	Data			Check Sum	ETX
				ID	Master	Status		
	0x02	0x87	0x23	Variable	0X01	...	Variable	0x03

\* ID range(Program): 0x01(1) ~ 0xFF(255)

\* Check Sum: Execute "Not" operation after adding all the values in "STX-Data" area.

\* Status (32 byte)

No.	Data	Length	Explanation
1	PWR Status	1 byte	0: Power Off (Stand-by), 1: Power On (Working)
2	Input Source	1 byte	0x0C: PC, 0x0E: DVI, 0x0D: DTV, 0x07: DVD, 0x05: S-Video, 0x02: Video
3	Resolution	1 byte	The value of "Displayed Resolution at the time of detection"
4	Not Used		
5	Global Offset	1 byte	0: Global Offset Off, 1: Global Offset On
6	Color Temp.	1 byte	0: Normal mode, 1: Studio mode
7	Auto-Power Mode	1 byte	0: Auto-Power Off, 1: Auto-Power On
8	FAN Mode	1 byte	0: Auto, 1: Full
9	Temperature0	1 byte	0(0x00): 0°C~ 127(0x7F): 127°C / 128(0x80): -1°C ~ 254(0xFE): -127°C 0xFF: Temp. Sensor Error
10	Temperature1	1 byte	0(0x00): 0°C ~ 127(0x7F): 127°C / 128(0x80): -1°C ~ 254(0xFE): -127°C 0xFF: Temp. Sensor Error
11	FAN Status	1 byte	0x30: Good, 0x31: Error
12~18	F/W Version	7 byte	Year: 2 byte, Month: 2byte, Day: 2byte, Rev.(0~9):1byte Ex) December 29th, 2012 Rev. 2 → 0x01 0x02 0x01 0x02 0x02 0x09 0x02
19	Not Used		
20~27	S/N	8 byte	123456 → 0x00 0x00 0x01 0x02 0x03 0x04 0x05 0x06 1 → 0x00 0x00 0x00 0x00 0x00 0x00 0x00 0x01

28~33	Elapsed Time	6 byte	54321 → 0x00 0x05 0x04 0x03 0x02 0x01 10 → 0x00 0x00 0x00 0x00 0x01 0x00
34	Afterimage Mitigation Status(Mode)	1 byte	Default(No Display) : 0x00 Full White : 0x01 White Bar Scan : 0x02
35	Afterimage Mitigation Time(Time Duration)	1 byte	Ex)0x01: 5 Minute , 0x03: 15 Minute, 0x06: 30 Minute, 0x0C :1 Hour... 0xF0: 20 Hour

< Displayed Resolution at the time of detection (It is different from the supporting Resolution) >

Resolution	Value	Resolution	Value	Resolution	Value
640x480x60	0(0x00)	720Px50	29(0x1D)	1360x768x60	25(0x19)
<b>640x480x85</b>	<b>1(0x01)</b>	576Px50	30(0x1E)	<b>640x350x85</b>	<b>46(0x2E)</b>
<b>800x600x56</b>	<b>2(0x02)</b>	480Px60	31(0x1F)	<b>640x480x75</b>	<b>47(0x2F)</b>
800x600x60	3(0x03)	1920x1080ix60	32(0x20)	<b>640x480x72</b>	<b>48(0x30)</b>
<b>800x600x75</b>	<b>4(0x04)</b>	1920x1080ix50	33(0x21)	<b>1152x864x75</b>	<b>49(0x31)</b>
<b>800x600x85</b>	<b>5(0x05)</b>	1280x720Px60	34(0x22)	1280x720x60	50(0x32)
853x480x60	6(0x06)	1280x720Px50	35(0x23)	<b>1280x768x75</b>	<b>51(0x33)</b>
1024x768x60	7(0x07)	PAL	36(0x24)	<b>1280x1024x75</b>	<b>52(0x34)</b>
<b>1024x768x70</b>	<b>8(0x08)</b>	SECAM	37(0x25)	1366x768x50	53(0x35)
<b>1024x768x75</b>	<b>9(0x09)</b>	PALP	38(0x26)	1400x1050x50	54(0x36)
<b>1024x768x85</b>	<b>10(0x0A)</b>	NTSC	39(0x27)	1440x900x60	55(0x37)
1280x768x60	11(0x0B)	NTSCP	40(0x28)	576ix50	56(0x38)
1280x960x60	12(0x0C)	Unknown	42(0x2A)	480ix60	57(0x39)
1280x1024x60	13(0x0D)	No-Signal	43(0x2B)	1080px60	58(0x3A)
1366x768x60	14(0x0E)	853x480x50	18(0x12)	1080px50	59(0x3B)
1600x1200x60	15(0x0F)	1280x1024x50	19(0x13)	1920x1080px60	60(0x3C)
1400x1050x60	16(0x10)	1360x768x50	20(0x14)	1920x1080px50	61(0x3D)
1706x960x60	17(0x11)	1600x900x50	21(0x15)	1024x576x50	62(0x3E)
1080ix60	26(0x1A)	1600x900x60	22(0x16)	1024x576x60	63(0x3F)
1080ix50	27(0x1B)	1600x1200x50	23(0x17)		
720Px60	28(0x1C)	800x600x50	24(0x18)		

※ The resolutions written in red or italic letters can be detected, but they are not supporting resolutions.

### 3.15. Graphic User Mode Control

- Command for controlling Brightness, Contrast, Sharpness
- CMD: 0x8A (Brightness), 0x8B (Contrast), 0x8C (Sharpness)
- It is available only on Power On (Operative) status.
- The adjusted value is not applied during Stand-by or No-signal status.
- Send to MPDP

A. Normal Command

Value	STX	CMD	Length	Data			ETX
				ID	Master	Control	
Value	0x02	Variable	0x03	Variable	0X01	Variable	0x03

\* ID range(Program): 0x01(1) ~ 0xFF(255)

\* Control: Brightness ("0" ~ "100"), Contrast ("0" ~ "100"), Sharpness ("0" ~ "28")

B. Broadcast Command

Value	STX	CMD	Length	Data		ETX
				ID	Value	
Value	0x02	Variable	0x02	0x00	Variable	0x03

\* Make all PDP do the same operation. But, there will be no return communication. (One way command)

\* Control: Brightness ("0" ~ "100"), Contrast ("0" ~ "100"), Sharpness ("0" ~ "28")

- Receive from MPDP

Value	STX	CMD	Length	Data		Check Sum	ETX
				ID	Master		
Value	0x02	Variable	0x02	Variable	0X01	Variable	0x03

\* ID range (Program): 0x01(1) ~ 0xFF(255)

\* Check Sum: Execute "Not" operation after adding all the values in "STX-Data" area.

### 3.16. Color Temperature

- Studio mode is 3600 (Default: Normal Mode).
- Normal mode is applicable for general purpose and Studio mode is designed for broadcasting purpose.
- It is available only on Power On (Operative) status.
- CMD: 0xB3 (Normal), 0xB4 (Studio: broadcasting purpose)
- Send to MPDP

A. Normal Command

Value	STX	CMD	Length	Data		ETX
				ID	Master	
Value	0x02	Variable	0x02	Variable	0X01	0x03

\* ID range(Program): 0x01(1) ~ 0xFF(255)

B. Broadcast Command

Value	STX	CMD	Length	Data: ID	ETX
Value	0x02	Variable	0x01	0X00	0x03

\* Make all PDP do the same operation. But, there will be no return communication. (One way command)

- Receive from MPDP

Value	STX	CMD	Length	Data		Check Sum	ETX
				ID	Master		
Value	0x02	Variable	0x02	Variable	0X01	Variable	0x03

\* ID range (Program): 0x01(1) ~ 0xFF(255)

\* Check Sum: execute "Not" operation after adding all the values in "STX-Data" area.

### 3.17. Tracking Mode

- A command for adjusting alignment manually or automatically or loading the predetermined values at PC RGB mode only.
- CMD: 0x4A (Auto-tracking), 0x4B (Get Tracking Values), 0x4C (Frequency- tracking), 0x4D (Phase-tracking), 0x4E (Line-Start tracking), 0x4F (Pixel-Start tracking)
- It is available only on Power On (Operative) status.
- Send to MPDP



A. Normal Command

	STX	CMD	Length	Data		ETX
				ID	Master	
Value	0x02	Variable	0x02	Variable	0X01	0x03

B. Broad-Cast Command

	STX	CMD	Length	Data: ID	ETX
Value	0x02	Variable	0x01	0x00	0x03

C. Frequency/Phase/Line-Start/Pixel-Start -tracking (Normal Command): Adjusting PC (RGB) screen manually.

	STX	CMD	Length	Data			ETX
				ID	Master	Tracking Value	
Value	0x02	Variable	0x03	Variable	0X01	Variable	0x03

D. Frequency/Phase/Line-Start/Pixel-Start -tracking (Broad-Cast Command): Adjusting PC (RGB) screen manually.

	STX	CMD Value	Length	Data		ETX
				ID	Tracking Value	
Value	0x02	Variable	0x02	0x00	Variable	0x03

\* ID range (Program): 0x01(1) ~ 0xFF(255)

\* Broad-cast: All PDP sets will execute the same command, when the ID is 0x00. No response (One way command)

\* "Get Tracking Value" command cannot be used for "Broad-cast" command.

- Frequency value range: 77(0x4D) ~ 177(0xB1) / Real Value(-50 ~ +50) / Real Value + 127(0x7F)
- Phase value range: 127(0x7F) ~ 190(0xBE) / Real Value(0 ~ +63) / Real Value + 127(0x7F)
- Line Start value range: 104(0x68) ~ 137(0x89) / Real Value(-23 ~ +10) / Real Value + 127(0x7F)
- Pixel Start value range: 77(0x4D) ~ 167(0xA7) / Real Value(-50 ~ +40) / Real Value + 127(0x7F)

- Receive from MPDP

A. Auto-tracking, Frequency/Phase/Line-Start/Pixel-Start-tracking

	STX	CMD	Length	Data		Check Sum	ETX
				ID	Master		
Value	0x02	Variable	0x02	Variable	0X01	Variable	0x03

B. Get Tracking Values

	STX	CMD	Length	Data			Check Sum	ETX
				ID	Master	Tracking Value		
Value	0x02	Variable	0x06	Variable	0X01	...	Variable	0x03

Frequency	Phase	LineStart	PixelStart
Variable	Variable	Variable	Variable

\* ID range(Program): 0x01(1) ~ 0xFF(255)

\* Tracking Value

- Frequency value range : 77(0x4D) ~ 177(0xB1) / Real Value(-50 ~ +50) / Real Value + 127(0x7F)
- Phase value range : 127(0x7F) ~ 190(0xBE) / Real Value(0 ~ +63) / Real Value + 127(0x7F)
- Line Start value range : 104(0x68) ~ 137(0x89) / Real Value(-23 ~ +10) / Real Value + 127(0x7F)
- Pixel Start value range : 77(0x4D) ~ 167(0xA7) / Real Value(-50 ~ +40) / Real Value + 127(0x7F)

\* Check Sum: execute "Not" operation after adding all the values in "STX-Data" area.

### 3.18. Sync Correction

- It is the command for reducing the flashing effect.

#### 1) Sync Correction Mode

- User can select or switch the Sync Control mode; "Auto" or "Manual."
- CMD: 0xC9
- It is functioning only for Power On status.
- Send to MPDP

A. Normal command

	STX	CMD	Length	Data			ETX
				ID	Master	Mode	
Value	0x02	0xC9	0x03	Variable	0x01	Variable	0x03

\* ID range (Program): 0x01(1) ~ 0xFF(255)

\* Mode: Manual (0x00), Auto (0x01)

B. Broadcast command

	STX	CMD	Length	Data		ETX
				ID	Mode	
Value	0x02	0xC9	0x02	0x00	Variable	0x03

\* Execute the same command for all PDP sets. No response will be made. (One-way command)

\* Mode : Manual(0x00), Auto (0x01)

- Receive from MPDP

	STX	CMD	Length	Data		Check Sum	ETX
				ID	Master		
Value	0x02	0x89	0x02	Variable	0x01	Variable	0x03

\* ID range (Program) : 0x01(1) ~ 0xFF(255)

\* Check Sum : Add the values from STX to Data and execute the "NOT" operation.

#### 2) Sync Correction Time Write

- Sync Correction Time for MPDP can be configured. It is only available for Manual mode.
- CMD : 0x6A
- Send to MPDP

A. Normal command

	STX	CMD	Length	Data			ETX
				ID	Master	Control Data	
Value	0x02	0x6A	0x09	Variable	0X01	Variable	0x03

BIT Mode	Read/Write Mode	Address	TimeData(4 Bytes)
0x04	0x00	0xA2	Variable

\* ID range (Program) : 0x01(1)~ 0xFF(255)

\* Control Data

-Time Data : 0x00000000 ~ 0x000000FF (0~255, 4Bytes)

B. Broadcast command

	STX	CMD	Length	Data		ETX
				ID	Control Data	
Value	0x02	0x6A	0x08	0x00	Variable	0x03

BIT Mode	Read/Write Mode	Address	TimeData(4 Bytes)
0x04	0x00	0xA2	Variable

\* Execute the same command for all PDP sets. No response will be made. (One-way command)  
 \* Control Data  
 -Time Data : 0x00000000 ~ 0x000000FF (0~255, 4Bytes)

- Receive from MPDP

	STX	CMD	Length	Data		Check Sum	ETX
				ID	Master		
Value	0x02	0x6A	0x02	Variable	0x01	Variable	0x03

\* ID range (Program) : 0x01(1) ~ 0xFF(255)  
 \* Check Sum : Add the values from STX to Data and execute the "NOT" operation

### 3) Sync Correction Read

- The information for Sync Control related configuration and changes can be read.

- CMD : 0x6A

- Send to MPDP

A. Normal command

	STX	CMD	Length	Data			ETX
				ID	Master	Control Data	
Value	0x02	0x6A	0x05	Variable	0x01	Variable	0x03

BIT Mode	Read/Write Mode	Address
0x04	0x01	0xA2

\* ID range (Program) : 0x01(1)~ 0xFF(255)  
 \* It is not available for Broadcast command.

- Receive from MPDP

	STX	CMD	Length	Data			Check Sum	ETX
				ID	Master	Control		
Value	0x02	0x6A	0x0A	Variable	Variable	Variable	Variable	0x03

BIT Mode	Read/WriteMode	Address	Time Data(4 Bytes)	Manual/ Auto Mode
0x04	0x01	0xA2	Variable	Variable

\* ID range (Program) : 0x01(1) ~ 0xFF(255)  
 \*Slave / Master : Master(0x01)  
 \*Control  
 - Time Data : 0x00000000 ~ 0x000000FF (0~255, 4Bytes), In case of Auto Mode, the response will be 0x00000000(0).  
 - Manual /Auto Mode : 0(0x00) for Manual , 1(0x01) for Auto  
 \*Check Sum : Add the values from STX to Data and execute the "NOT" operation

### 3.19. White Balance Control

- Command for adjusting Gain R/G/B and Offset R/G/B for White balance
- CMD: 0xAC (Gain R), 0xAD (Gain G), 0xAE (Gain B), 0xB0 (Offset R), 0xB1 (Offset G), 0xB2 (Offset B)
- The adjusted value is not applied during Stand-by or No-signal status. MPDP must be operating status and there must be the input signal of each mode.
- To apply the same configuration to all MPDP sets, the "ID" area value can be set as "0x00." However, considering differences between sets, individual adjustment for white balance is recommended.

- Send to MPDP

A. Normal Command

	STX	CMD	Length	Data			ETX
				ID	Master	Control	
Value	0x02	Variable	0x03	Variable	0x01	Variable	0x03

\* ID range(Program): 0x01(1) ~ 0xFF(255)  
 \* Control: "0 (0x00)" ~ "255 (0xFF)"

- Receive from MPDP

	STX	CMD	Length	Data		Check Sum	ETX
				ID	Master		
Value	0x02	Variable	0x02	Variable	0x01	Variable	0x03

\* ID range (Program): 0x01(1) ~ 0xFF(255)  
 \* Check Sum: Execute "Not" operation after adding all the values in "STX--Data" area.

### 3.20. Firmware Default Set (Picture Control Data)

- Initialize the PDP set. All the settings will be returned to the initial condition prior to the adjustment in the factory. Pre-programmed value will be applied.
- CMD : 0x81
- It is available only on Power On (Operative) status.
- Since previous Picture Control Data will be lost with this command. High caution is required.
- Send to MPDP

	STX	CMD	Length	Data		ETX
				ID	Master	
Value	0x02	0x81	0x02	Variable	0x01	0x03

\* ID range(Program): 0x01(1) ~ 0xFF(255)  
 \* It is not applicable as "Broad-cast" command.

- Receive from MPDP

	STX	CMD	Length	Data		Check Sum	ETX
				ID	Master		
Value	0x02	0x81	0x02	Variable	0x01	Variable	0x03

\* ID range(Program): 0x01(1) ~ 0xFF(255)  
 \* Check Sum: Execute "Not" operation after adding all the values in "STX--Data" area.

### 3.21. Get Picture Control Data

- Command for acquiring the current Picture Control Data(User Mode, White Balance, Graphic, Video)
- CMD: 0x88
- It is available only on Power On (Operative) status.
- The values based on current Color Temp. (Normal Mode / Studio Mode) will be displayed.
- Send to MPDP

	STX	CMD	Length	Data		ETX
				ID	Master	
Value	0x02	0x88	0x02	Variable	0x01	0x03

\* ID range(Program): 0x01(1) ~ 0xFF(255)

\* It is not applicable as "Broad-cast" command.

- Receive from MPDP

	STX	CMD	Length	Data			Check Sum	ETX
				ID	Master	Control		
Value	0x02	0x88	0x34	Variable	0x01	...	Variable	0x03

\* ID range(Program): 0x01(1) ~ 0xFF(255)

\* Control (50 byte)

No.	Data	Length	Explanation
1	User Mode – Brightness	1 byte	Range: 0(0x00) ~ 100(0x64)
2	User Mode – Contrast	1 byte	Range: 0(0x00) ~ 100(0x64)
3	User Mode – Sharpness	1 byte	Range: 0(0x00) ~ 28(0x1C)
4	Not Used		
5	Not Used		
6	White Balance – Gain R	1 byte	Range: 0(0x00) ~ 255(0xFF)
7	White Balance – Gain G	1 byte	Range: 0(0x00) ~ 255(0xFF)
8	White Balance – Gain B	1 byte	Range: 0(0x00) ~ 255(0xFF)
9	White Balance – Offset R	1 byte	Range: 0(0x00) ~ 255(0xFF)
10	White Balance – Offset G	1 byte	Range: 0(0x00) ~ 255(0xFF)
11	White Balance – Offset B	1 byte	Range: 0(0x00) ~ 255(0xFF)
12, 13	RGB - Gain R	2byte	Range : 0(0x000) ~ 1023(0X3FF)
14, 15	RGB - Gain G	2byte	Range : 0(0x000) ~ 1023(0X3FF)
16, 17	RGB - Gain B	2byte	Range : 0(0x000) ~ 1023(0X3FF)
18, 19	RGB - Offset R	2byte	Range : 0(0x000) ~ 1023(0X3FF)
20, 21	RGB - Offset G	2byte	Range : 0(0x000) ~ 1023(0X3FF)
22, 23	RGB - Offset B	2byte	Range : 0(0x000) ~ 1023(0X3FF)
24 ~ 47	Not Used	24byte	
48	Video Brightness	1byte	Range : 0(0x00) ~ 255(0xFF)
49	Video Contrast	1byte	Range : 0(0x00) ~ 255(0xFF)
50	Video Color	1byte	Range : 0(0x00) ~ 255(0xFF)

### 3.22. Auto Calibration

- Command for synchronizing the ADC Gain and Offset for 16-Gray input. It is available only for PC.
- It is available only on Power On (Operative) status.
- CMD : 0x80
- Send to MPDP

A. Normal Command

	STX	CMD	Length	Data		ETX
				ID	Master	
Value	0x02	0x80	0x02	Variable	0x01	0x03

B. Broadcast Command

	STX	CMD	Length	Data: ID	ETX
Value	0x02	0x80	0x01	0x00	0x03

\* ID range (Program): 0x01(1) ~ 0xFF(255)

\* Broadcast: All PDP sets will execute the same command, when the ID is 0x00. No response (One way command)

- Receive From MPDP

	STX	CMD	Length	Data		Check Sum	ETX
				ID	Master		
Value	0x02	0x80	0x02	Variable	0x01	Variable	0x03

### 3.23. Factory Data (Picture Control Data)

- Command for loading the Picture Control data (User Mode / White Balance / RGB Data / VIDEO Data) adjusted in the factory.
- CMD : 0x82(Save), 0x83(Load))
- It is usable only at Power on Operative
- It shows the value based on current Color Temp. (Normal Mode / Studio Mode.)
- Data can be checked with "Get Picture Control Data" after executing the command
- Send to MPDP

	STX	CMD	Length	Data		ETX
				ID	Master	
Value	0x02	Variable	0x02	Variable	0x01	0x03

\* ID range(Program): 0x01(1) ~ 0xFF(255)

- Receive from MPDP

	STX	CMD	Length	Data		Check Sum	ETX
				ID	Master		
Value	0x02	Variable	0x02	Variable	0x01	Variable	0x03

\* ID range(Program): 0x01(1) ~ 0xFF(255)

\* Check Sum: Execute "Not" operation after adding all the values in "STX--Data" area.

### 3.24. Get Temperature Status

- Command for acquiring temperature information.
- CMD : 0x7F
- It is usable only at Power on status.
- Send to MPDP

Value	STX	CMD	Length	Data		ETX
				ID	Master	
	0x02	0x7F	0x02	Variable	0x01	0x03

\* ID range(Program): 0x01(1) ~ 0xFF(255)

\* It is not applicable as "Broad-cast" command.

- Receive from MPDP

Value	STX	CMD	Length	Data			Check Sum	ETX
				ID	Master	Temperature Values		
	0x02	0xF7	0x04	Variable	0x01	...	Variable	0x03

Temp.0	Temp.1
Variable	Variable

\* Temperature Values (Temp.0, Temp.1)

- 0(0x00): 0°C ~ 127(0x7F): 127°C

- 128(0x80): -1°C ~ 254(0xFE): -127°C

- 0xFF: Temp. Sensor Error

\* Check Sum: Execute "Not" operation after adding all the values in "STX-Data" area.

### ※ Attachment : ASCII to HEX Conversion Table

ASCII	HEX	ASCII	HEX	ASCII	HEX	ASCII	HEX	ASCII	HEX	ASCII	HEX	ASCII	HEX
STX	02	*	2A	9	39	H	48	W	57	f	66	u	75
ETX	03	+	2B	:	3A	I	49	X	58	g	67	v	76
Esc	1B	,	2C	;	3B	J	4A	Y	59	h	68	w	77
CR	0D	-	2D	<	3C	K	4B	Z	5A	i	69	x	78
LF	0A	.	2E	=	3D	L	4C	[	5B	j	6A	y	79
Space	20	/	2F	>	3E	M	4D	\	5C	k	6B	z	7A
!	21	0	30	?	3F	N	4E	]	5D	l	6C	{	7B
"	22	1	31	@	40	O	4F	^	5E	m	6D		7C
#	23	2	32	A	41	P	50	-	5F	n	6E	}	7D
\$	24	3	33	B	42	Q	51	`	60	o	6F	~	7E
%	25	4	34	C	43	R	52	a	61	p	70	DEL	7F
&	26	5	35	D	44	S	53	b	62	q	71		
'	27	6	36	E	45	T	54	c	63	r	72		
(	28	7	37	F	46	U	55	d	64	s	73		
)	29	8	38	G	47	V	56	e	65	t	74		

## 8. Other tips

### 8.1. Before calling for service

- Before calling for any repair, check the following and then refer to a near A/S center.

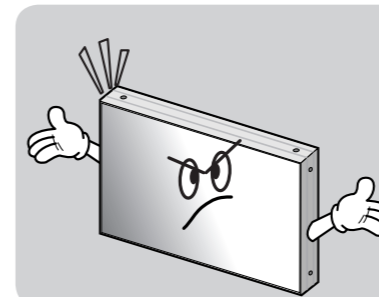

#### ▶ "Tick" sound from the main body.

- If there is no problem with the screen or sound, the "tick" sound is likely to result from the cabinet lightly shrinking with the change of room temperature. The sound does not affect product's performance.

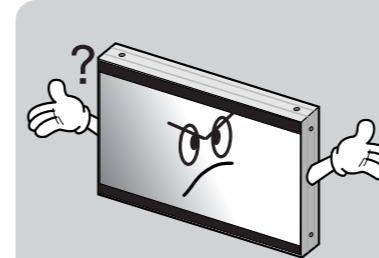

#### ▶ No image at upper and lower part of the screen.

- As for a screen which is over 16:9 in width (such as cinema-sized one), no image may be displayed at upper and bottom part of the screen.

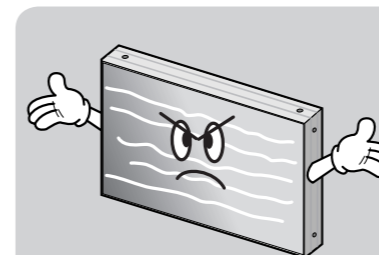

#### ▶ Speckles or white lines on the screen

- Check whether the problem is caused by vehicle, streetcar, high-voltage cable or neon sign, which emitting interference wave or electromagnetic induction. Avoid any interfering object.

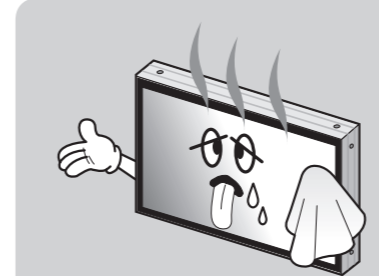

#### ▶ Screen or PDP Set is hot

- PDP sets or screen can be hot, because basic principle of PDP driving is Plasma discharge between electrodes.
- It is not a defect or a malfunction of the product, you may continue to use the product.

### 8.2. About Plasma display panel

- The followings are phenomena caused by characteristics of the plasma display panel.
- Since it is not a fault, you may continue to use the product.

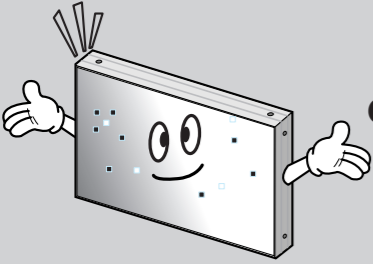

**Caution** ▶ **Black or twinkling spots on the screen**

- Although the plasma display panel is manufactured with high-precision technology, there may exist black or twinkling spots on the screen. Since it is not a fault, you may continue to use the product.

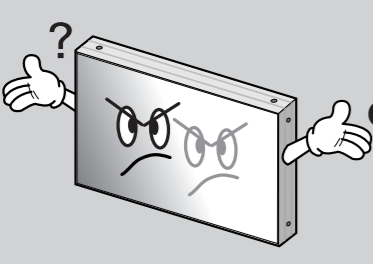

**Caution** ▶ **Burn-In effect**

- Displaying static images such as still video frames or computer screen images for an extended period of time may cause burn-in effect. The burn-in effect may be gradually reduced by displaying full white pattern.
- However, please always be careful in using static images on this product, because such burn-in effect may cause permanent damages in some cases.

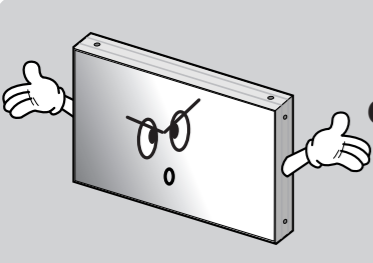

**Caution** ▶ **Noise from the inside**

- When you turn on the product slight buzzing sound may be heard from the rear of display panel. Since it is not a fault, you may continue to use the product.

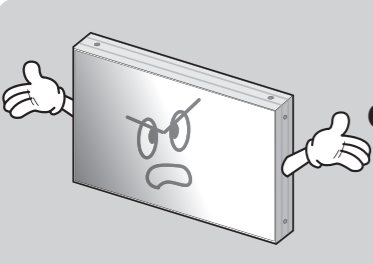

**Caution** ▶ **Screen decolorization**

- Optical film that is attached on the panel can be slightly decolorized after long time of use. The degree of decolorization may vary depending on display contents and conditions. It is due to the characteristics of the film, but it is not a defect. (It is caused by chemical characteristics of the film.)

### 9. Applicable DVI signals

- When you select PC for input source, it does not support DTV signal.

Resolution	V-Freq. (Hz)	H-Freq. (KHz)	Remarks
640 x 480	60	31.46	VESA DMT
800 x 600	50	30.99	VESA CVT
800 x 600	60	37.88	VESA DMT
853 x 480	50	31.50	-
853 x 480	60	31.50	VESA DMT
1024 x 768	60	48.36	
1280 x 768	60	47.69	VESA CVT
1280 x 960	60	60.00	VESA DMT
1280 x 1024	50	52.67	VESA CVT
1280 x 1024	60	63.97	VESA DMT
1360 x 768	50	39.56	VESA CVT
1360 x 768	60	47.71	VESA DMT
1366 x 768	50	48.79	-
1366 x 768	60	48.77	-
1400 x 1050	60	65.317	VESA CVT
1600 x 900	50	46.39	VESA CVT
1600 x 900	60	55.99	VESA CVT
1600 x 1200	50	61.79	VESA CVT
1600 x 1200	60	75.00	
1706 x 960	60	59.57	VESA DMT

- DTV signals

Resolution	Pixel Clock(MHz)	H-Freq. (KHz)	V-Freq. (Hz)
480p	27.000	31.467	60.00
576p	27.000	31.250	50.00
720p	74.250	45.000	60.00
720p	74.250	37.500	50.00
1080i	74.250	33.750	60.00
1080i	74.250	28.125	50.00
1080p	148.500	67.500	60.00
1080p	148.500	56.250	50.00

## 10. Specification

Model Name		OPM-4260	
Power supply		100 ~ 240V AC. 50/60Hz	
Power consumption	Max	330W	
	Average (Typical)	210W	* Based on IEC 62087 Ed.2 measurement method.(On Mode)
Plasma display panel		106cm (42), 16:9 Aspect Ratio	
Peak Brightness		1,700 cd/m <sup>2</sup> (Without film)	
Front filter		AG(Anti-Glare)	
Number of pixels		853(H) X 480(V)	
Seam gap (Active to active area)		1.9mm	
Environmental condition	Temperature	0°C~ 35°C	
	Humidity	20% ~ 70%	
Input /output Terminal		Input	Output
DVI (HDCP Available)		DVI-D 24pin	DVI-D 24pin
PC		D-Sub 15pin (female)	D-Sub 15pin (female)
Video		BNC 1pin	BNC 1pin
Serial		RS-232C D-sub 9pin(female)	RS-232C D-sub 9pin(male)
Ethernet		RJ45	
Service		RJ11	
External dimension 923.4mm[W] X 520.7mm[H] X73mm[D]			
Weight		21.7kg (±1kg)	

※Product design and specification can be changed for quality improvement without prior notice.

Model Name		OPM-4260R	
Power supply		100 ~ 240V AC. 50/60Hz	
Power consumption	Max	330W	
	Average (Typical)	210W	* Based on IEC 62087 Ed.2 measurement method.(On Mode)
Plasma display panel		106cm (42), 16:9 Aspect Ratio	
Peak Brightness		1,700 cd/m <sup>2</sup> (Without film)	
Front filter		AG(Anti-Glare)	
Number of pixels		853(H) X 480(V)	
Seam gap (Active to active area)		3.8mm	
Environmental condition	Temperature	0°C~ 35°C	
	Humidity	20% ~ 70%	
Input /output Terminal		Input	Output
DVI (HDCP Available)		DVI-D 24pin	DVI-D 24pin
PC		D-Sub 15pin (female)	D-Sub 15pin (female)
Video		BNC 1pin	BNC 1pin
Serial		RS-232C D-sub 9pin(female)	RS-232C D-sub 9pin(male)
Ethernet		RJ45	
Service		RJ11	
External dimension 925.4mm[W] X 522.7mm[H] X74.5mm[D]			
Weight		21.7kg (±1kg)	

※Product design and specification can be changed for quality improvement without prior notice.

## 11. Option Specification

### 11.1. DVI Converter

Product Name	Specification	
DVI Converter (ODC-10000)	Power supply	100 ~ 250V AC, 50/60Hz
	Power consumption	40W (MAX)
	Size	405mm(W) X 250mm(D) X 60mm(H)
	Environmental Condition	0°C~ 40°C, 20 ~80% RH
	Weight	3Kg

### Input/Output Specification

	Terminal Name	Terminal Specification	
Video Input Singal	Composite Video	BNC 1Pin	NTSC, PAL, SECAM
	S-Video	DIN 4Pin	NTSC, PAL, SECAM
	Component Video	BNC 3Pin	480i, 576i, 480p, 576p, 720p, 1080i, 1080p
	Analog RGB	D-Sub 15Pin	VGA, SVGA, WVGA, XGA, SXGA, WXGA, UXGA Horizontal Freq. : 15.5KHz ~ 75KHz Vertical Freq. : 50/60Hz
	DVI / HDMI	DVI-D 24Pin /HDMI 29Pin	480p, 576p, 720p, 1080i, 1080p VGA, SVGA, WVGA, XGA, SXGA, WXGA, UXGA Horizontal Freq. : 15.5KHz ~ 75KHz Vertical Freq. : 50/60Hz
	SDI	BNC 1Pin	SMPTE 259M-C, SMPTE 292M, SMPTE 424M, SMPTE 425 (Level A & B)
Video Output Signal	DVI	DVI-D 24Pin	640X480-60/85, 800X600-50/60/85, 853X480-50/60, 1027X768-60/85, 1280X1024-50/60, 1600X900-50/60, 1600X1200-50/60, 1706X960-60
Control Method	RS-232C	D-Sub 9Pin (Female)	Baud Rate : 115200 Max ±15V
	Ethernet	RJ-45	TCP/IP
	Key Pad		Input Souce Select Hot Key, Output Resolution Select Hot Key, Navigation Key(OSD), Control Channel Select, Communication Method Select.
Display	C-PDP	2X16	Input Souce, Output Resolution Display

※ Specification can be changed without prior notice to improve product quality.  
 ※ Ethernet communication is available when it is used with New MFC.

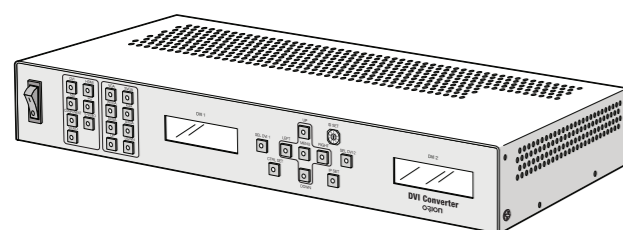

### 11.2. New MFC

Product Name	Specification	
Remote Controller	Name	MPDP REMOTE CONTROL
	Power	1.5V Battery(AAA) 2EA
	Size	55(W) x 190(L) x 25(H) mm
	Environmental Condition	-10°C ~ 40°C
	Weight	130g
NEW MFC	Voltage	+5~9V(DC), 1.25W (MAX)
	Power Consumption	250mA(Max, +5~9V)
	Size	58(W) x 216(L) x 46(H) mm
	Environmental Condition	0°C ~ 40°C, 20 ~80% RH
Adapter	Size	35(W) x 80(L) x 86(H) mm
	Input	90~264V(47~63Hz)
	Output	5V, 2000mA
	Output Jack	2.1φ(Internal diameter):Vcc, 5.5φ(External diameter):GND

### Input/Output Specification

NEW MFC	Terminal Name	Terminal Specification	
Control Input	RS-232C	D-Sub 9Pin (Female)	Baud Rate : 115200
	Ethernet	RJ-45	TCP/IP
	USB	Type B	USB2.0
	IR		Max 15m, left/right 45°(standard : 3m)
	Key Button		Control Mode Select (IR / Ethernet / RS-232C / USB)
Control Output	RS-232C (4ea)	D-Sub 9Pin (Male)	Baud Rate : 115200 Max ±15V
MPDP ID Setting	7-Segment LED	1~99	MPDP Horizontal Number, Vertical Number

- Minimum interval between button input: 0.6 second  
 ※ Specification can be changed without prior notice to improve product quality.

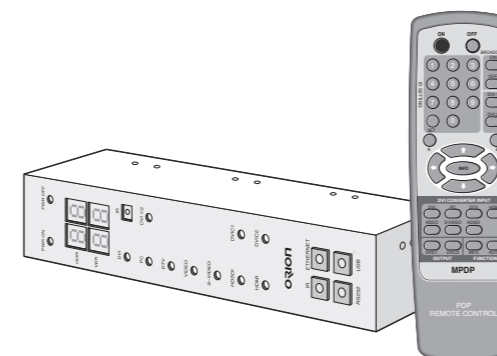

MEMO

MEMO